

VESTAPUMP

M a k e s l i f e c o m f o r t a b l e

PRODUCT CATALOGUE

www.vestapump.com

VPO5 PB SERIES PLASTIC BODY PUMP

VESTA POMP
Makes life comfortable



APPLICATION AREAS

- WASTE WATER TREATMENT
- TEXTILE
- PACKAGING
- CHEMICAL INDUSTRY
- AUTOMOTIVE
- FOOD INDUSTRY
- PAINT INDUSTRY
- MINING - ENERGY
- MARINE
- MACHINE-AUTOMATION

ADVANTAGES

- 1) Solid particles may pass through the pump.
- 2) Maintenance cost is low.
- 3) Liquid flow rate can also be adjusted when the air inlet pressure of the pump is adjusted.
- 4) The pump's air valve and pilot valve repair kits can be repaired without disassembling the pump.
- 5) It has the feature of working dry.
- 6) The suction depth of this pump is 6 m.

PUMP TECHNICAL SPECIFICATIONS

- Max. Capacity** : 55 l/min
- Fluid Inled-Outlet** : 3/4"
- Max. Fluid Discharge** : 7 bar
- Body Material** : PB (Glass fiber added polypropylene)
- Air Inlet Size** : 1/4"
- Solid Particle Size** : 3 mm
- Dry Suction Depth** : 6 m
- Max Air Pressure** : 7 bar
- Diaphragm Options** : Santoprene, Neoprene, Buna-N, EPDM, Teflon, Viton
- Ball Options** : Santoprene, Neoprene, Buna-N, EPDM, Teflon, Viton
- Ball Seat Options** : Santoprene, Neoprene, Buna-N, EPDM, Teflon, Viton

DIAPHRAGM PUMPS PERFORMANCE CURVES

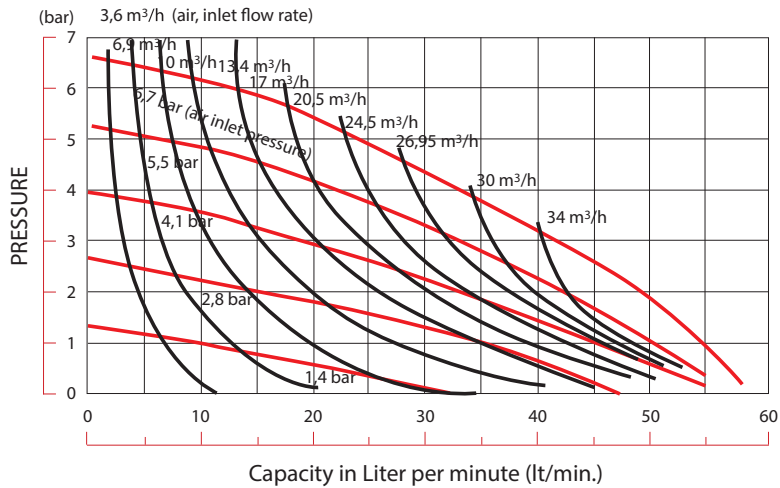

PUMP EXTERNAL DIMENSIONS

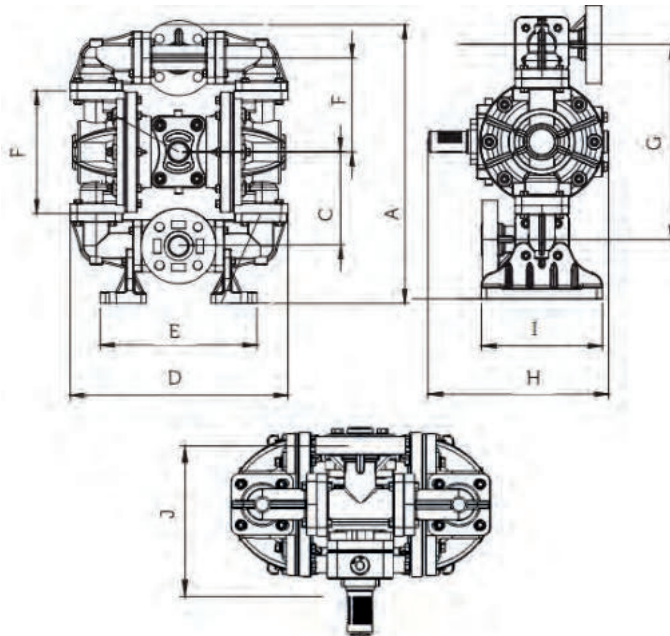

A	B	C	D	E	F	G	H	I	J
340	112	112	262	188	147	225	210	140	152

VP10 PB SERIES PLASTIC BODY PUMP

VESTA POMP
Makes life comfortable



APPLICATION AREAS

 WASTE WATER TREATMENT	 MINING - ENERGY
 TEXTILE	 MARINE
 PACKAGING	 MACHINE-AUTOMATION
 CHEMICAL INDUSTRY	 BATTERY ACCUMULATOR
 AUTOMOTIVE	 COATING INDUSTRY
 FOOD INDUSTRY	 DEFENSE INDUSTRY
 PAINT INDUSTRY	

ADVANTAGES

- 1) Solid particles may pass through the pump.
- 2) Maintenance cost is low.
- 3) Liquid flow rate can also be adjusted when the air inlet pressure of the pump is adjusted.
- 4) The pump's air valve and pilot valve repair kits can be repaired without disassembling the pump.
- 5) It has the feature of working dry.
- 6) The suction depth of this pump is 6 m.

PUMP TECHNICAL SPECIFICATIONS

Max. Capacity	: 150 l/min
Fluid Inlet-Outlet	: 1"
Max. Fluid Discharge	: 7 bar
Body Material	: PB(Glass fiber added polypropylene)
Air Inlet Size	: 1/2"
Solid Particle Size	: 4 mm
Dry Suction Depth	: 6 m
Max Air Pressure	: 7 bar
Diaphragm Options	: Santoprene, Neoprene, Buna-N, EPDM, Teflon, Viton
Ball Options	: Santoprene, Neoprene, Buna-N, EPDM, Teflon, Viton
Ball Seat Options	: Santoprene, Neoprene, Buna-N, EPDM, Teflon, Viton

DIAPHRAGM PUMPS PERFORMANCE CURVES

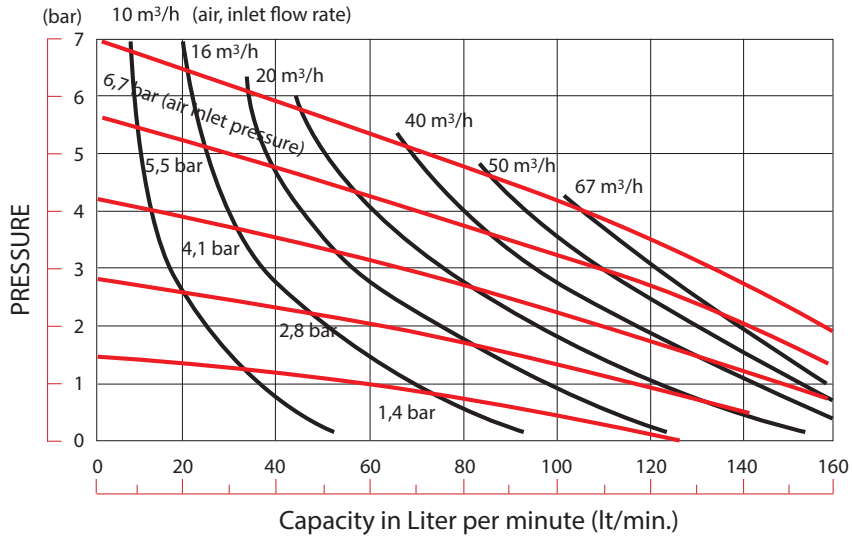

PUMP EXTERNAL DIMENSIONS

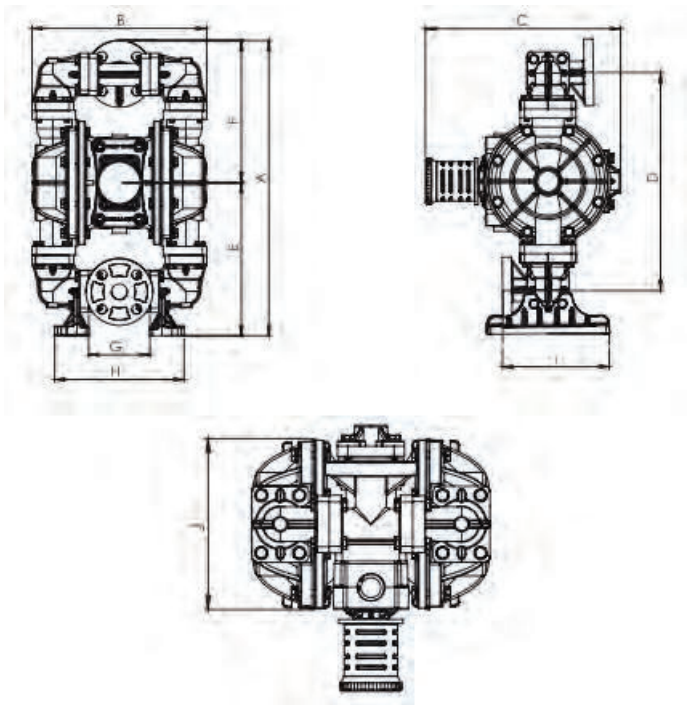

A	B	C	D	E	F	G	H	I	J
482	285	318	356	250	232	100	211	174	205

VP15 PB SERIES PLASTIC BODY PUMP



APPLICATION AREAS

 WASTE WATER TREATMENT	 MINING - ENERGY
 TEXTILE	 MARINE
 PACKAGING	 MACHINE-AUTOMATION
 CHEMICAL INDUSTRY	 BATTERY ACCUMULATOR
 AUTOMOTIVE	 COATING INDUSTRY
 FOOD INDUSTRY	 DEFENSE INDUSTRY
 PAINT INDUSTRY	

ADVANTAGES

- 1) Solid particles may pass through the pump.
- 2) Maintenance cost is low.
- 3) Liquid flow rate can also be adjusted when the air inlet pressure of the pump is adjusted.
- 4) The pump's air valve and pilot valve repair kits can be repaired without disassembling the pump.
- 5) It has the feature of working dry.
- 6) The suction depth of this pump is 6 m.

PUMP TECHNICAL SPECIFICATIONS

Max. Capacity	: 400 l/min
Fluid Inlet-Outlet	: 1½"
Max. Fluid Discharge	: 7 bar
Body Material	: PB (Glass fiber added polypropylene)
Air Inlet Size	: 3/4"
Solid Particle Size	: 6 mm
Dry Suction Depth	: 6 m
Max Air Pressure	: 7 bar
Diaphragm Options	: Santoprene, Neoprene, Buna-N, EPDM, Teflon, Viton
Ball Options	: Santoprene, Neoprene, Buna-N, EPDM, Teflon, Viton
Ball Seat Options	: Santoprene, Neoprene, Buna-N, EPDM, Teflon, Viton

DIAPHRAGM PUMPS PERFORMANCE CURVES

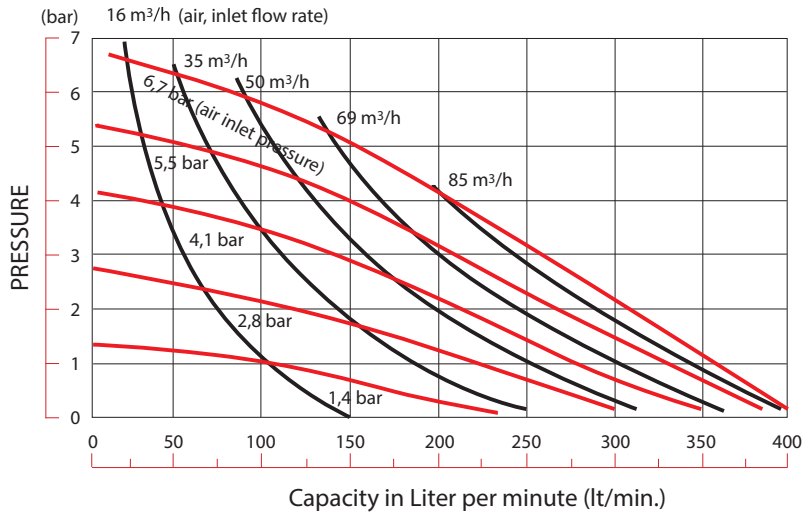

PUMP EXTERNAL DIMENSIONS

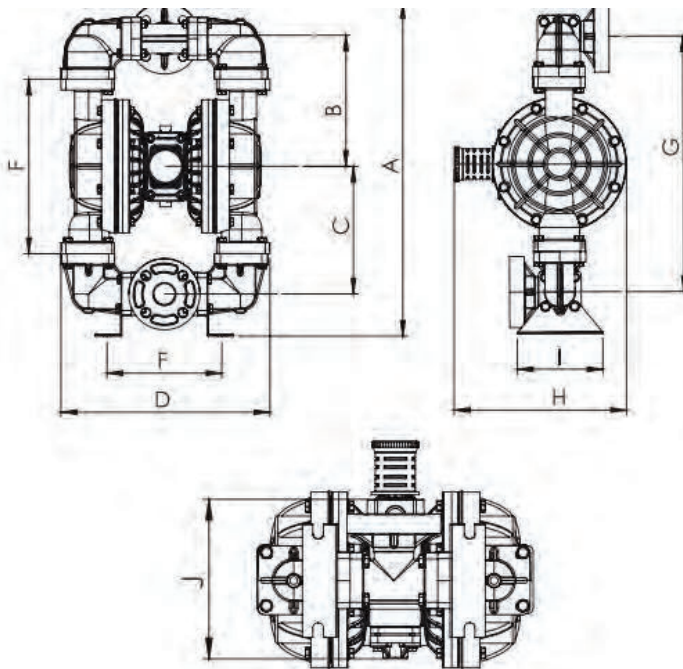

A	B	C	D	E	F	G	H	I	J
703	276	269	440	242	368	538	363	180	254



APPLICATION AREAS

- WASTE WATER TREATMENT
- TEXTILE
- PACKAGING
- CHEMICAL INDUSTRY
- AUTOMOTIVE
- FOOD INDUSTRY
- PAINT INDUSTRY
- MINING - ENERGY
- MARINE
- MACHINE-AUTOMATION
- BATTERY ACCUMULATOR
- COATING INDUSTRY
- DEFENSE INDUSTRY

ADVANTAGES

- 1) Solid particles may pass through the pump.
- 2) Maintenance cost is low.
- 3) Liquid flow rate can also be adjusted when the air inlet pressure of the pump is adjusted.
- 4) The pump's air valve and pilot valve repair kits can be repaired without disassembling the pump.
- 5) It has the feature of working dry.
- 6) The suction depth of this pump is 6 m.

PUMP TECHNICAL SPECIFICATIONS

- Max. Capacity** : 560 l/min
- Fluid Inlet-Outlet** : 2"
- Max. Fluid Discharge** : 7 bar
- Body Material** : PB(Glass fiber added polypropylene)
- Air Inlet Size** : 3/4"
- Solid Particle Size** : 6 mm
- Dry Suction Depth** : 6 m
- Max Air Pressure** : 7 bar
- Diaphragm Options** : Santoprene, Neoprene, Buna-N, EPDM, Teflon, Viton
- Ball Options** : Santoprene, Neoprene, Buna-N, EPDM, Teflon, Viton
- Ball Seat Options** : Santoprene, Neoprene, Buna-N, EPDM, Teflon, Viton

DIAPHRAGM PUMPS PERFORMANCE CURVES

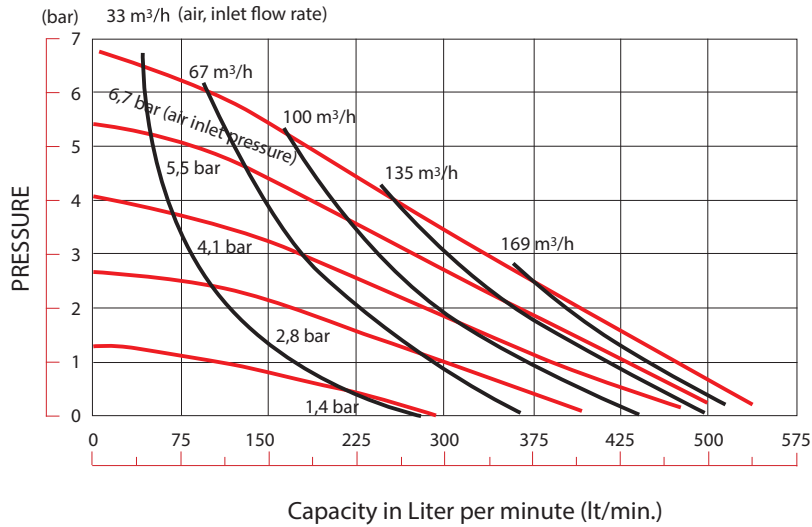

PUMP EXTERNAL DIMENSIONS

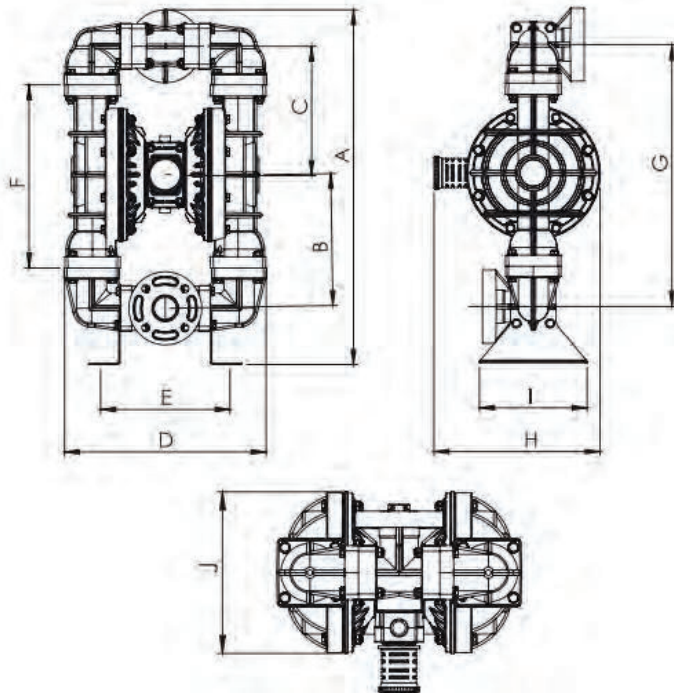

A	B	C	D	E	F	G	H	I	J
790	294	288	450	288	408	584	370	240	298

VP30 PB SERIES PLASTIC BODY PUMP



APPLICATION AREAS

 WASTE WATER TREATMENT	 MINING - ENERGY
 TEXTILE	 MARINE
 PACKAGING	 MACHINE-AUTOMATION
 CHEMICAL INDUSTRY	 BATTERY ACCUMULATOR
 AUTOMOTIVE	 COATING INDUSTRY
 FOOD INDUSTRY	 DEFENSE INDUSTRY
 PAINT INDUSTRY	

ADVANTAGES

- 1) Solid particles may pass through the pump.
- 2) Maintenance cost is low.
- 3) Liquid flow rate can also be adjusted when the air inlet pressure of the pump is adjusted.
- 4) The pump's air valve and pilot valve repair kits can be repaired without disassembling the pump.
- 5) It has the feature of working dry.
- 6) The suction depth of this pump is 6 m.

PUMP TECHNICAL SPECIFICATIONS

Max. Capacity	: 890 l/min
Fluid Inlet-Outlet	: 3"
Max. Fluid Discharge	: 7 bar
Body Material	: PB(Glass fiber added polypropylene)
Air Inlet Size	: 3/4"
Solid Particle Size	: 8 mm
Dry Suction Depth	: 6 m
Max Air Pressure	: 7 bar
Diaphragm Options	: Santoprene, Neoprene, Buna-N, EPDM, Teflon, Viton
Ball Options	: Santoprene, Neoprene, Buna-N, EPDM, Teflon, Viton
Ball Seat Options	: Santoprene, Neoprene, Buna-N, EPDM, Teflon, Viton

DIAPHRAGM PUMPS PERFORMANCE CURVES

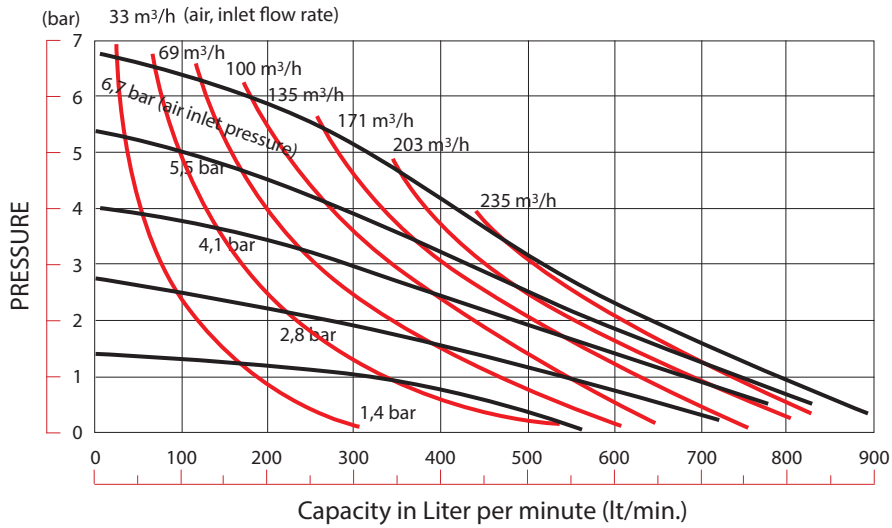

PUMP EXTERNAL DIMENSIONS

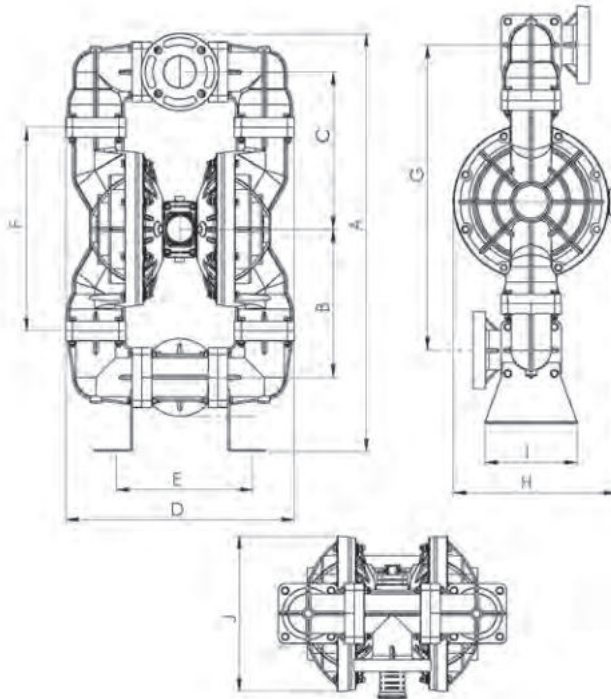

A	B	C	D	E	F	G	H	I	J
1085	385	408	594	353	528	794	424	240	404



APPLICATION AREAS

-  WASTE WATER TREATMENT
-  TEXTILE
-  PACKAGING
-  CHEMICAL INDUSTRY
-  AUTOMOTIVE
-  FOOD INDUSTRY
-  PAINT INDUSTRY

ADVANTAGES

- 1) Solid particles may pass through the pump.
- 2) Maintenance cost is low.
- 3) Liquid flow rate can also be adjusted when the air inlet pressure of the pump is adjusted.
- 4) The pump's air valve and pilot valve repair kits can be repaired without disassembling the pump.
- 5) It has the feature of working dry.
- 6) The suction depth of this pump is 1 m.

PUMP TECHNICAL SPECIFICATIONS

Max. Capacity	: 16 l/min
Fluid Inlet-Outlet	: 1/4"
Max. Fluid Discharge	: 7 bar
Body Material	: Polipropilen - PVDF
Air Inlet Size	: 1/4"
Solid Particle Size	: 1 mm
Dry Suction Depth	: 1m - 1,5 m
Max Air Pressure	: 7 bar
Diaphragm Options	: Santoprene, Neoprene, Buna-N, EPDM, Teflon, Viton
Ball Options	: Santoprene, Neoprene, Buna-N, EPDM, Teflon, Viton
Ball Seat Options	: Santoprene, Neoprene, Buna-N, EPDM, Teflon, Viton

DIAPHRAGM PUMPS PERFORMANCE CURVES

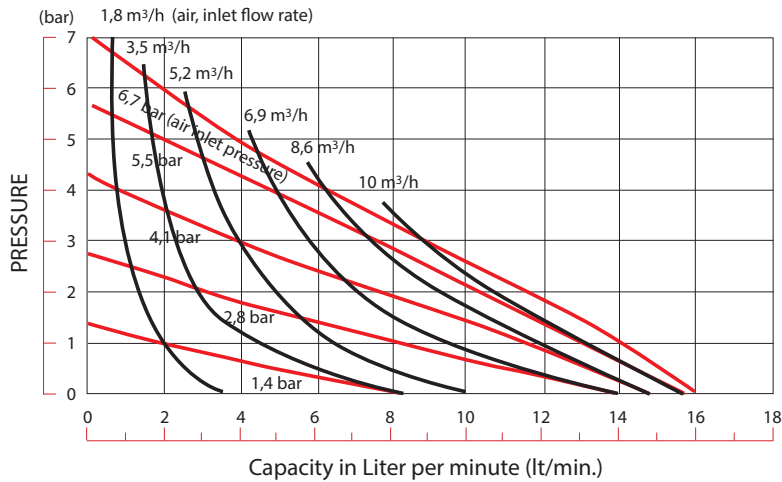

PUMP EXTERNAL DIMENSIONS

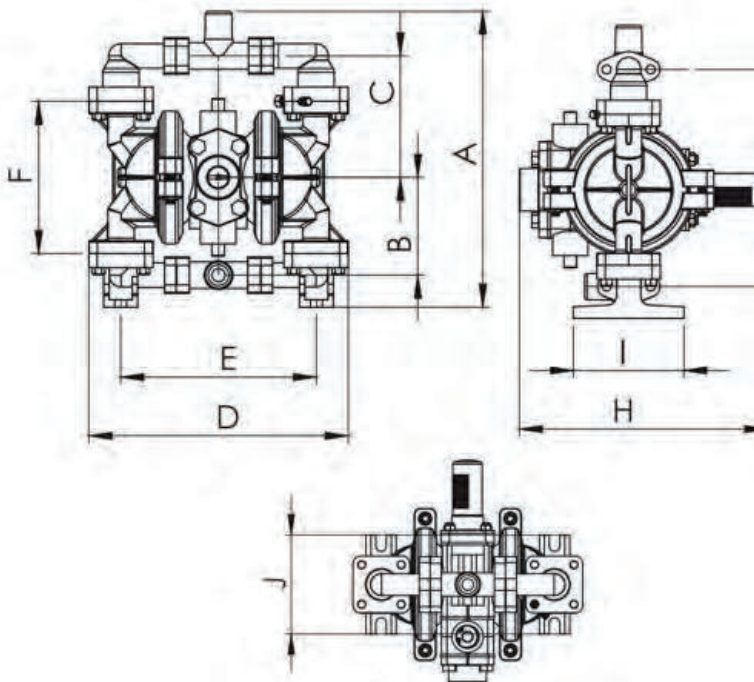

A	B	C	D	E	F	G	H	I	J
212	70	87	186	140	109	157	180	80	80



APPLICATION AREAS

-  WASTE WATER TREATMENT
  MINING - ENERGY
-  TEXTILE
  MARINE
-  PACKAGING
  MACHINE-AUTOMATION
-  CHEMICAL INDUSTRY
-  AUTOMOTIVE
-  FOOD INDUSTRY
-  PAINT INDUSTRY

ADVANTAGES

- 1) Solid particles may pass through the pump.
- 2) Maintenance cost is low.
- 3) Liquid flow rate can also be adjusted when the air inlet pressure of the pump is adjusted.
- 4) The pump's air valve and pilot valve repair kits can be repaired without disassembling the pump.
- 5) It has the feature of working dry.
- 6) The suction depth of this pump is 6 m.

PUMP TECHNICAL SPECIFICATIONS

- Max. Capacity** : 55 l/min
- Fluid Inlet-Outlet** : 3/4"
- Max. Fluid Discharge** : 7 bar
- Body Material** : Polipropilen
- Air Inlet Size** : 1/4"
- Solid Particle Size** : 3 mm
- Dry Suction Depth** : 6 m
- Max Air Pressure** : 7 bar
- Diaphragm Options** : Santoprene, Neoprene, Buna-N, EPDM, Teflon, Viton
- Ball Options** : Santoprene, Neoprene, Buna-N, EPDM, Teflon, Viton
- Ball Seat Options** : Santoprene, Neoprene, Buna-N, EPDM, Teflon, Viton

DIAPHRAGM PUMPS PERFORMANCE CURVES

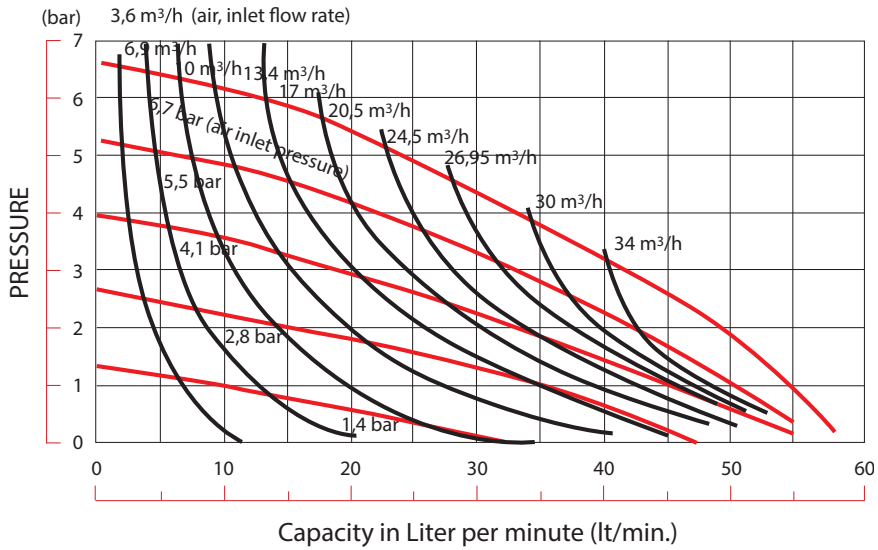

PUMP EXTERNAL DIMENSIONS

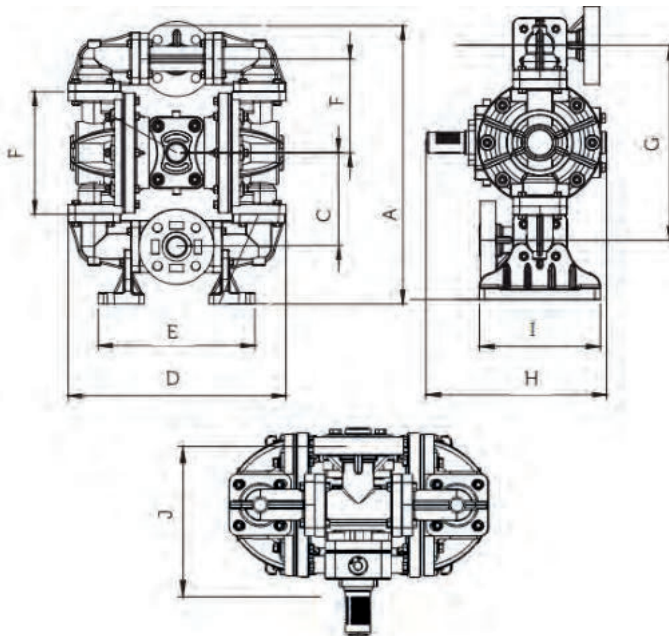

A	B	C	D	E	F	G	H	I	J
340	112	112	262	188	147	225	210	140	152



APPLICATION AREAS

 WASTE WATER TREATMENT	 MINING - ENERGY
 TEXTILE	 MARINE
 PACKAGING	 MACHINE-AUTOMATION
 CHEMICAL INDUSTRY	 BATTERY ACCUMULATOR
 AUTOMOTIVE	 COATING INDUSTRY
 FOOD INDUSTRY	 DEFENSE INDUSTRY
 PAINT INDUSTRY	

ADVANTAGES

- 1) Solid particles may pass through the pump.
- 2) Maintenance cost is low.
- 3) Liquid flow rate can also be adjusted when the air inlet pressure of the pump is adjusted.
- 4) The pump's air valve and pilot valve repair kits can be repaired without disassembling the pump.
- 5) It has the feature of working dry.
- 6) The suction depth of this pump is 6 m.

PUMP TECHNICAL SPECIFICATIONS

Max. Capacity	: 150 l/min
Fluid Inlet-Outlet	: 1"
Max. Fluid Discharge	: 7 bar
Body Material	: Polipropilen
Air Inlet Size	: 1/2"
Solid Particle Size	: 4 mm
Dry Suction Depth	: 6 m
Max Air Pressure	: 7 bar
Diaphragm Options	: Santoprene, Neoprene, Buna-N, EPDM, Teflon, Viton
Ball Options	: Santoprene, Neoprene, Buna-N, EPDM, Teflon, Viton
Ball Seat Options	: Santoprene, Neoprene, Buna-N, EPDM, Teflon, Viton

DIAPHRAGM PUMPS PERFORMANCE CURVES

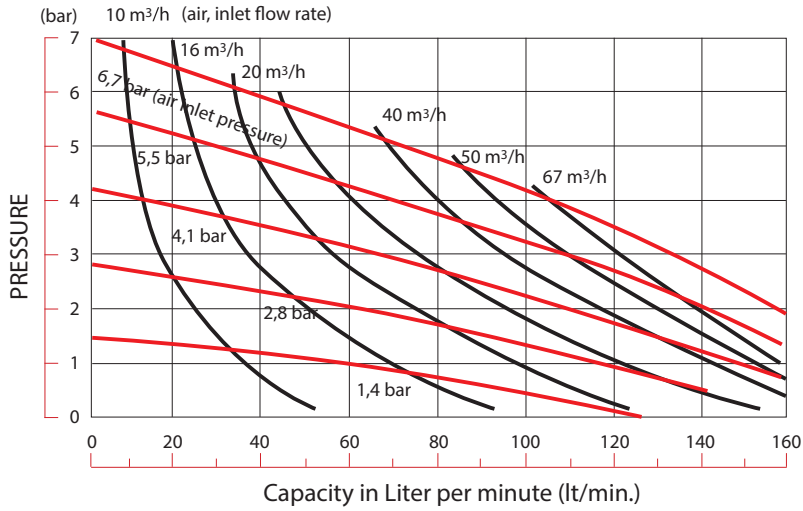

PUMP EXTERNAL DIMENSIONS

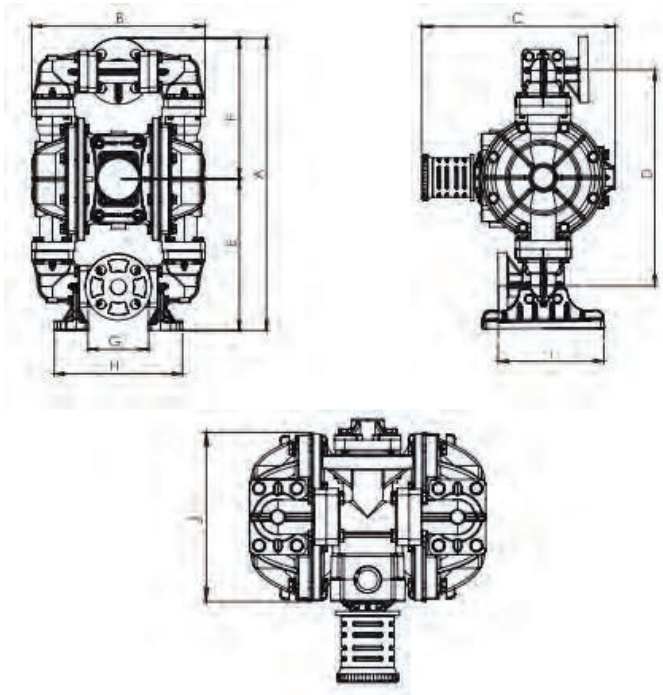

A	B	C	D	E	F	G	H	I	J
482	285	318	356	250	232	100	211	174	205



APPLICATION AREAS

 WASTE WATER TREATMENT	 MINING - ENERGY
 TEXTILE	 MARINE
 PACKAGING	 MACHINE-AUTOMATION
 CHEMICAL INDUSTRY	 BATTERY ACCUMULATOR
 AUTOMOTIVE	 COATING INDUSTRY
 FOOD INDUSTRY	 DEFENSE INDUSTRY
 PAINT INDUSTRY	

ADVANTAGES

- 1) Solid particles may pass through the pump.
- 2) Maintenance cost is low.
- 3) Liquid flow rate can also be adjusted when the air inlet pressure of the pump is adjusted.
- 4) The pump's air valve and pilot valve repair kits can be repaired without disassembling the pump.
- 5) It has the feature of working dry.
- 6) The suction depth of this pump is 6 m.

PUMP TECHNICAL SPECIFICATIONS

Max. Capacity	: 400 l/min
Fluid Inlet-Outlet	: 1½"
Max. Fluid Discharge	: 7 bar
Body Material	: Polipropilen
Air Inlet Size	: 3/4"
Solid Particle Size	: 6 mm
Dry Suction Depth	: 6 m
Max Air Pressure	: 7 bar
Diaphragm Options	: Santoprene, Neoprene, Buna-N, EPDM, Teflon, Viton
Ball Options	: Santoprene, Neoprene, Buna-N, EPDM, Teflon, Viton
Ball Seat Options	: Santoprene, Neoprene, Buna-N, EPDM, Teflon, Viton

DIAPHRAGM PUMPS PERFORMANCE CURVES

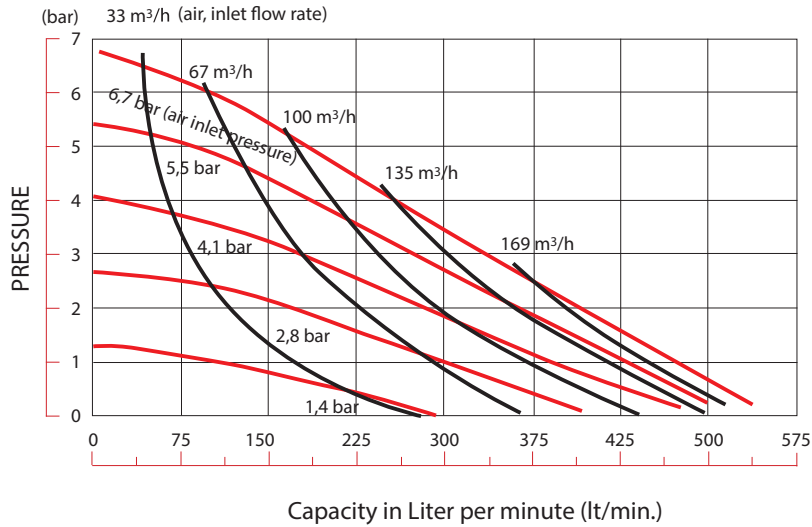

PUMP EXTERNAL DIMENSIONS

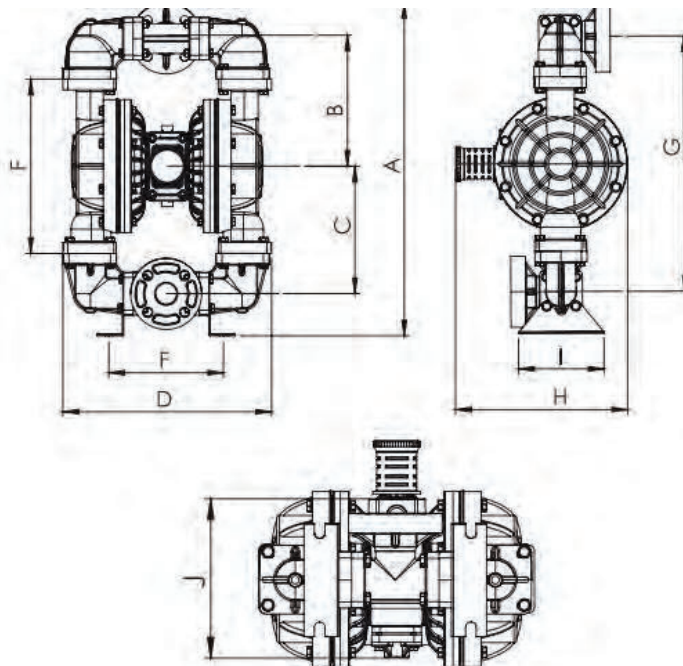

A	B	C	D	E	F	G	H	I	J
703	276	269	440	242	368	538	363	180	254



APPLICATION AREAS

-  WASTE WATER TREATMENT
  MINING - ENERGY
-  TEXTILE
  MARINE
-  PACKAGING
  MACHINE-AUTOMATION
-  CHEMICAL INDUSTRY
  BATTERY ACCUMULATOR
-  AUTOMOTIVE
  COATING INDUSTRY
-  FOOD INDUSTRY
  DEFENSE INDUSTRY
-  PAINT INDUSTRY

ADVANTAGES

- 1) Solid particles may pass through the pump.
- 2) Maintenance cost is low.
- 3) Liquid flow rate can also be adjusted when the air inlet pressure of the pump is adjusted.
- 4) The pump's air valve and pilot valve repair kits can be repaired without disassembling the pump.
- 5) It has the feature of working dry.
- 6) The suction depth of this pump is 6 m.

PUMP TECHNICAL SPECIFICATIONS

- Max. Capacity** : 560 l/min
- Fluid Inlet-Outlet** : 2"
- Max. Fluid Discharge** : 7 bar
- Body Material** : Polipropilen
- Air Inlet Size** : 3/4"
- Solid Particle Size** : 6 mm
- Dry Suction Depth** : 6 m
- Max Air Pressure** : 7 bar
- Diaphragm Options** : Santoprene, Neoprene, Buna-N, EPDM, Teflon, Viton
- Ball Options** : Santoprene, Neoprene, Buna-N, EPDM, Teflon, Viton
- Ball Seat Options** : Santoprene, Neoprene, Buna-N, EPDM, Teflon, Viton

DIAPHRAGM PUMPS PERFORMANCE CURVES

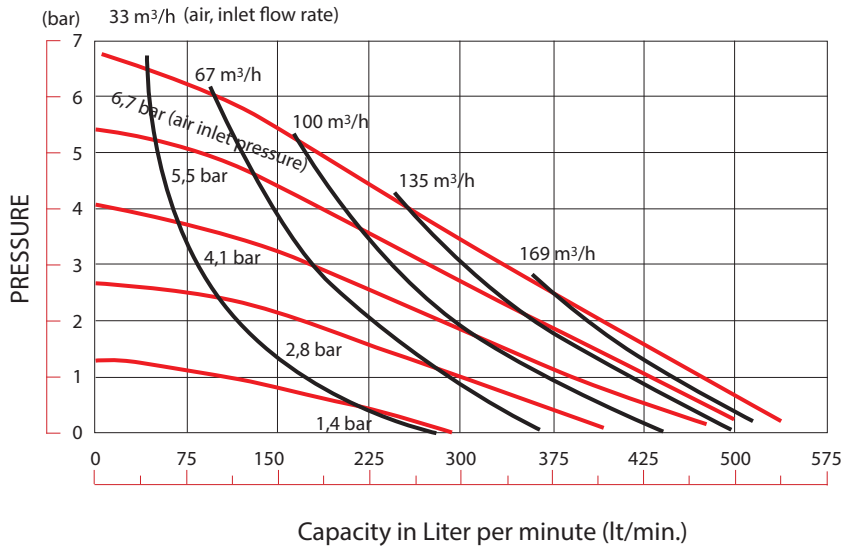

PUMP EXTERNAL DIMENSIONS

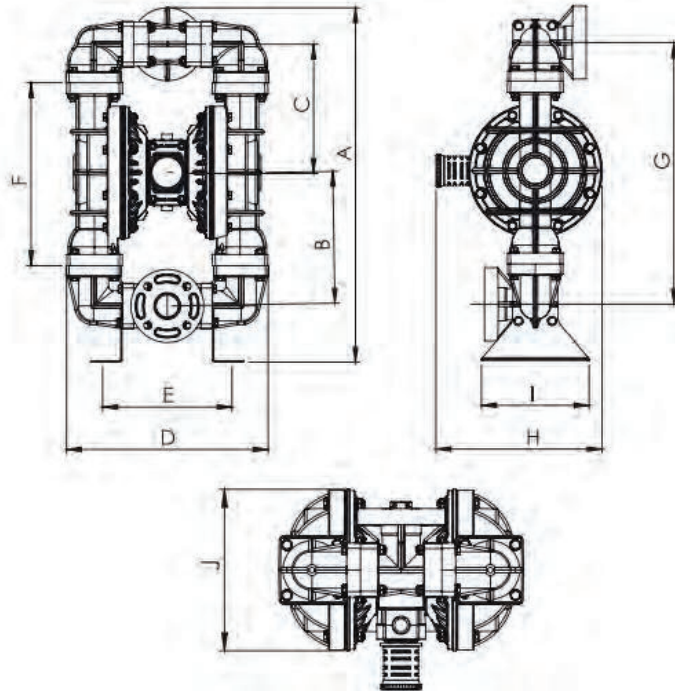

A	B	C	D	E	F	G	H	I	J
790	294	288	450	288	408	584	370	240	298

VPO2 PP SERIES PLASTIC BODY PUMP (SIDED INLET/OUTLET)

VESTA POMP
Makes life comfortable



APPLICATION AREAS

-  WASTE WATER TREATMENT
-  TEXTILE
-  PACKAGING
-  CHEMICAL INDUSTRY
-  AUTOMOTIVE
-  FOOD INDUSTRY
-  PAINT INDUSTRY

ADVANTAGES

- 1) Solid particles may pass through the pump.
- 2) Maintenance cost is low.
- 3) Liquid flow rate can also be adjusted when the air inlet pressure of the pump is adjusted.
- 4) The pump's air valve and pilot valve repair kits can be repaired without disassembling the pump.
- 5) It has the feature of working dry.
- 6) The suction depth of this pump is 1 m.

PUMP TECHNICAL SPECIFICATIONS

- Max. Capacity** : 16 l/min
- Fluid Inlet-Outlet** : 1/4"
- Max. Fluid Discharge** : 7 bar
- Body Material** : Polipropilen, PB (Glass fiber added polypropylene), PVDF
- Air Inlet Size** : 1/4"
- Solid Particle Size** : 1 mm
- Dry Suction Depth** : 1m - 1,5 m
- Max Air Pressure** : 7 bar
- Diaphragm Options** : Santoprene, Neoprene, Buna-N, EPDM, Teflon, Viton
- Ball Options** : Santoprene, Neoprene, Buna-N, EPDM, Teflon, Viton
- Ball Seat Options** : Santoprene, Neoprene, Buna-N, EPDM, Teflon, Viton

DIAPHRAGM PUMPS PERFORMANCE CURVES

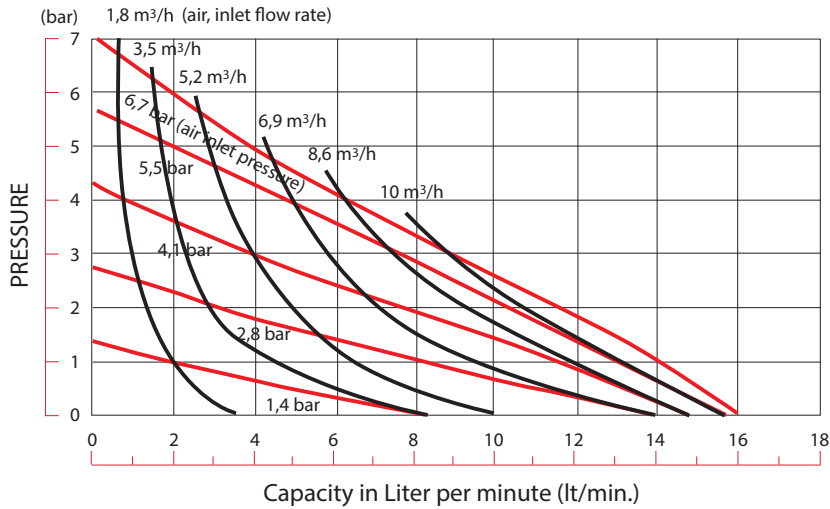

PUMP EXTERNAL DIMENSIONS

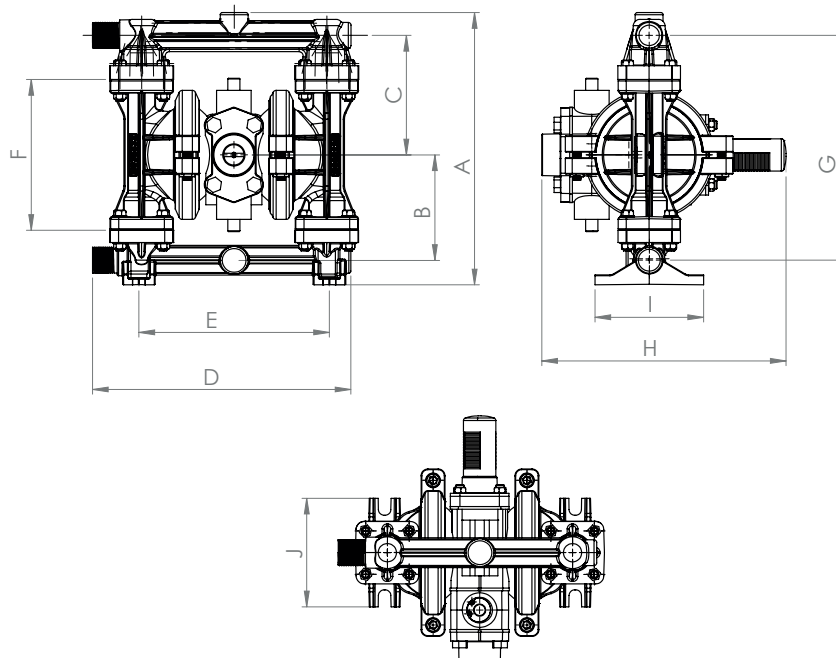

A	B	C	D	E	F	G	H	I	J
200	78	88	190	140	111	166	180	80	80

VPO5 PP SERIES PLASTIC BODY PUMP (SIDED INLET/OUTLET)

VESTA POMP
Makes life comfortable



APPLICATION AREAS

- WASTE WATER TREATMENT
- TEXTILE
- PACKAGING
- CHEMICAL INDUSTRY
- AUTOMOTIVE
- FOOD INDUSTRY
- PAINT INDUSTRY
- MINING - ENERGY
- MARINE
- MACHINE-AUTOMATION

ADVANTAGES

- 1) Solid particles may pass through the pump.
- 2) Maintenance cost is low.
- 3) Liquid flow rate can also be adjusted when the air inlet pressure of the pump is adjusted.
- 4) The pump's air valve and pilot valve repair kits can be repaired without disassembling the pump.
- 5) It has the feature of working dry.
- 6) The suction depth of this pump is 6 m.

PUMP TECHNICAL SPECIFICATIONS

- Max. Capacity** : 55 l/min
- Fluid Inlet-Outlet** : 3/4"
- Max. Fluid Discharge** : 7 bar
- Body Material** : Polipropilen, PB (Glass fiber added polypropylene, PVDF)
- Air Inlet Size** : 1/4"
- Solid Particle Size** : 3 mm
- Dry Suction Depth** : 6 m
- Max Air Pressure** : 7 bar
- Diaphragm Options** : Santoprene, Neoprene, Buna-N, EPDM, Teflon, Viton
- Ball Options** : Santoprene, Neoprene, Buna-N, EPDM, Teflon, Viton
- Ball Seat Options** : Santoprene, Neoprene, Buna-N, EPDM, Teflon, Viton

DIAPHRAGM PUMPS PERFORMANCE CURVES

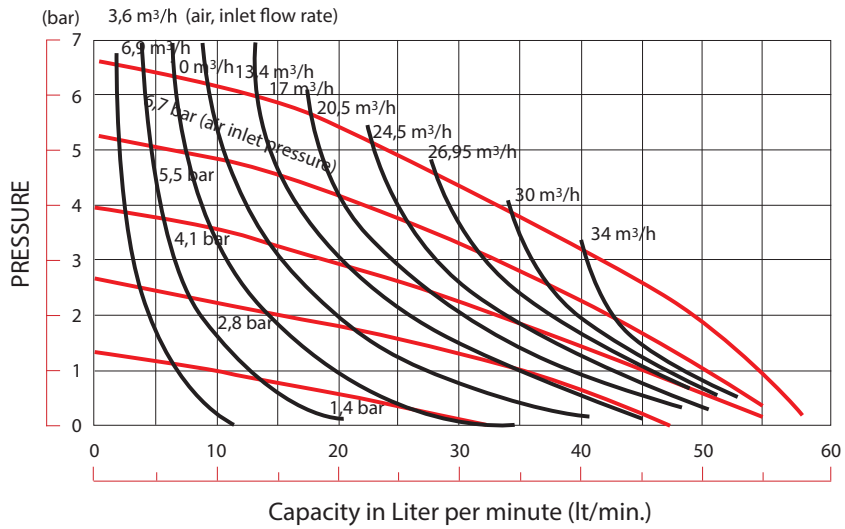

PUMP EXTERNAL DIMENSIONS

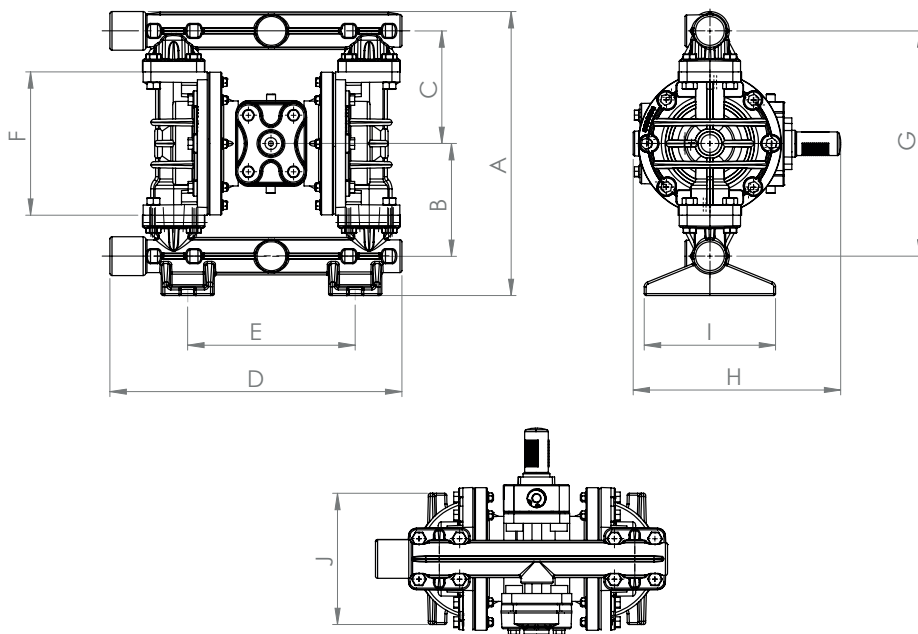

A	B	C	D	E	F	G	H	I	J
286	114	114	294	169	145	227	209	132	132

VP10 PP SERIES PLASTIC BODY PUMP (SIDED INLET/OUTLET)

VESTA POMP
Makes life comfortable



APPLICATION AREAS

- WASTE WATER TREATMENT
- TEXTILE
- PACKAGING
- CHEMICAL INDUSTRY
- AUTOMOTIVE
- FOOD INDUSTRY
- PAINT INDUSTRY
- MINING - ENERGY
- MARINE
- MACHINE-AUTOMATION
- BATTERY ACCUMULATOR
- COATING INDUSTRY
- DEFENSE INDUSTRY

ADVANTAGES

- 1) Solid particles may pass through the pump.
- 2) Maintenance cost is low.
- 3) Liquid flow rate can also be adjusted when the air inlet pressure of the pump is adjusted.
- 4) The pump's air valve and pilot valve repair kits can be repaired without disassembling the pump.
- 5) It has the feature of working dry.
- 6) The suction depth of this pump is 6 m.

PUMP TECHNICAL SPECIFICATIONS

- Max. Capacity** : 150 l/min
- Fluid Inlet-Outlet** : 1"
- Max. Fluid Discharge** : 7 bar
- Body Material** : Polipropilen, PB (Glass fiber added polypropylene), PVDF
- Air Inlet Size** : 1/2"
- Solid Particle Size** : 4 mm
- Dry Suction Depth** : 6 m
- Max Air Pressure** : 7 bar
- Diaphragm Options** : Santoprene, Neoprene, Buna-N, EPDM, Teflon, Viton
- Ball Options** : Santoprene, Neoprene, Buna-N, EPDM, Teflon, Viton
- Ball Seat Options** : Santoprene, Neoprene, Buna-N, EPDM, Teflon, Viton

VP10 PP SERIES PLASTIC BODY PUMP (SIDED INLET/OUTLET)

DIAPHRAGM PUMPS PERFORMANCE CURVES

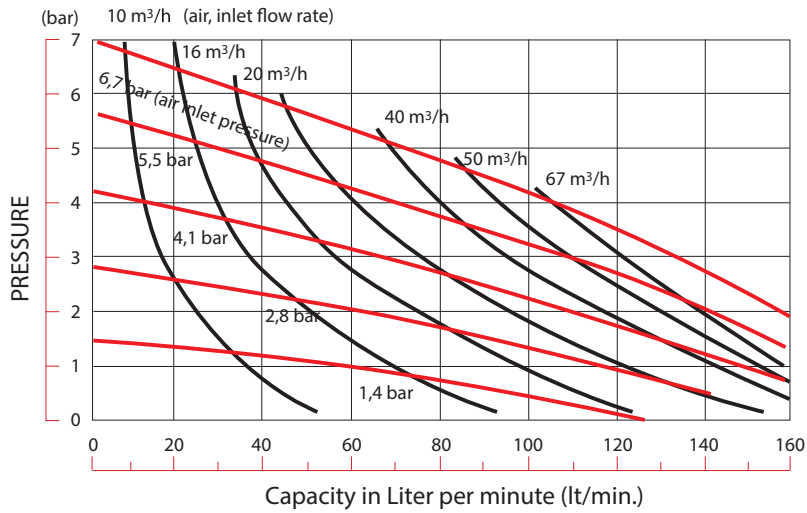

PUMP EXTERNAL DIMENSIONS

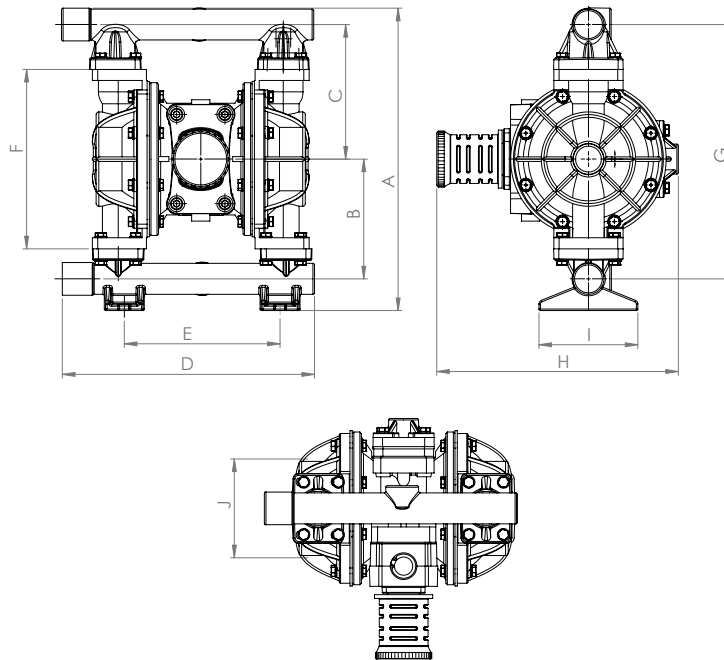

A	B	C	D	E	F	G	H	I	J
398	158	177	332	205	236	335	318	130	130



APPLICATION AREAS

-  WASTE WATER TREATMENT
-  TEXTILE
-  PACKAGING
-  CHEMICAL INDUSTRY
-  AUTOMOTIVE
-  FOOD INDUSTRY
-  PAINT INDUSTRY

ADVANTAGES

- 1) Solid particles may pass through the pump.
- 2) Maintenance cost is low.
- 3) Liquid flow rate can also be adjusted when the air inlet pressure of the pump is adjusted.
- 4) The pump's air valve and pilot valve repair kits can be repaired without disassembling the pump.
- 5) It has the feature of working dry.
- 6) The suction depth of this pump is 1 m.

PUMP TECHNICAL SPECIFICATIONS

- Max. Capacity** : 16 l/min
- Fluid Inlet-Outlet** : 1/4"
- Max. Fluid Discharge** : 7 bar
- Body Material** : PVDF
- Air Inlet Size** : 1/4"
- Solid Particle Size** : 1 mm
- Dry Suction Depth** : 1m - 1,5 m
- Max Air Pressure** : 7 bar
- Diaphragm Options** : Santoprene, Neoprene, Buna-N, EPDM, Teflon, Viton
- Ball Options** : Santoprene, Neoprene, Buna-N, EPDM, Teflon, Viton
- Ball Seat Options** : Santoprene, Neoprene, Buna-N, EPDM, Teflon, Viton

DIAPHRAGM PUMPS PERFORMANCE CURVES

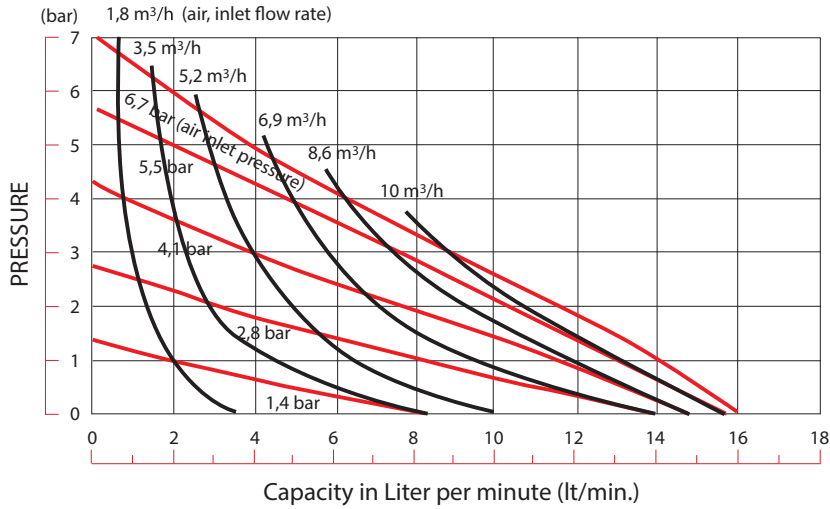

PUMP EXTERNAL DIMENSIONS

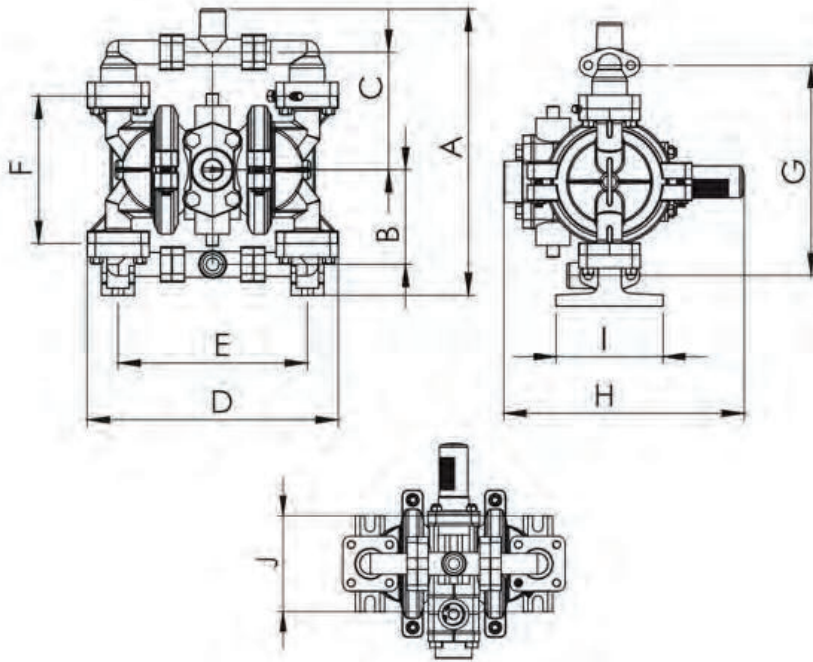

A	B	C	D	E	F	G	H	I	J
212	70	87	186	140	109	157	180	80	80



APPLICATION AREAS

- 

WASTE WATER TREATMENT
- 

MINING - ENERGY
- 

TEXTILE
- 

MARINE
- 

PACKAGING
- 

MACHINE-AUTOMATION
- 

CHEMICAL INDUSTRY
- 

AUTOMOTIVE
- 

FOOD INDUSTRY
- 

PAINT INDUSTRY

ADVANTAGES

- 1) Solid particles may pass through the pump.
- 2) Maintenance cost is low.
- 3) Liquid flow rate can also be adjusted when the air inlet pressure of the pump is adjusted.
- 4) The pump's air valve and pilot valve repair kits can be repaired without disassembling the pump.
- 5) It has the feature of working dry.
- 6) The suction depth of this pump is 6 m.
- 7) The liquid connection of the pump can be both flange and threaded.

PUMP TECHNICAL SPECIFICATIONS

- Max. Capacity** : 55 l/min
- Fluid Inlet-Outlet** : 3/4"
- Max. Fluid Discharge** : 7 bar
- Body Material** : PVDF
- Air Inlet Size** : 1/4"
- Solid Particle Size** : 3 mm
- Dry Suction Depth** : 6 m
- Max Air Pressure** : 7 bar
- Diaphragm Options** : Santoprene, Neoprene, Buna-N, EPDM, Teflon, Viton
- Ball Options** : Santoprene, Neoprene, Buna-N, EPDM, Teflon, Viton
- Ball Seat Options** : Santoprene, Neoprene, Buna-N, EPDM, Teflon, Viton

DIAPHRAGM PUMPS PERFORMANCE CURVES

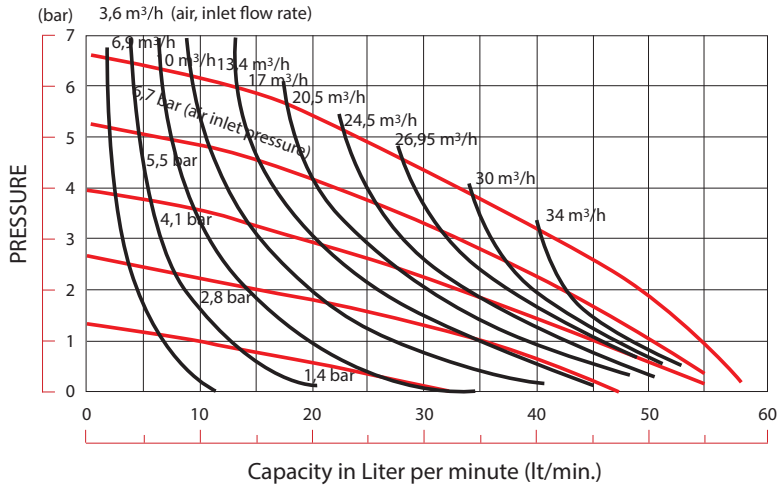

PUMP EXTERNAL DIMENSIONS

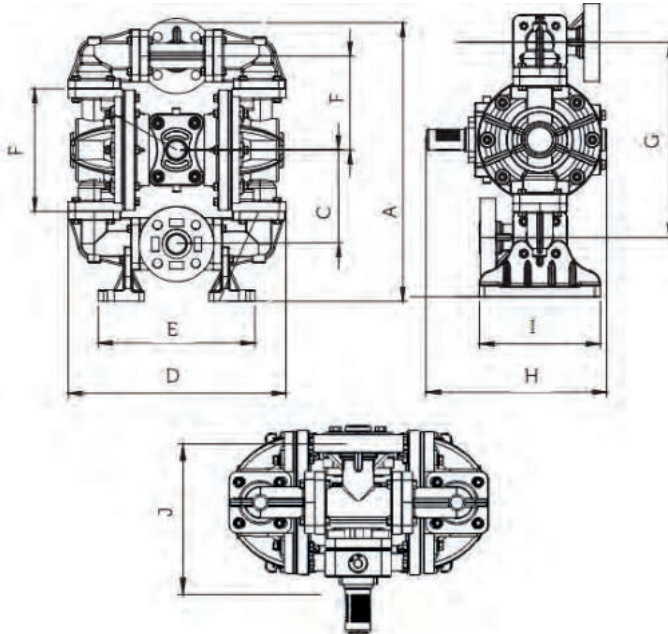

A	B	C	D	E	F	G	H	I	J
340	112	112	262	188	147	225	210	140	152



APPLICATION AREAS

	WASTE WATER TREATMENT		MINING - ENERGY
	TEXTILE		MARINE
	PACKAGING		MACHINE-AUTOMATION
	CHEMICAL INDUSTRY		BATTERY ACCUMULATOR
	AUTOMOTIVE		COATING INDUSTRY
	FOOD INDUSTRY		DEFENSE INDUSTRY
	PAINT INDUSTRY		

ADVANTAGES

- 1) Solid particles may pass through the pump.
- 2) Maintenance cost is low.
- 3) Liquid flow rate can also be adjusted when the air inlet pressure of the pump is adjusted.
- 4) The pump's air valve and pilot valve repair kits can be repaired without disassembling the pump.
- 5) It has the feature of working dry.
- 6) The suction depth of this pump is 6 m.
- 7) The liquid connection of the pump can be both flange and threaded.

PUMP TECHNICAL SPECIFICATIONS

Max. Capacity	: 150 l/min
Fluid Inlet-Outlet	: 1"
Max. Fluid Discharge	: 7 bar
Body Material	: PVDF
Air Inlet Size	: ½"
Solid Particle Size	: 4 mm
Dry Suction Depth	: 6 m
Max Air Pressure	: 7 bar
Diaphragm Options	: Santoprene, Neoprene, Buna-N, EPDM, Teflon, Viton
Ball Options	: Santoprene, Neoprene, Buna-N, EPDM, Teflon, Viton
Ball Seat Options	: Santoprene, Neoprene, Buna-N, EPDM, Teflon, Viton

DIAPHRAGM PUMPS PERFORMANCE CURVES

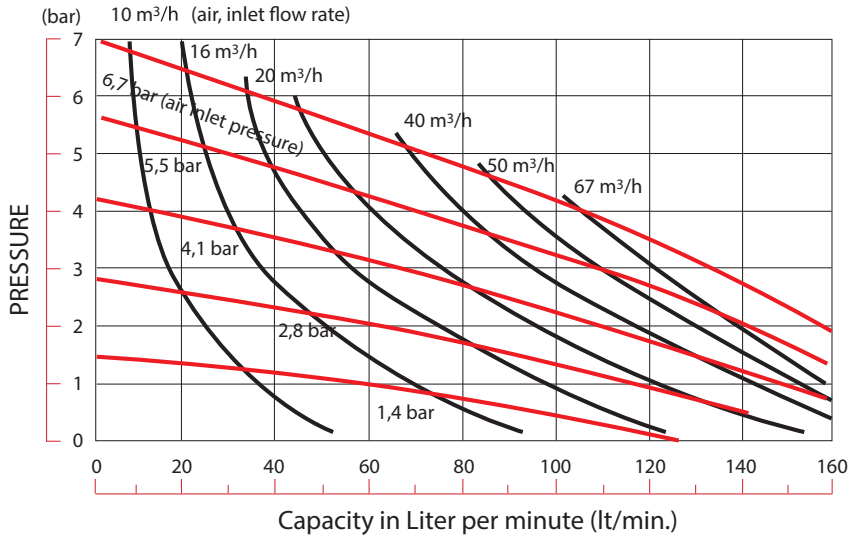

PUMP EXTERNAL DIMENSIONS

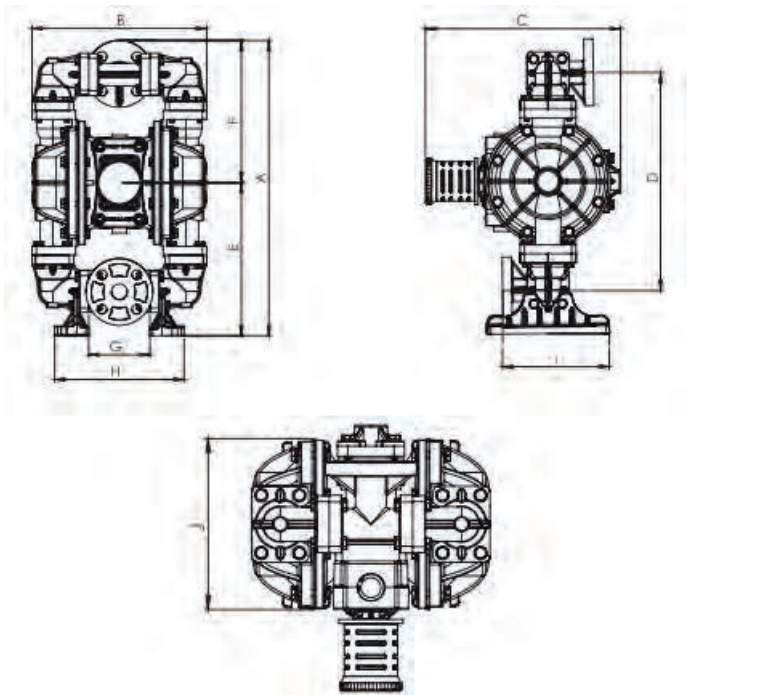

A	B	C	D	E	F	G	H	I	J
482	285	318	356	250	232	100	211	174	205



APPLICATION AREAS

	WASTE WATER TREATMENT		MINING - ENERGY
	TEXTILE		MARINE
	PACKAGING		MACHINE-AUTOMATION
	CHEMICAL INDUSTRY		BATTERY ACCUMULATOR
	AUTOMOTIVE		COATING INDUSTRY
	FOOD INDUSTRY		DEFENSE INDUSTRY
	PAINT INDUSTRY		

ADVANTAGES

- 1) Solid particles may pass through the pump.
- 2) Maintenance cost is low.
- 3) Liquid flow rate can also be adjusted when the air inlet pressure of the pump is adjusted.
- 4) The pump's air valve and pilot valve repair kits can be repaired without disassembling the pump.
- 5) It has the feature of working dry.
- 6) The suction depth of this pump is 6 m.
- 7) The liquid connection of the pump can be both flange and threaded.

PUMP TECHNICAL SPECIFICATIONS

Max. Capacity	: 400 l/min
Fluid Inlet-Outlet	: 1½"
Max. Fluid Discharge	: 7 bar
Body Material	: PVDF
Air Inlet Size	: 3/4"
Solid Particle Size	: 6 mm
Dry Suction Depth	: 6 m
Max Air Pressure	: 7 bar
Diaphragm Options	: Santoprene, Neoprene, Buna-N, EPDM, Teflon, Viton
Ball Options	: Santoprene, Neoprene, Buna-N, EPDM, Teflon, Viton
Ball Seat Options	: Santoprene, Neoprene, Buna-N, EPDM, Teflon, Viton

DIAPHRAGM PUMPS PERFORMANCE CURVES

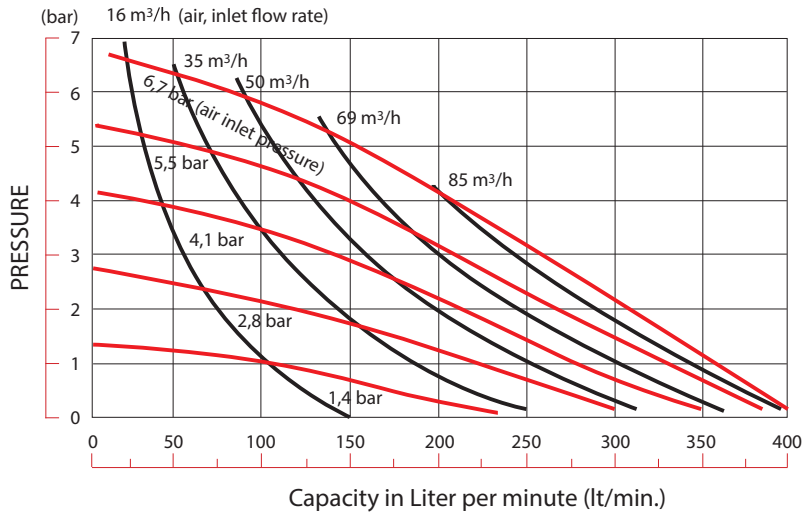

PUMP EXTERNAL DIMENSIONS

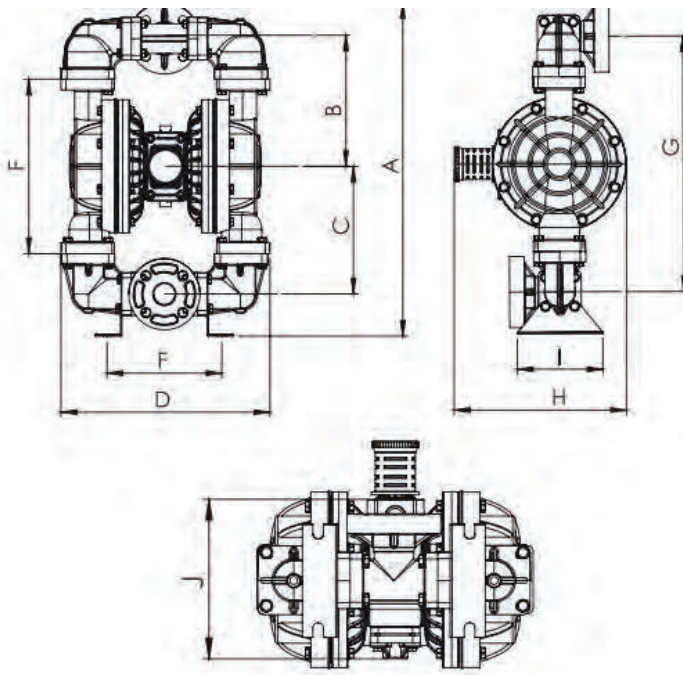

A	B	C	D	E	F	G	H	I	J
703	276	269	440	242	368	538	363	180	254



APPLICATION AREAS

- WASTE WATER TREATMENT
- TEXTILE
- PACKAGING
- CHEMICAL INDUSTRY
- AUTOMOTIVE
- FOOD INDUSTRY
- PAINT INDUSTRY
- MINING - ENERGY
- MARINE
- MACHINE-AUTOMATION
- BATTERY ACCUMULATOR
- COATING INDUSTRY
- DEFENSE INDUSTRY

ADVANTAGES

- 1) Solid particles may pass through the pump.
- 2) Maintenance cost is low.
- 3) Liquid flow rate can also be adjusted when the air inlet pressure of the pump is adjusted.
- 4) The pump's air valve and pilot valve repair kits can be repaired without disassembling the pump.
- 5) It has the feature of working dry.
- 6) The suction depth of this pump is 6 m.
- 7) The liquid connection of the pump can be both flange and threaded.

PUMP TECHNICAL SPECIFICATIONS

- Max. Capacity** : 560 l/min
- Fluid Inlet-Outlet** : 2"
- Max. Fluid Discharge** : 7 bar
- Body Material** : PVDF
- Air Inlet Size** : 3/4"
- Solid Particle Size** : 6 mm
- Dry Suction Depth** : 6 m
- Max Air Pressure** : 7 bar
- Diaphragm Options** : Santoprene, Neoprene, Buna-N, EPDM, Teflon, Viton
- Ball Options** : Santoprene, Neoprene, Buna-N, EPDM, Teflon, Viton
- Ball Seat Options** : Santoprene, Neoprene, Buna-N, EPDM, Teflon, Viton

DIAPHRAGM PUMPS PERFORMANCE CURVES

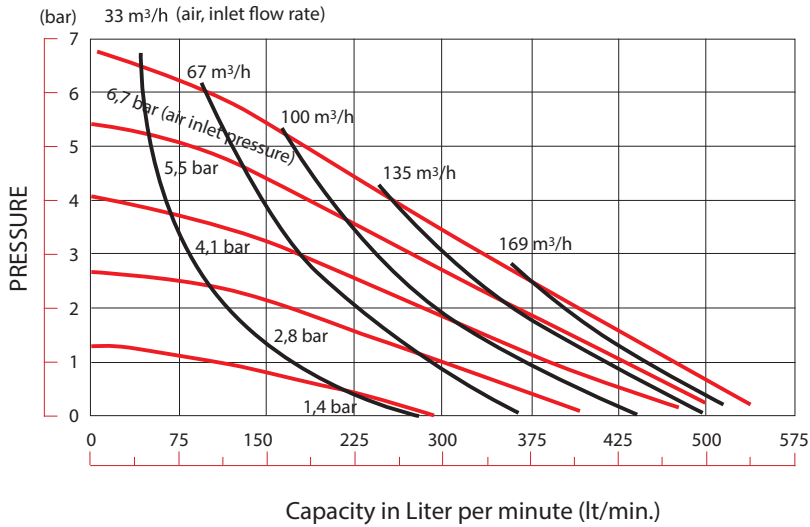

PUMP EXTERNAL DIMENSIONS

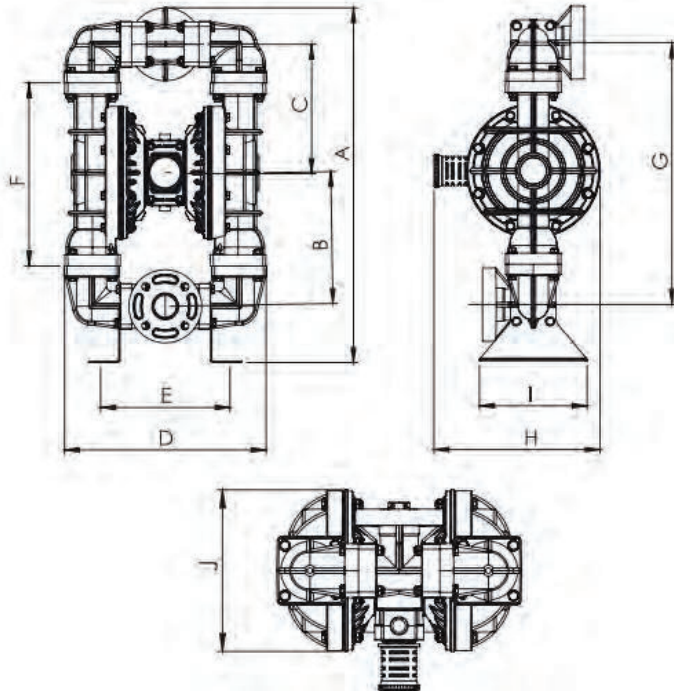

A	B	C	D	E	F	G	H	I	J
790	294	288	450	288	408	584	370	240	298



APPLICATION AREAS

 WASTE WATER TREATMENT	 MINING - ENERGY
 TEXTILE	 MARINE
 PACKAGING	 MACHINE-AUTOMATION
 CHEMICAL INDUSTRY	 BATTERY ACCUMULATOR
 AUTOMOTIVE	 COATING INDUSTRY
 FOOD INDUSTRY	 DEFENSE INDUSTRY
 PAINT INDUSTRY	

ADVANTAGES

- 1) Solid particles may pass through the pump.
- 2) Maintenance cost is low.
- 3) Liquid flow rate can also be adjusted when the air inlet pressure of the pump is adjusted.
- 4) The pump's air valve and pilot valve repair kits can be repaired without disassembling the pump.
- 5) It has the feature of working dry.
- 6) The suction depth of this pump is 6 m.
- 7) The liquid connection of the pump can be both flange and threaded.

PUMP TECHNICAL SPECIFICATIONS

Max. Capacity	: 890 l/min
Fluid Inlet-Outlet	: 3"
Max. Fluid Discharge	: 7 bar
Body Material	: PVDF
Air Inlet Size	: 3/4"
Solid Particle Size	: 8 mm
Dry Suction Depth	: 6 m
Max Air Pressure	: 7 bar
Diaphragm Options	: Santoprene, Neoprene, Buna-N, EPDM, Teflon, Viton
Ball Options	: Santoprene, Neoprene, Buna-N, EPDM, Teflon, Viton
Ball Seat Options	: Santoprene, Neoprene, Buna-N, EPDM, Teflon, Viton

DIAPHRAGM PUMPS PERFORMANCE CURVES

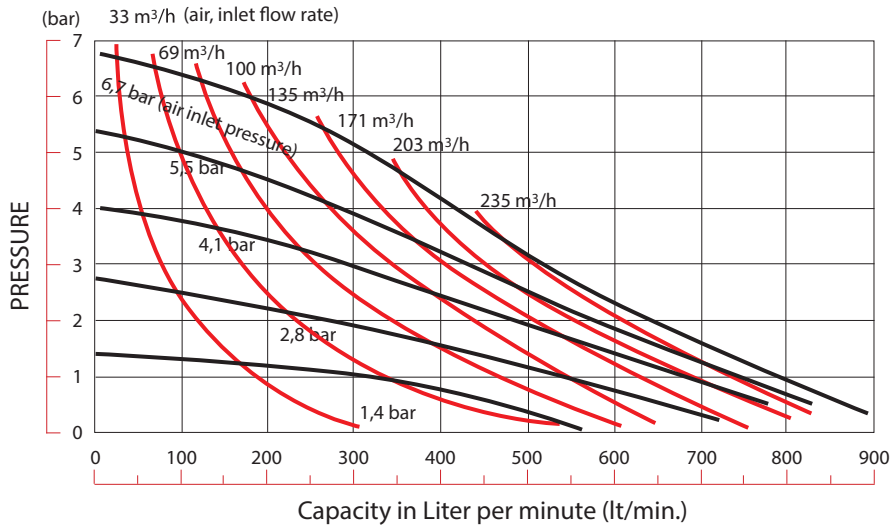

PUMP EXTERNAL DIMENSIONS

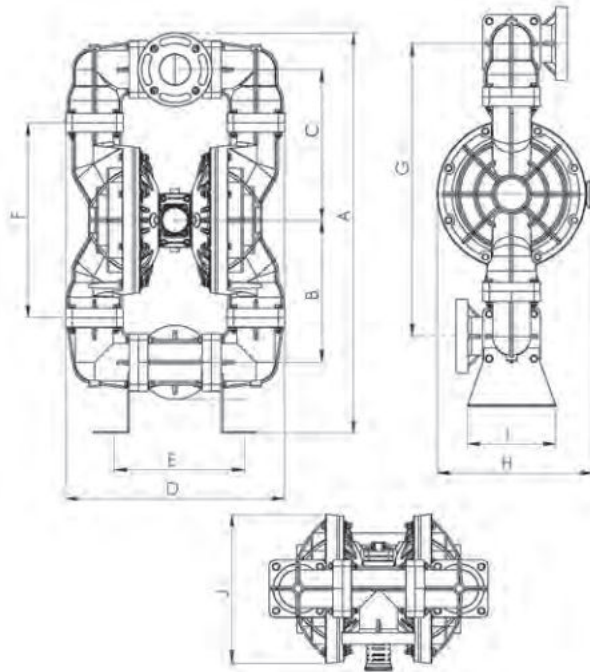

A	B	C	D	E	F	G	H	I	J
1085	385	408	594	353	528	794	424	240	404



APPLICATION AREAS

- 

WASTE WATER TREATMENT
- 

MINING - ENERGY
- 

TEXTILE
- 

MARINE
- 

PACKAGING
- 

MACHINE-AUTOMATION
- 

CHEMICAL INDUSTRY
- 

AUTOMOTIVE
- 

FOOD INDUSTRY
- 

PAINT INDUSTRY

ADVANTAGES

- 1) Solid particles may pass through the pump.
- 2) Maintenance cost is low.
- 3) Liquid flow rate can also be adjusted when the air inlet pressure of the pump is adjusted.
- 4) The pump's air valve and pilot valve repair kits can be repaired without disassembling the pump.
- 5) It has the feature of working dry.
- 6) The suction depth of this pump is 6 m.
- 7) The liquid connection of the pump can be both flange and threaded.

PUMP TECHNICAL SPECIFICATIONS

- Max. Capacity** : 55 l/min
- Fluid Inlet-Outlet** : 3/4"
- Max. Fluid Discharge** : 7 bar
- Body Material** : Polipropilen, Polipropilen Black, PVDF
- Air Inlet Size** : 1/4"
- Solid Particle Size** : 3 mm
- Dry Suction Depth** : 6 m
- Max Air Pressure** : 7 bar
- Diaphragm Options** : Santoprene, Neoprene, Buna-N, EPDM, Teflon, Viton
- Ball Options** : Santoprene, Neoprene, Buna-N, EPDM, Teflon, Viton
- Ball Seat Options** : Santoprene, Neoprene, Buna-N, EPDM, Teflon, Viton

DIAPHRAGM PUMPS PERFORMANCE CURVES

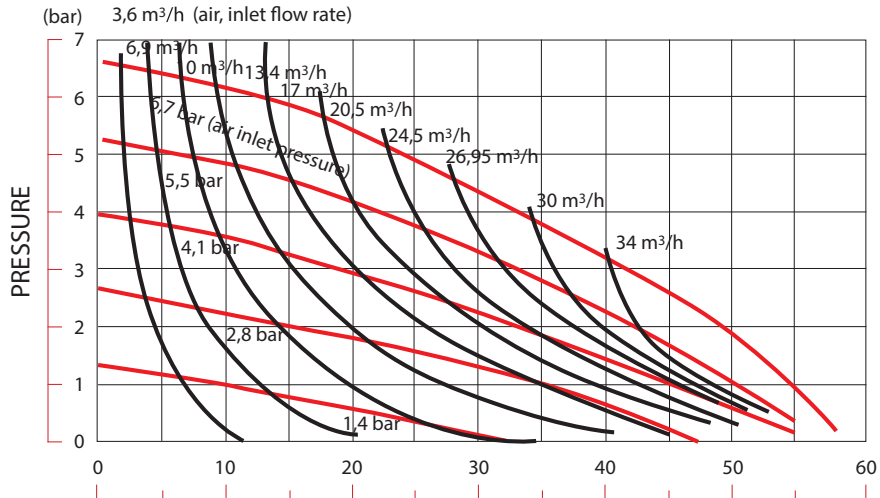

PUMP EXTERNAL DIMENSIONS

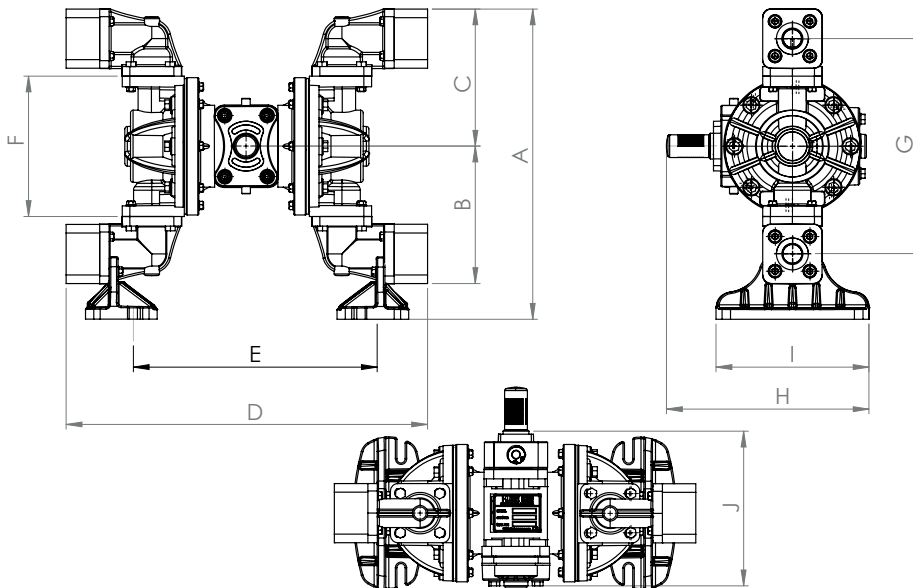

A	B	C	D	E	F	G	H	I	J
325	144	144	380	255	147	255	212	160	162



APPLICATION AREAS

- 

WASTE WATER TREATMENT
- 

MINING - ENERGY
- 

TEXTILE
- 

MARINE
- 

PACKAGING
- 

MACHINE-AUTOMATION
- 

CHEMICAL INDUSTRY
- 

BATTERY ACCUMULATOR
- 

AUTOMOTIVE
- 

COATING INDUSTRY
- 

FOOD INDUSTRY
- 

DEFENSE INDUSTRY
- 

PAINT INDUSTRY

ADVANTAGES

- 1) Solid particles may pass through the pump.
- 2) Maintenance cost is low.
- 3) Liquid flow rate can also be adjusted when the air inlet pressure of the pump is adjusted.
- 4) The pump's air valve and pilot valve repair kits can be repaired without disassembling the pump.
- 5) It has the feature of working dry.
- 6) The suction depth of this pump is 6 m.
- 7) The liquid connection of the pump can be both flange and threaded.

PUMP TECHNICAL SPECIFICATIONS

- Max. Capacity** : 150 l/min
- Fluid Inlet-Outlet** : 1"
- Max. Fluid Discharge** : 7 bar
- Body Material** : Polipropilen, Polipropilen Black, PVDF
- Air Inlet Size** : 1/2"
- Solid Particle Size** : 4 mm
- Dry Suction Depth** : 6 m
- Max Air Pressure** : 7 bar
- Diaphragm Options** : Santoprene, Neoprene, Buna-N, EPDM, Teflon, Viton
- Ball Options** : Santoprene, Neoprene, Buna-N, EPDM, Teflon, Viton
- Ball Seat Options** : Santoprene, Neoprene, Buna-N, EPDM, Teflon, Viton

DIAPHRAGM PUMPS PERFORMANCE CURVES

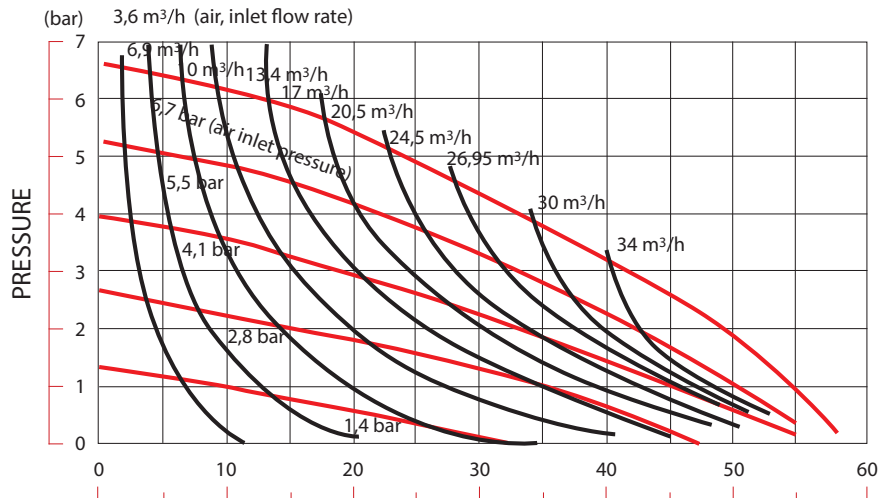

PUMP EXTERNAL DIMENSIONS

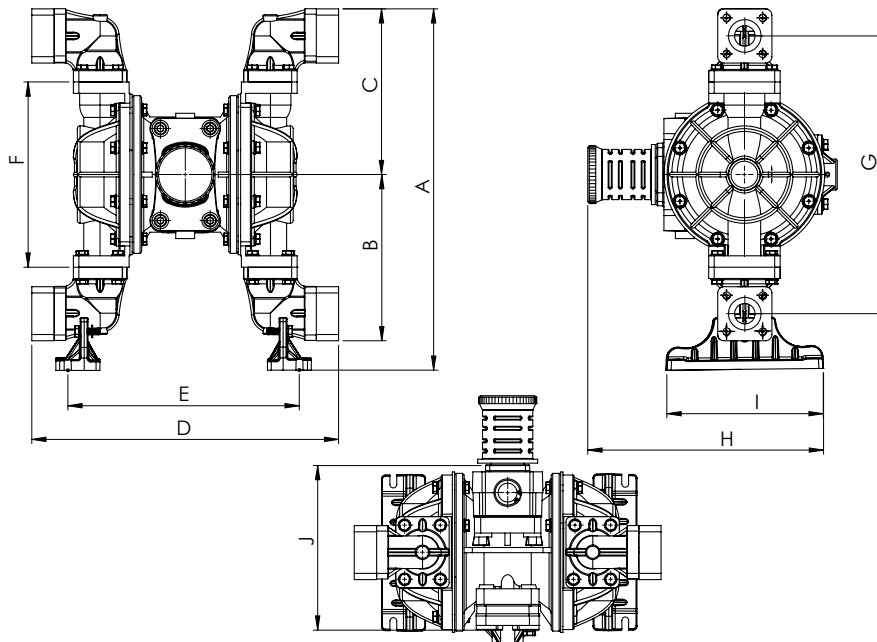

A	B	C	D	E	F	G	H	I	J
460	212	212	390	295	236	354	300	200	210

VPO5 ATEX METALLIC BODY PUMP

VESTA POMP
Makes life comfortable



APPLICATION AREAS

- WASTE WATER TREATMENT
- TEXTILE
- PACKAGING
- CHEMICAL INDUSTRY
- AUTOMOTIVE
- FOOD INDUSTRY
- PAINT INDUSTRY
- MINING - ENERGY
- MARINE
- MACHINE-AUTOMATION

ADVANTAGES

- 1) Solid particles may pass through the pump.
- 2) The pump is ex-proof. (Suitable for explosive and flammable fluids.)
- 3) Maintenance cost is low.
- 4) Liquid flow rate can also be adjusted when the air inlet pressure of the pump is adjusted.
- 5) The pump's air valve and pilot valve repair kits can be repaired without disassembling the pump.
- 6) It has the feature of working dry.
- 7) The suction depth of this pump is 6 m.

PUMP TECHNICAL SPECIFICATIONS

- Max. Capacity** : 55 l/min
- Fluid Inlet-Outlet** : 3/4"
- Max. Fluid Discharge** : 7 bar
- Body Material** : Aluminum, Casting, Stainless Steel
- Air Inlet Size** : 1/4"
- Solid Particle Size** : 3 mm
- Dry Suction Depth** : 6 m
- Max Air Pressure** : 7 bar
- Diaphragm Options** : Santoprene, Neoprene, Buna-N, EPDM, Teflon, Viton
- Ball Options** : Santoprene, Neoprene, Buna-N, EPDM, Teflon, Viton
- Ball Seat Options** : Santoprene, Neoprene, Buna-N, EPDM, Teflon, Viton



Ex h IIB T(80°C) Gb
Ex h IIIB T(80°C) Db
Ex h I M2 T(80°C) Mb

Note: The valve parts of the pumps are made of conductive polypropylene.

DIAPHRAGM PUMPS PERFORMANCE CURVES

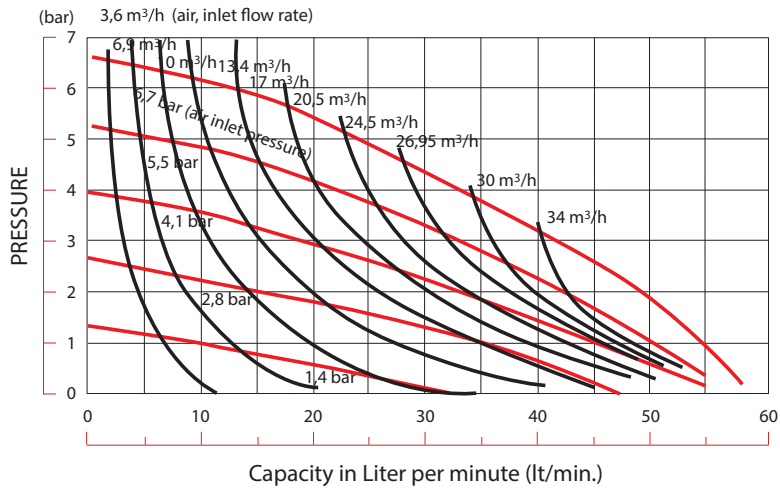

PUMP EXTERNAL DIMENSIONS

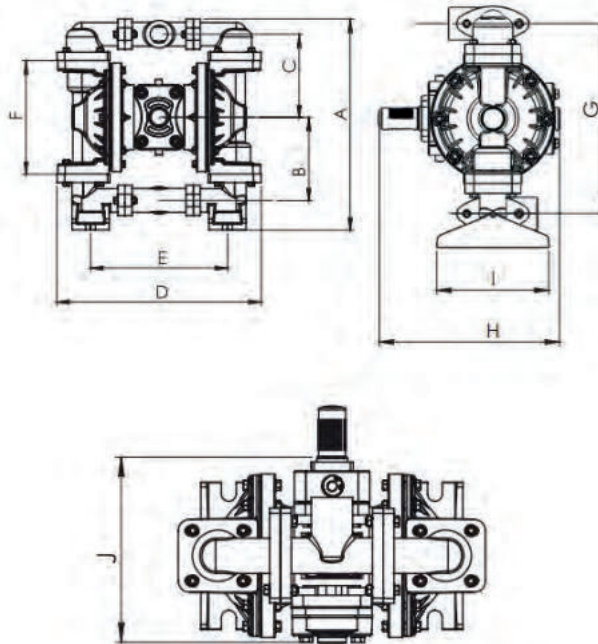

A	B	C	D	E	F	G	H	I	J
279	110	110	270	181	150	220	209	130	163



APPLICATION AREAS

-  WASTE WATER TREATMENT
-  MARINE
-  TEXTILE
-  MACHINE-AUTOMATION
-  PACKAGING
-  DEFENSE INDUSTRY
-  AUTOMOTIVE
-  PETROL AND OIL
-  FOOD INDUSTRY
-  CERAMIC INDUSTRY
-  PAINT INDUSTRY
-  MEDICAL INDUSTRY
-  MINING - ENERGY

ADVANTAGES

- 1) Solid particles may pass through the pump.
- 2) The pump is ex-proof. (Suitable for explosive and flammable fluids.)
- 3) Maintenance cost is low.
- 4) Liquid flow rate can also be adjusted when the air inlet pressure of the pump is adjusted.
- 5) The pump's air valve and pilot valve repair kits can be repaired without disassembling the pump.
- 6) It has the feature of working dry.
- 7) The suction depth of this pump is 6 m.

PUMP TECHNICAL SPECIFICATIONS

- Max. Capacity** : 150 l/min
- Fluid Inlet-Outlet** : 1"
- Max. Fluid Discharge** : 7 bar
- Body Material** : Aluminum, Casting, Stainless Steel
- Air Inlet Size** : ½"
- Solid Particle Size** : 4 mm
- Dry Suction Depth** : 6 m
- Max Air Pressure** : 7 bar
- Diaphragm Options** : Santoprene, Neoprene, Buna-N, EPDM, Teflon, Viton
- Ball Options** : Santoprene, Neoprene, Buna-N, EPDM, Teflon, Viton
- Ball Seat Options** : Santoprene, Neoprene, Buna-N, EPDM, Teflon, Viton



Ex h IIB T(80°C) Gb
Ex h IIIB T(80°C) Db
Ex h I M2 T(80°C) Mb

Note: The valve parts of the pumps are made of conductive polypropylene.

DIAPHRAGM PUMPS PERFORMANCE CURVES

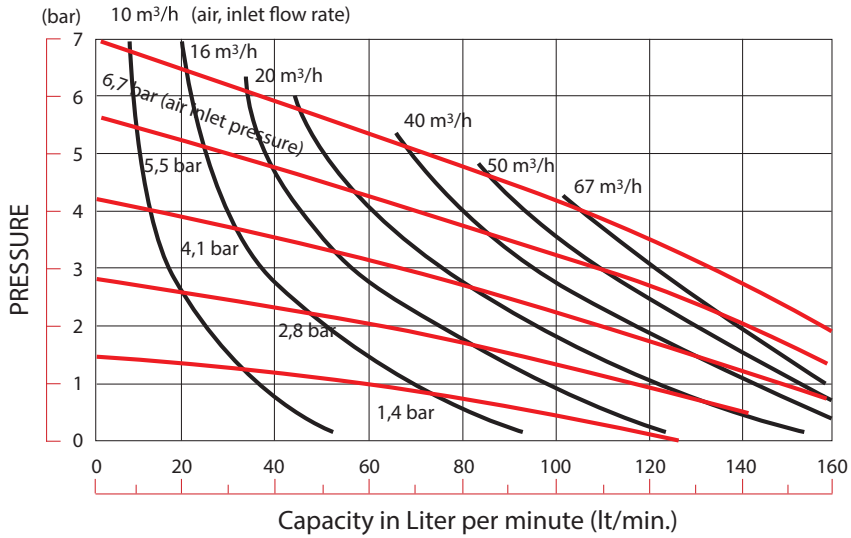

PUMP EXTERNAL DIMENSIONS

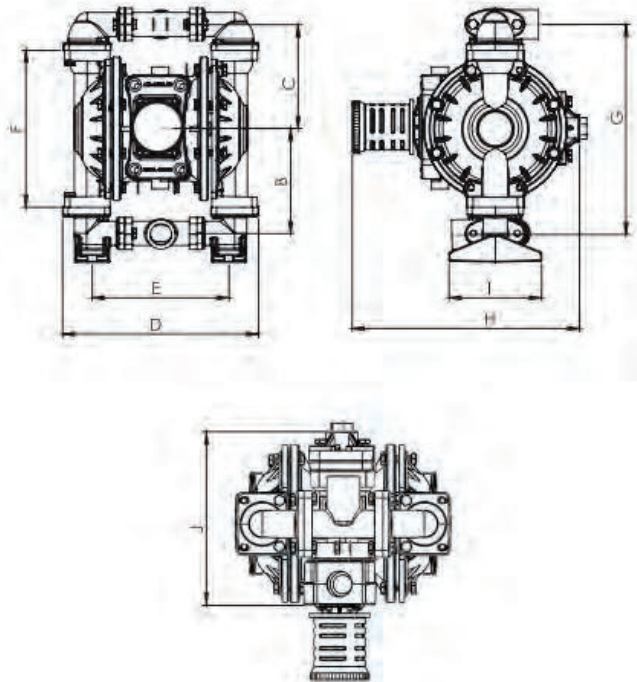

A	B	C	D	E	F	G	H	I	J
356	146	146	274	191	220	293	312	130	220



APPLICATION AREAS

-  WASTE WATER TREATMENT
-  MARINE
-  TEXTILE
-  MACHINE-AUTOMATION
-  PACKAGING
-  DEFENSE INDUSTRY
-  AUTOMOTIVE
-  PETROL AND OIL
-  FOOD INDUSTRY
-  CERAMIC INDUSTRY
-  PAINT INDUSTRY
-  MEDICAL INDUSTRY
-  MINING - ENERGY

ADVANTAGES

- 1) Solid particles may pass through the pump.
- 2) The pump is ex-proof. (Suitable for explosive and flammable fluids.)
- 3) Maintenance cost is low.
- 4) Liquid flow rate can also be adjusted when the air inlet pressure of the pump is adjusted.
- 5) The pump's air valve and pilot valve repair kits can be repaired without disassembling the pump.
- 6) It has the feature of working dry.
- 7) The suction depth of this pump is 6 m.

PUMP TECHNICAL SPECIFICATIONS

- Max. Capacity** : 400 l/min
- Fluid Inlet-Outlet** : 1½"
- Max. Fluid Discharge** : 7 bar
- Body Material** : Aluminum, Casting, Stainless Steel
- Air Inlet Size** : 3/4"
- Solid Particle Size** : 6 mm
- Dry Suction Depth** : 6 m
- Max Air Pressure** : 7 bar
- Diaphragm Options** : Santoprene, Neoprene, Buna-N, EPDM, Teflon, Viton
- Ball Options** : Santoprene, Neoprene, Buna-N, EPDM, Teflon, Viton
- Ball Seat Options** : Santoprene, Neoprene, Buna-N, EPDM, Teflon, Viton



Ex h IIB T(80°C) Gb
Ex h IIIB T(80°C) Db
Ex h I M2 T(80°C) Mb

Note: The valve parts of the pumps are made of conductive polypropylene.

DIAPHRAGM PUMPS PERFORMANCE CURVES

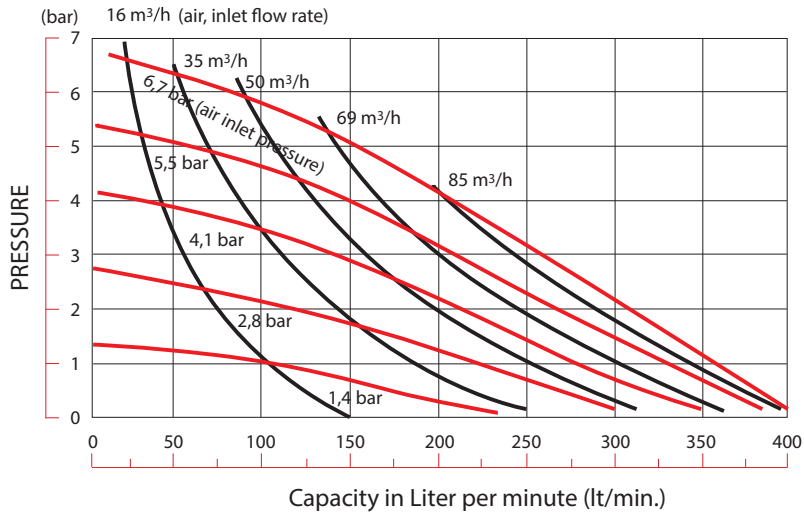

PUMP EXTERNAL DIMENSIONS

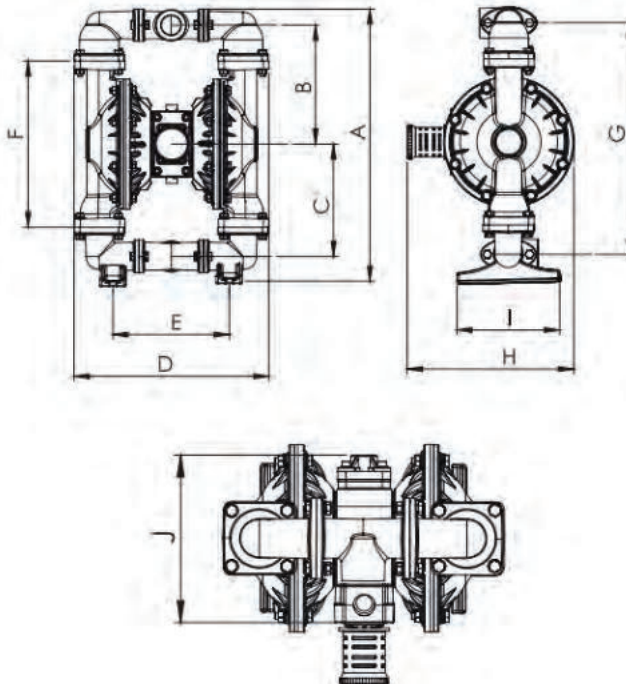

A	B	C	D	E	F	G	H	I	J
605	260	245	425	253	363	505	363	224	253



APPLICATION AREAS

-  WASTE WATER TREATMENT
-  MARINE
-  TEXTILE
-  MACHINE-AUTOMATION
-  PACKAGING
-  DEFENSE INDUSTRY
-  AUTOMOTIVE
-  PETROL AND OIL
-  FOOD INDUSTRY
-  CERAMIC INDUSTRY
-  PAINT INDUSTRY
-  MEDICAL INDUSTRY
-  MINING - ENERGY

ADVANTAGES

- 1) Solid particles may pass through the pump.
- 2) The pump is ex-proof. (Suitable for explosive and flammable fluids.)
- 3) Maintenance cost is low.
- 4) Liquid flow rate can also be adjusted when the air inlet pressure of the pump is adjusted.
- 5) The pump's air valve and pilot valve repair kits can be repaired without disassembling the pump.
- 6) It has the feature of working dry.
- 7) The suction depth of this pump is 6 m.

PUMP TECHNICAL SPECIFICATIONS

- Max. Capacity** : 560 l/min
- Fluid Inlet-Outlet** : 2"
- Max. Fluid Discharge** : 7 bar
- Body Material** : Aluminum, Casting, Stainless Steel
- Air Inlet Size** : 3/4"
- Solid Particle Size** : 6 mm
- Dry Suction Depth** : 6 m
- Max Air Pressure** : 7 bar
- Diaphragm Options** : Santoprene, Neoprene, Buna-N, EPDM, Teflon, Viton
- Ball Options** : Santoprene, Neoprene, Buna-N, EPDM, Teflon, Viton
- Ball Seat Options** : Santoprene, Neoprene, Buna-N, EPDM, Teflon, Viton



Ex h IIB T(80°C) Gb
Ex h IIIB T(80°C) Db
Ex h I M2 T(80°C) Mb

Note: The valve parts of the pumps are made of conductive polypropylene.

DIAPHRAGM PUMPS PERFORMANCE CURVES

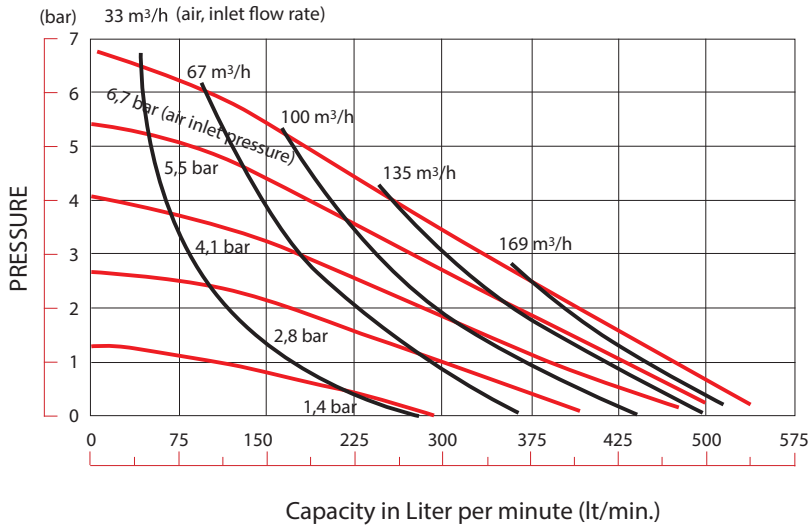

PUMP EXTERNAL DIMENSIONS

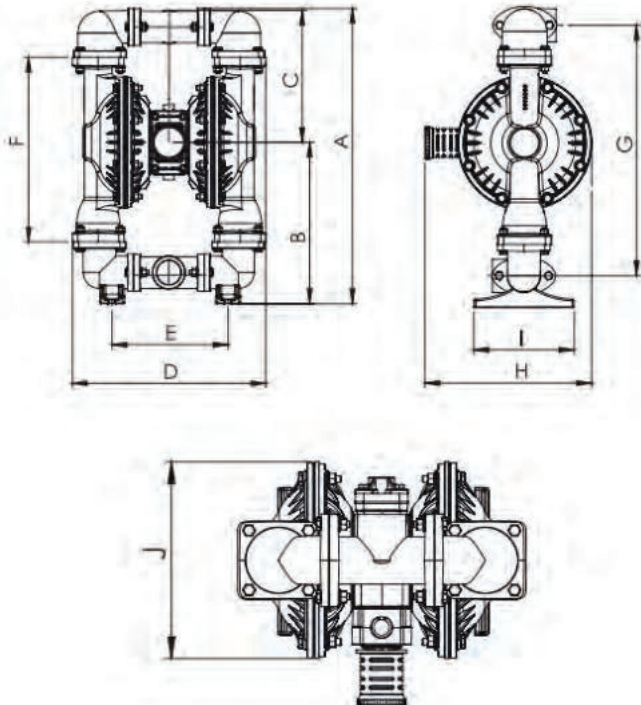

A	B	C	D	E	F	G	H	I	J
669	365	299	438	263	418	556	370	223	298



APPLICATION AREAS

-  WASTE WATER TREATMENT
-  MARINE
-  TEXTILE
-  MACHINE-AUTOMATION
-  PACKAGING
-  DEFENSE INDUSTRY
-  AUTOMOTIVE
-  PETROL AND OIL
-  FOOD INDUSTRY
-  CERAMIC INDUSTRY
-  PAINT INDUSTRY
-  MEDICAL INDUSTRY
-  MINING - ENERGY

ADVANTAGES

- 1) Solid particles may pass through the pump.
- 2) The pump is ex-proof. (Suitable for explosive and flammable fluids.)
- 3) Maintenance cost is low.
- 4) Liquid flow rate can also be adjusted when the air inlet pressure of the pump is adjusted.
- 5) The pump's air valve and pilot valve repair kits can be repaired without disassembling the pump.
- 6) It has the feature of working dry.
- 7) The suction depth of this pump is 6 m.

PUMP TECHNICAL SPECIFICATIONS

- Max. Capacity** : 890 l/min
- Fluid Inlet-Outlet** : 3"
- Max. Fluid Discharge** : 7 bar
- Body Material** : Aluminum, Casting, Stainless Steel
- Air Inlet Size** : 3/4"
- Solid Particle Size** : 8 mm
- Dry Suction Depth** : 6 m
- Max Air Pressure** : 7 bar
- Diaphragm Options** : Santoprene, Neoprene, Buna-N, EPDM, Teflon, Viton
- Ball Options** : Santoprene, Neoprene, Buna-N, EPDM, Teflon, Viton
- Ball Seat Options** : Santoprene, Neoprene, Buna-N, EPDM, Teflon, Viton



Ex h IIB T(80°C) Gb
Ex h IIIB T(80°C) Db
Ex h I M2 T(80°C) Mb

Note: The valve parts of the pumps are made of conductive polypropylene.

DIAPHRAGM PUMPS PERFORMANCE CURVES

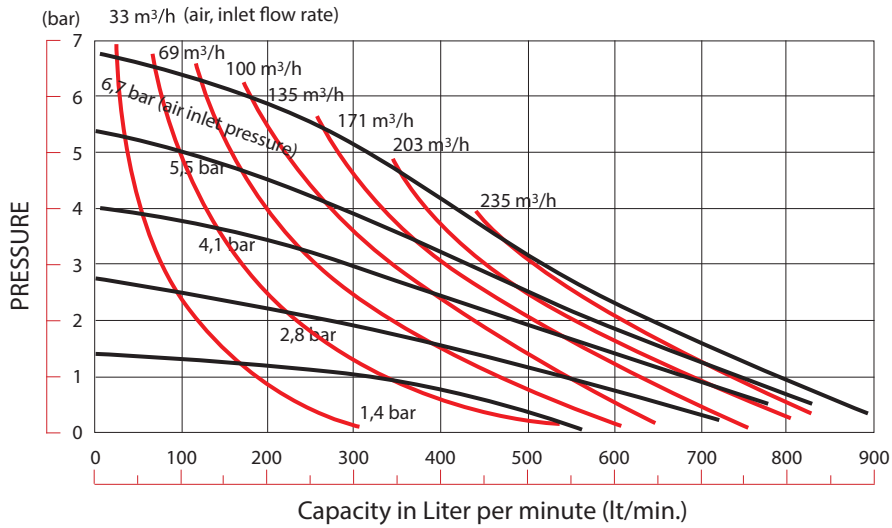

PUMP EXTERNAL DIMENSIONS

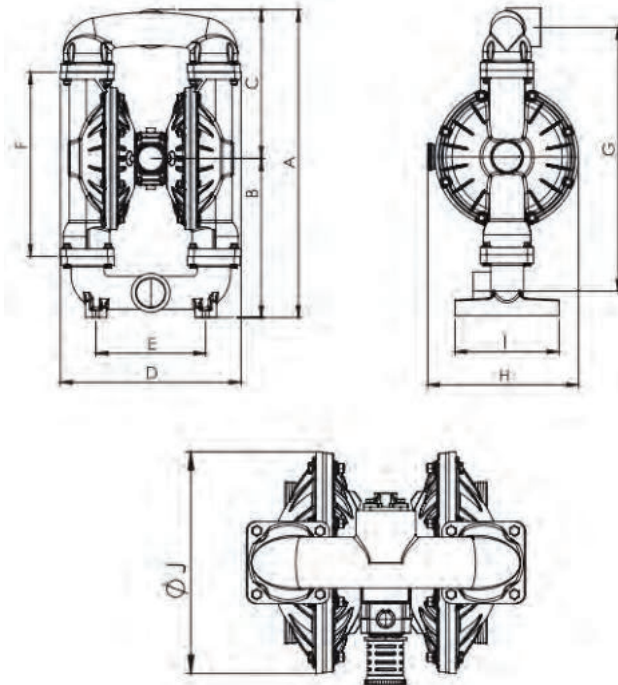

A	B	C	D	E	F	G	H	I	J
858	443	415	504	306	514	735	421	290	400

VP05 AL METALLIC BODY PUMP



APPLICATION AREAS

- WASTE WATER TREATMENT
- MINING - ENERGY
- TEXTILE
- MARINE
- PACKAGING
- MACHINE-AUTOMATION
- AUTOMOTIVE
- FOOD INDUSTRY
- PAINT INDUSTRY

ADVANTAGES

- 1) Solid particles may pass through the pump.
- 2) Maintenance cost is low.
- 3) Liquid flow rate can also be adjusted when the air inlet pressure of the pump is adjusted.
- 4) The pump's air valve and pilot valve repair kits can be repaired without disassembling the pump.
- 5) It has the feature of working dry.
- 6) The suction depth of this pump is 6 m.

PUMP TECHNICAL SPECIFICATIONS

- Max. Capacity** : 55 l/min
- Fluid Inlet-Outlet** : 3/4"
- Max. Fluid Discharge** : 7 bar
- Body Material** : Aluminum
- Air Inlet Size** : 1/4"
- Solid Particle Size** : 3 mm
- Dry Suction Depth** : 6 m
- Max Air Pressure** : 7 bar
- Diaphragm Options** : Santoprene, Neoprene, Buna-N, EPDM, Teflon, Viton
- Ball Options** : Santoprene, Neoprene, Buna-N, EPDM, Teflon, Viton
- Ball Seat Options** : Santoprene, Neoprene, Buna-N, EPDM, Teflon, Viton

DIAPHRAGM PUMPS PERFORMANCE CURVES

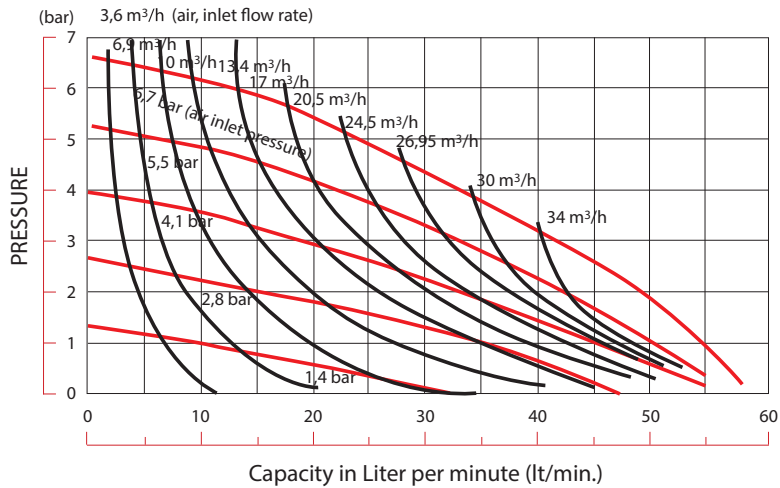

PUMP EXTERNAL DIMENSIONS

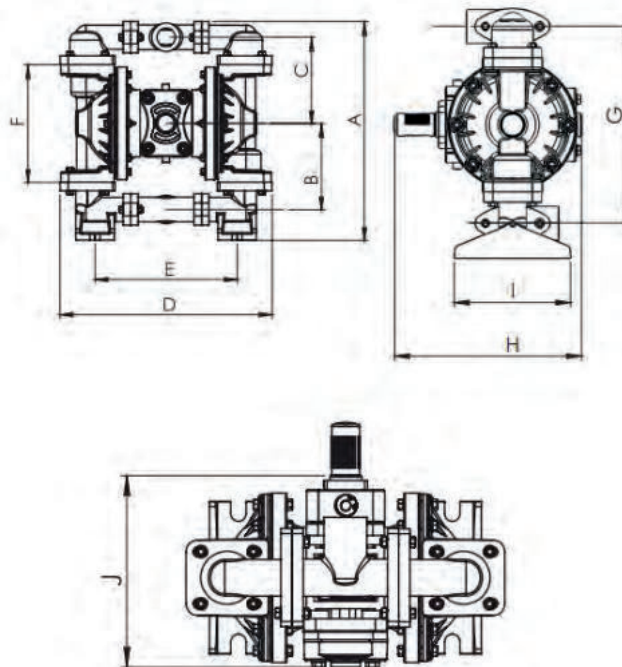

A	B	C	D	E	F	G	H	I	J
279	110	110	270	181	150	220	209	130	163



APPLICATION AREAS



- | | |
|---|--|
|  WASTE WATER TREATMENT |  MARINE |
|  TEXTILE |  MACHINE-AUTOMATION |
|  PACKAGING |  DEFENSE INDUSTRY |
|  AUTOMOTIVE |  PETROL AND OIL |
|  FOOD INDUSTRY |  CERAMIC INDUSTRY |
|  PAINT INDUSTRY |  MEDICAL INDUSTRY |
|  MINING - ENERGY | |

ADVANTAGES



- 1) Solid particles may pass through the pump.
- 2) Maintenance cost is low.
- 3) Liquid flow rate can also be adjusted when the air inlet pressure of the pump is adjusted.
- 4) The pump's air valve and pilot valve repair kits can be repaired without disassembling the pump.
- 5) It has the feature of working dry.
- 6) The suction depth of this pump is 6 m.

PUMP TECHNICAL SPECIFICATIONS



- | | |
|-----------------------------|---|
| Max. Capacity | : 150 l/min |
| Fluid Inlet-Outlet | : 1" |
| Max. Fluid Discharge | : 7 bar |
| Body Material | : Aluminum |
| Air Inlet Size | : ½" |
| Solid Particle Size | : 4 mm |
| Dry Suction Depth | : 6 m |
| Max Air Pressure | : 7 bar |
| Diaphragm Options | : Santoprene, Neoprene, Buna-N, EPDM, Teflon, Viton |
| Ball Options | : Santoprene, Neoprene, Buna-N, EPDM, Teflon, Viton |
| Ball Seat Options | : Santoprene, Neoprene, Buna-N, EPDM, Teflon, Viton |

DIAPHRAGM PUMPS PERFORMANCE CURVES

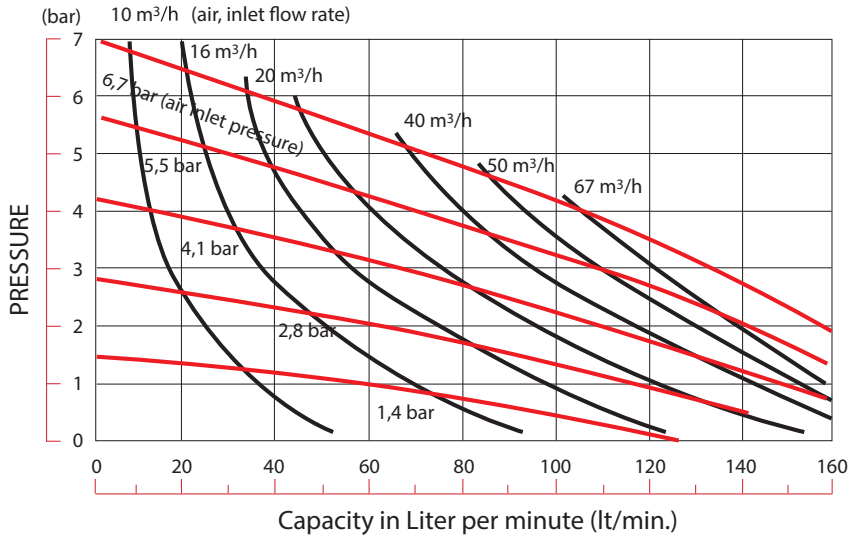

PUMP EXTERNAL DIMENSIONS

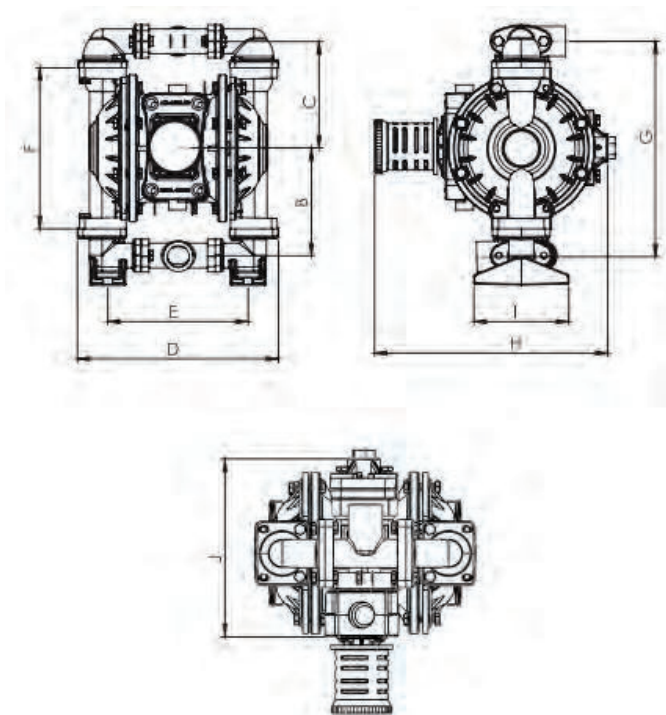

A	B	C	D	E	F	G	H	I	J
356	146	146	274	191	220	293	312	130	220



APPLICATION AREAS



- | | |
|---|--|
|  WASTE WATER TREATMENT |  MARINE |
|  TEXTILE |  MACHINE-AUTOMATION |
|  PACKAGING |  DEFENSE INDUSTRY |
|  AUTOMOTIVE |  PETROL AND OIL |
|  FOOD INDUSTRY |  CERAMIC INDUSTRY |
|  PAINT INDUSTRY |  MEDICAL INDUSTRY |
|  MINING - ENERGY | |

ADVANTAGES



- 1) Solid particles may pass through the pump.
- 2) Maintenance cost is low.
- 3) Liquid flow rate can also be adjusted when the air inlet pressure of the pump is adjusted.
- 4) The pump's air valve and pilot valve repair kits can be repaired without disassembling the pump.
- 5) It has the feature of working dry.
- 6) The suction depth of this pump is 6 m.

PUMP TECHNICAL SPECIFICATIONS



- | | |
|-----------------------------|---|
| Max. Capacity | : 400 l/min |
| Fluid Inlet-Outlet | : 1½" |
| Max. Fluid Discharge | : 7 bar |
| Body Material | : Aluminum |
| Air Inlet Size | : 3/4" |
| Solid Particle Size | : 6 mm |
| Dry Suction Depth | : 6 m |
| Max Air Pressure | : 7 bar |
| Diaphragm Options | : Santoprene, Neoprene, Buna-N, EPDM, Teflon, Viton |
| Ball Options | : Santoprene, Neoprene, Buna-N, EPDM, Teflon, Viton |
| Ball Seat Options | : Santoprene, Neoprene, Buna-N, EPDM, Teflon, Viton |

DIAPHRAGM PUMPS PERFORMANCE CURVES

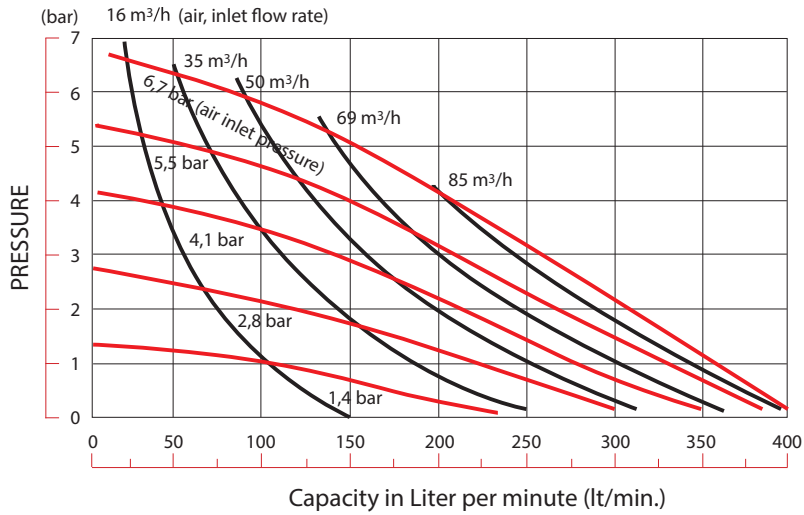

PUMP EXTERNAL DIMENSIONS

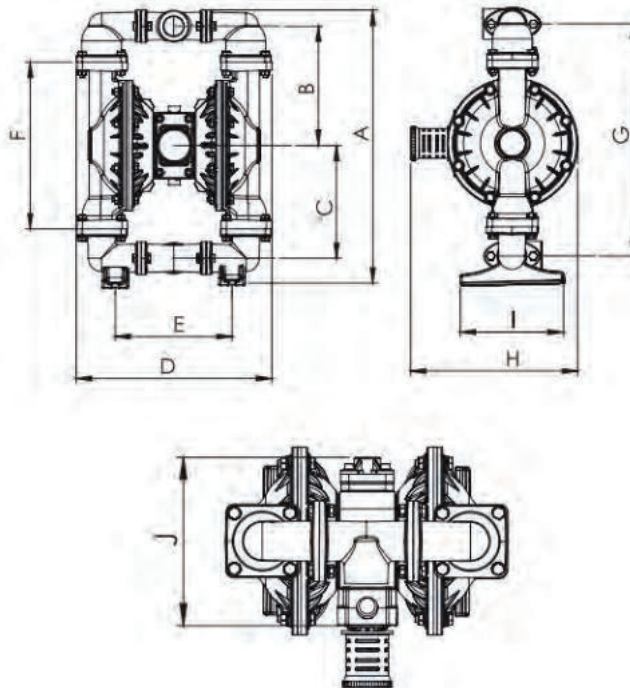

A	B	C	D	E	F	G	H	I	J
605	260	245	425	253	363	505	363	224	253

VP20 AL METALLIC BODY PUMP



APPLICATION AREAS

- WASTE WATER TREATMENT
- TEXTILE
- PACKAGING
- AUTOMOTIVE
- FOOD INDUSTRY
- PAINT INDUSTRY
- MINING - ENERGY
- MARINE
- MACHINE-AUTOMATION
- DEFENSE INDUSTRY
- PETROL AND OIL
- CERAMIC INDUSTRY
- MEDICAL INDUSTRY

ADVANTAGES

- 1) Solid particles may pass through the pump.
- 2) Maintenance cost is low.
- 3) Liquid flow rate can also be adjusted when the air inlet pressure of the pump is adjusted.
- 4) The pump's air valve and pilot valve repair kits can be repaired without disassembling the pump.
- 5) It has the feature of working dry.
- 6) The suction depth of this pump is 6 m.

PUMP TECHNICAL SPECIFICATIONS

- Max. Capacity** : 560 l/min
- Fluid Inlet-Outlet** : 2"
- Max. Fluid Discharge** : 7 bar
- Body Material** : Aluminum
- Air Inlet Size** : 3/4"
- Solid Particle Size** : 6 mm
- Dry Suction Depth** : 6 m
- Max Air Pressure** : 7 bar
- Diaphragm Options** : Santoprene, Neoprene, Buna-N, EPDM, Teflon, Viton
- Ball Options** : Santoprene, Neoprene, Buna-N, EPDM, Teflon, Viton
- Ball Seat Options** : Santoprene, Neoprene, Buna-N, EPDM, Teflon, Viton

DIAPHRAGM PUMPS PERFORMANCE CURVES

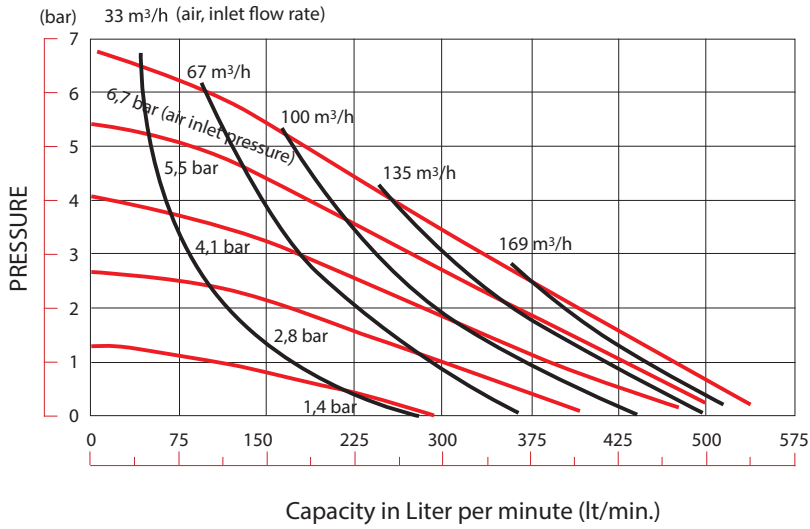

PUMP EXTERNAL DIMENSIONS

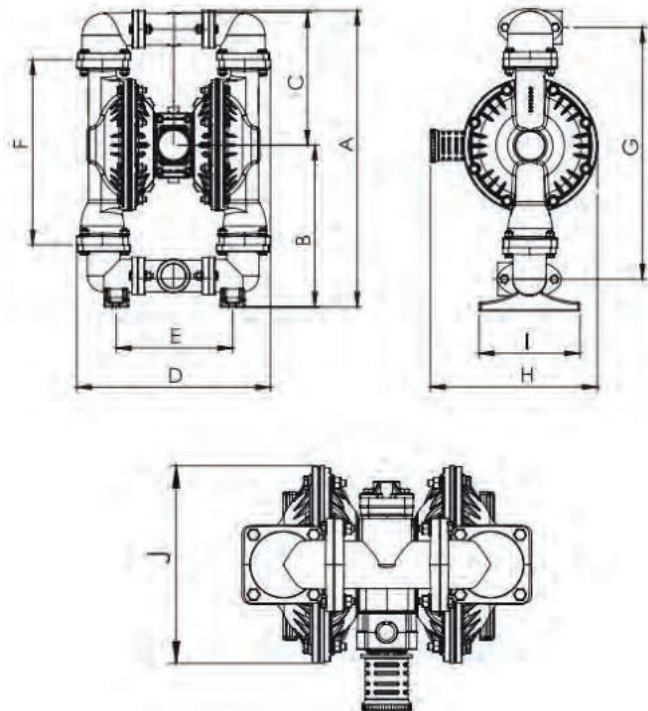

A	B	C	D	E	F	G	H	I	J
669	365	299	438	263	418	556	370	223	298

VP30 AL METALLIC BODY PUMP



APPLICATION AREAS



- | | |
|---|--|
|  WASTE WATER TREATMENT |  MARINE |
|  TEXTILE |  MACHINE-AUTOMATION |
|  PACKAGING |  DEFENSE INDUSTRY |
|  AUTOMOTIVE |  PETROL AND OIL |
|  FOOD INDUSTRY |  CERAMIC INDUSTRY |
|  PAINT INDUSTRY |  MEDICAL INDUSTRY |
|  MINING - ENERGY | |

ADVANTAGES



- 1) Solid particles may pass through the pump.
- 2) Maintenance cost is low.
- 3) Liquid flow rate can also be adjusted when the air inlet pressure of the pump is adjusted.
- 4) The pump's air valve and pilot valve repair kits can be repaired without disassembling the pump.
- 5) It has the feature of working dry.
- 6) The suction depth of this pump is 6 m.

PUMP TECHNICAL SPECIFICATIONS



- | | |
|-----------------------------|---|
| Max. Capacity | : 890 l/min |
| Fluid Inlet-Outlet | : 3" |
| Max. Fluid Discharge | : 7 bar |
| Body Material | : Aluminum, Cast Iron, Stainless Steel |
| Air Inlet Size | : 3/4" |
| Solid Particle Size | : 8 mm |
| Dry Suction Depth | : 6 m |
| Max Air Pressure | : 7 bar |
| Diaphragm Options | : Santoprene, Neoprene, Buna-N, EPDM, Teflon, Viton |
| Ball Options | : Santoprene, Neoprene, Buna-N, EPDM, Teflon, Viton |
| Ball Seat Options | : Santoprene, Neoprene, Buna-N, EPDM, Teflon, Viton |

DIAPHRAGM PUMPS PERFORMANCE CURVES

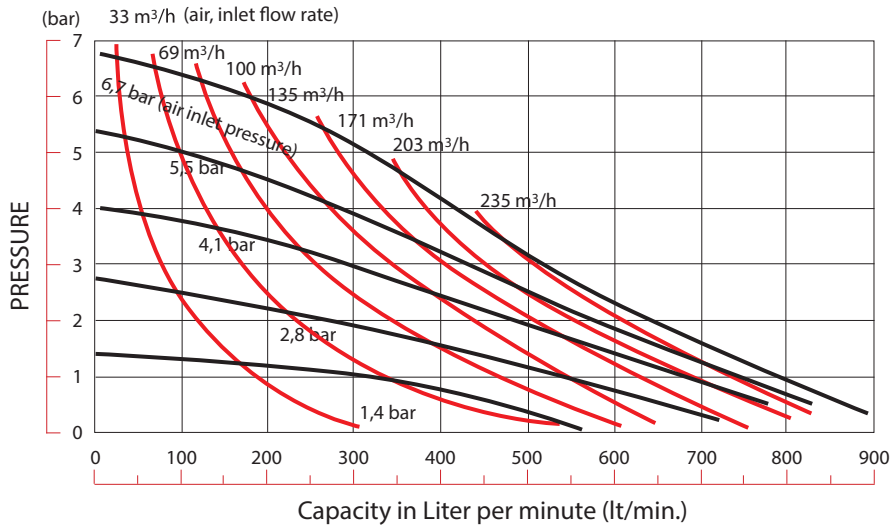

PUMP EXTERNAL DIMENSIONS

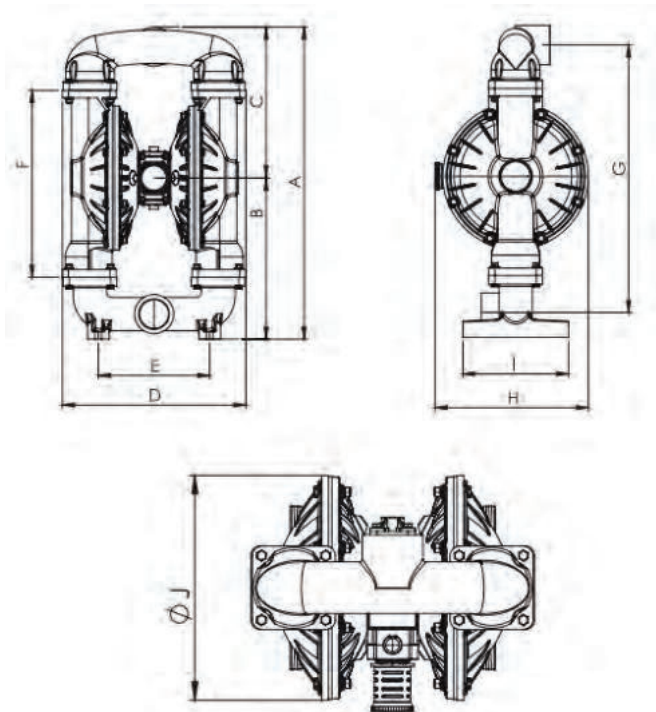

A	B	C	D	E	F	G	H	I	J
858	443	415	504	306	514	735	421	290	400

VPO5 METALLIC BODY PUMP (SIDED INLET/OUTLET)



APPLICATION AREAS

- WASTE WATER TREATMENT
- TEXTILE
- PACKAGING
- AUTOMOTIVE
- FOOD INDUSTRY
- PAINT INDUSTRY
- MINING - ENERGY
- MARINE
- MACHINE-AUTOMATION

ADVANTAGES

- 1) Solid particles may pass through the pump.
- 2) Maintenance cost is low.
- 3) Liquid flow rate can also be adjusted when the air inlet pressure of the pump is adjusted.
- 4) The pump's air valve and pilot valve repair kits can be repaired without disassembling the pump.
- 5) It has the feature of working dry.
- 6) The suction depth of this pump is 6 m.

PUMP TECHNICAL SPECIFICATIONS

- Max. Capacity** : 55 l/min
- Fluid Inlet-Outlet** : 3/4"
- Max. Fluid Discharge** : 7 bar
- Body Material** : Aluminum
- Air Inlet Size** : 1/4"
- Solid Particle Size** : 3 mm
- Dry Suction Depth** : 6 m
- Max Air Pressure** : 7 bar
- Diaphragm Options** : Santoprene, Neoprene, Buna-N, EPDM, Teflon, Viton
- Ball Options** : Santoprene, Neoprene, Buna-N, EPDM, Teflon, Viton
- Ball Seat Options** : Santoprene, Neoprene, Buna-N, EPDM, Teflon, Viton

DIAPHRAGM PUMPS PERFORMANCE CURVES

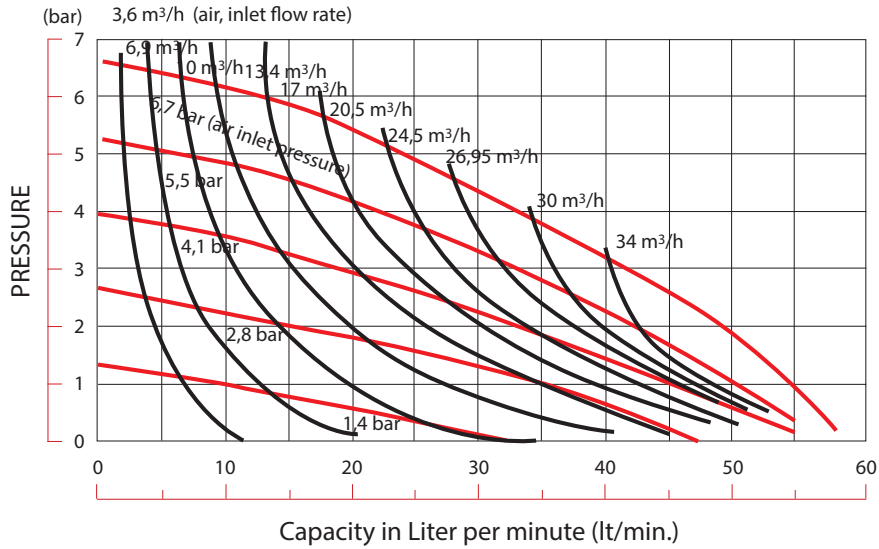

PUMP EXTERNAL DIMENSIONS

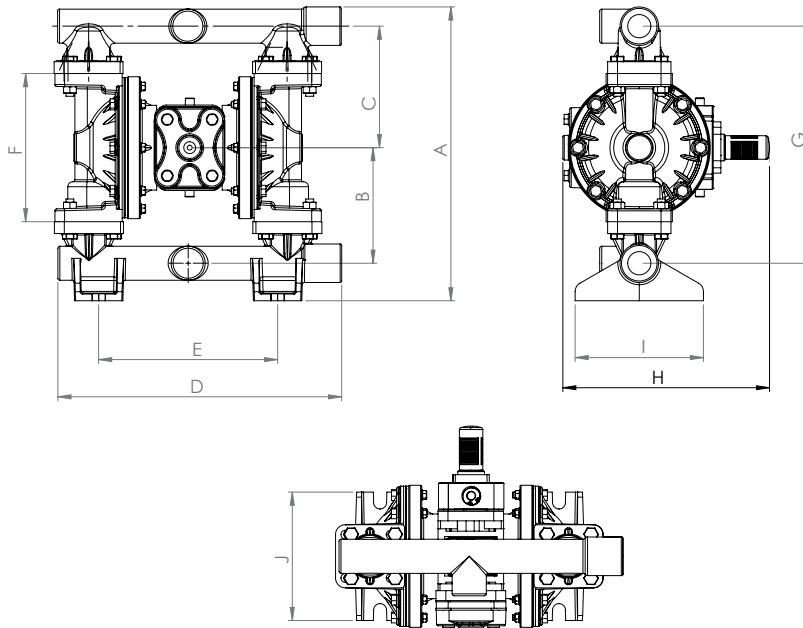

A	B	C	D	E	F	G	H	I	J
298	117	113	287	181	150	240	209	130	130

VP10 METALLIC BODY PUMP (SIDED INLET/OUTLET)



APPLICATION AREAS



- WASTE WATER TREATMENT
- TEXTILE
- PACKAGING
- AUTOMOTIVE
- FOOD INDUSTRY
- PAINT INDUSTRY
- MINING - ENERGY
- MARINE
- MACHINE-AUTOMATION
- DEFENSE INDUSTRY
- PETROL AND OIL
- CERAMIC INDUSTRY
- MEDICAL INDUSTRY

ADVANTAGES



- 1) Solid particles may pass through the pump.
- 2) Maintenance cost is low.
- 3) Liquid flow rate can also be adjusted when the air inlet pressure of the pump is adjusted.
- 4) The pump's air valve and pilot valve repair kits can be repaired without disassembling the pump.
- 5) It has the feature of working dry.
- 6) The suction depth of this pump is 6 m.

PUMP TECHNICAL SPECIFICATIONS



- Max. Capacity** : 150 l/min
- Fluid Inlet-Outlet** : 1"
- Max. Fluid Discharge** : 7 bar
- Body Material** : Aluminum
- Air Inlet Size** : ½"
- Solid Particle Size** : 4 mm
- Dry Suction Depth** : 6 m
- Max Air Pressure** : 7 bar
- Diaphragm Options** : Santoprene, Neoprene, Buna-N, EPDM, Teflon, Viton
- Ball Options** : Santoprene, Neoprene, Buna-N, EPDM, Teflon, Viton
- Ball Seat Options** : Santoprene, Neoprene, Buna-N, EPDM, Teflon, Viton

DIAPHRAGM PUMPS PERFORMANCE CURVES

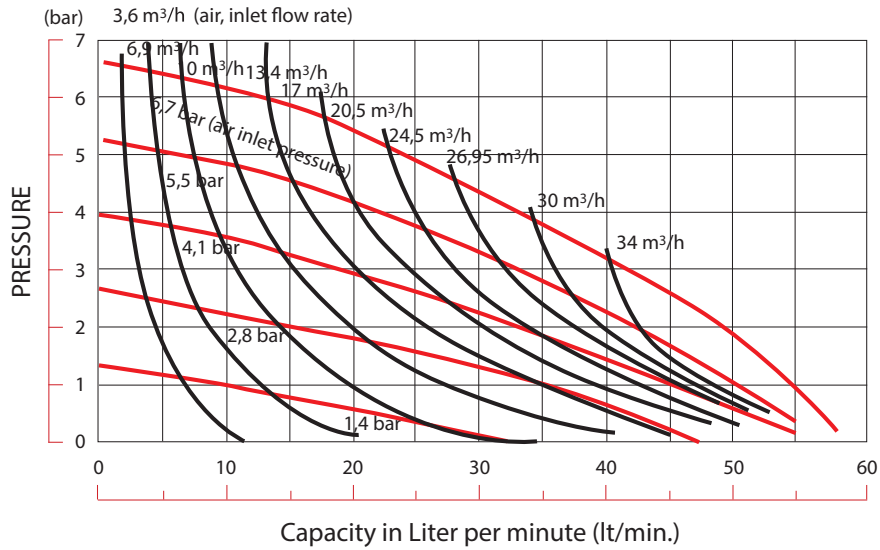

PUMP EXTERNAL DIMENSIONS

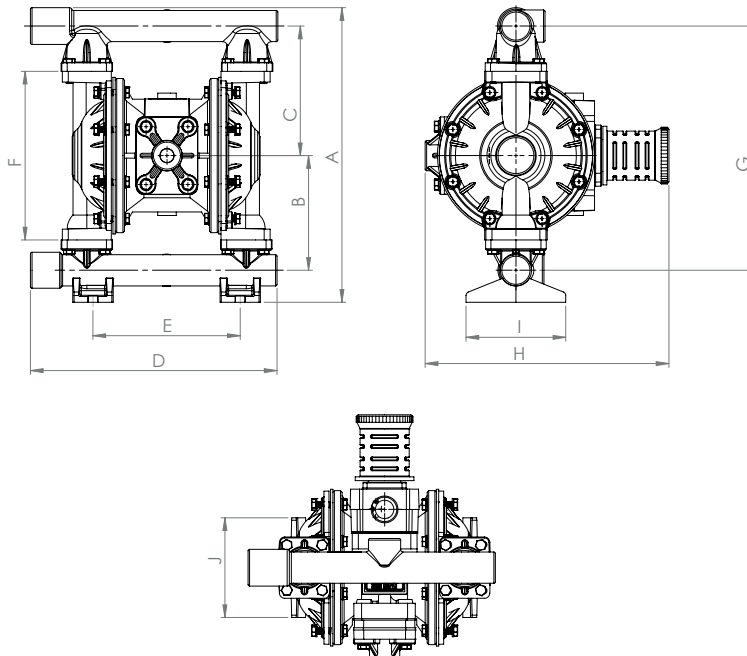

A	B	C	D	E	F	G	H	I	J
384	150	169	321	192	220	318	318	130	130



APPLICATION AREAS



- | | |
|---|--|
|  WASTE WATER TREATMENT |  MARINE |
|  TEXTILE |  MACHINE-AUTOMATION |
|  PACKAGING |  DEFENSE INDUSTRY |
|  AUTOMOTIVE |  PETROL AND OIL |
|  FOOD INDUSTRY |  CERAMIC INDUSTRY |
|  PAINT INDUSTRY |  MEDICAL INDUSTRY |
|  MINING - ENERGY | |

ADVANTAGES

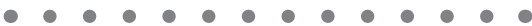

- 1) Solid particles may pass through the pump.
- 2) Maintenance cost is low.
- 3) Liquid flow rate can also be adjusted when the air inlet pressure of the pump is adjusted.
- 4) The pump's air valve and pilot valve repair kits can be repaired without disassembling the pump.
- 5) It has the feature of working dry.
- 6) The suction depth of this pump is 6 m.

PUMP TECHNICAL SPECIFICATIONS



- | | |
|-----------------------------|---|
| Max. Capacity | : 150 l/min |
| Fluid Inlet-Outlet | : 1" |
| Max. Fluid Discharge | : 7 bar |
| Body Material | : Cast Iron |
| Air Inlet Size | : ½" |
| Solid Particle Size | : 4 mm |
| Dry Suction Depth | : 6 m |
| Max Air Pressure | : 7 bar |
| Diaphragm Options | : Santoprene, Neoprene, Buna-N, EPDM, Teflon, Viton |
| Ball Options | : Santoprene, Neoprene, Buna-N, EPDM, Teflon, Viton |
| Ball Seat Options | : Santoprene, Neoprene, Buna-N, EPDM, Teflon, Viton |

DIAPHRAGM PUMPS PERFORMANCE CURVES

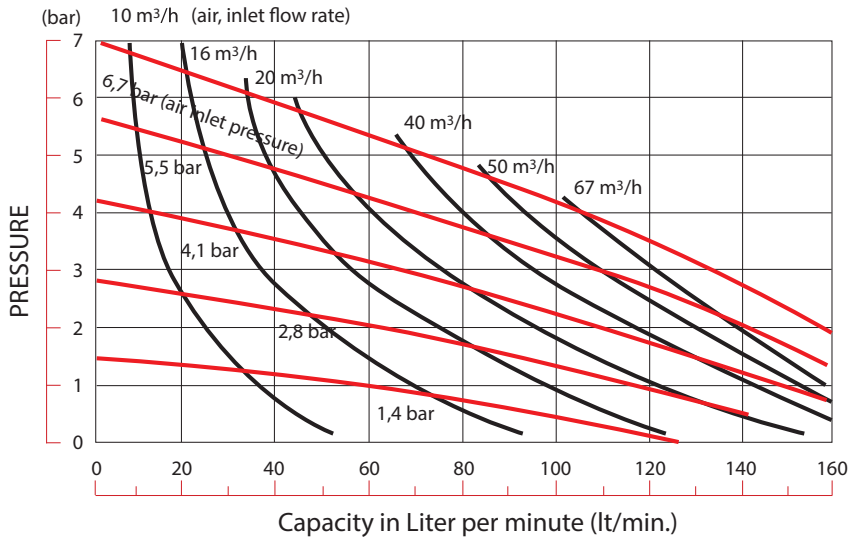

PUMP EXTERNAL DIMENSIONS

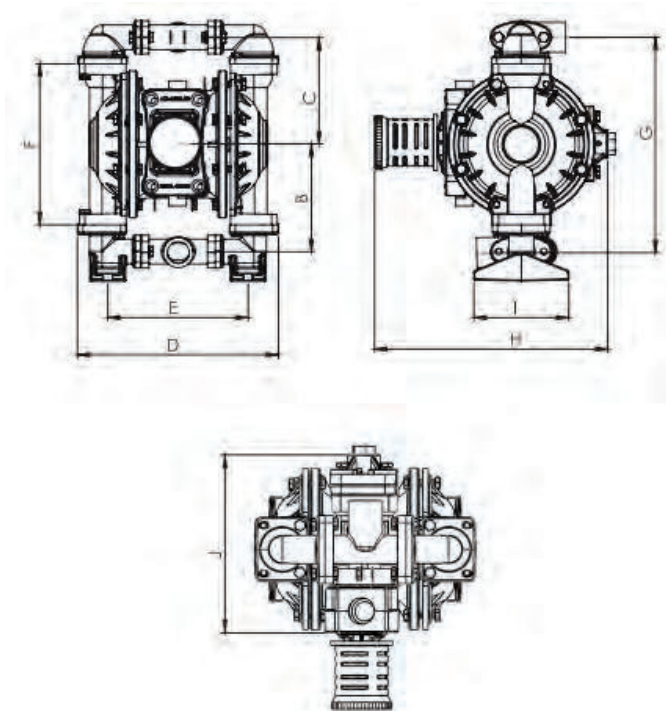

A	B	C	D	E	F	G	H	I	J
356	146	146	274	191	220	293	312	130	220



APPLICATION AREAS

- WASTE WATER TREATMENT
- MARINE
- TEXTILE
- MACHINE-AUTOMATION
- PACKAGING
- DEFENSE INDUSTRY
- AUTOMOTIVE
- PETROL AND OIL
- FOOD INDUSTRY
- CERAMIC INDUSTRY
- PAINT INDUSTRY
- MEDICAL INDUSTRY
- MINING - ENERGY

ADVANTAGES

- 1) Solid particles may pass through the pump.
- 2) Maintenance cost is low.
- 3) Liquid flow rate can also be adjusted when the air inlet pressure of the pump is adjusted.
- 4) The pump's air valve and pilot valve repair kits can be repaired without disassembling the pump.
- 5) It has the feature of working dry.
- 6) The suction depth of this pump is 6 m.

PUMP TECHNICAL SPECIFICATIONS

- Max. Capacity** : 400 l/min
- Fluid Inlet-Outlet** : 1½"
- Max. Fluid Discharge** : 7 bar
- Body Material** : Cast Iron
- Air Inlet Size** : 3/4"
- Solid Particle Size** : 6 mm
- Dry Suction Depth** : 6 m
- Max Air Pressure** : 7 bar
- Diaphragm Options** : Santoprene, Neoprene, Buna-N, EPDM, Teflon, Viton
- Ball Options** : Santoprene, Neoprene, Buna-N, EPDM, Teflon, Viton
- Ball Seat Options** : Santoprene, Neoprene, Buna-N, EPDM, Teflon, Viton

DIAPHRAGM PUMPS PERFORMANCE CURVES

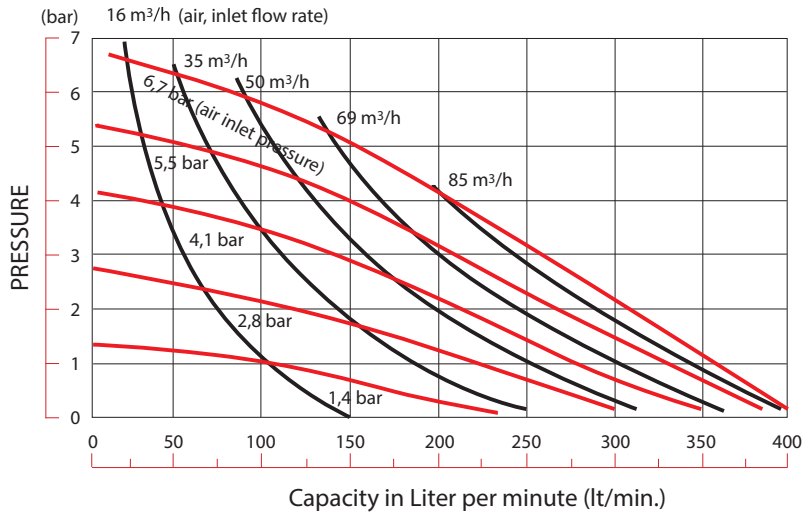

PUMP EXTERNAL DIMENSIONS

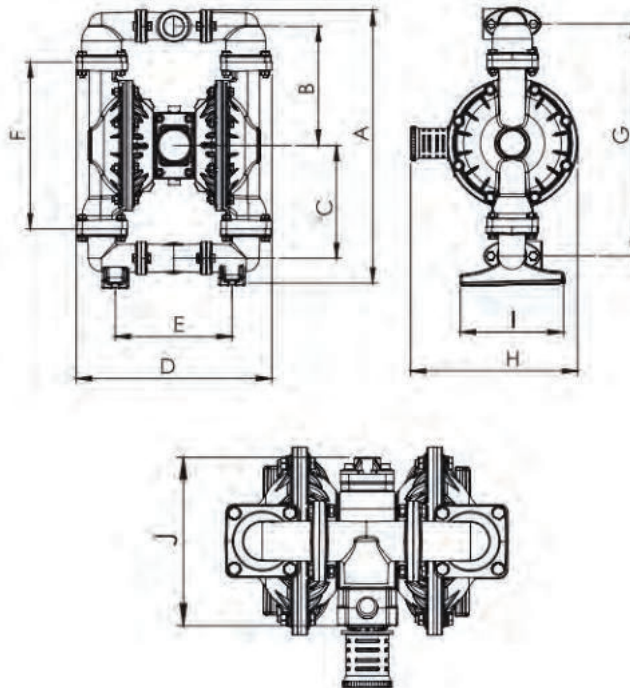

A	B	C	D	E	F	G	H	I	J
605	260	245	425	253	363	505	363	224	253



APPLICATION AREAS



- | | |
|---|--|
|  WASTE WATER TREATMENT |  MARINE |
|  TEXTILE |  MACHINE-AUTOMATION |
|  PACKAGING |  DEFENSE INDUSTRY |
|  AUTOMOTIVE |  PETROL AND OIL |
|  FOOD INDUSTRY |  CERAMIC INDUSTRY |
|  PAINT INDUSTRY |  MEDICAL INDUSTRY |
|  MINING - ENERGY | |

ADVANTAGES



- 1) Solid particles may pass through the pump.
- 2) Maintenance cost is low.
- 3) Liquid flow rate can also be adjusted when the air inlet pressure of the pump is adjusted.
- 4) The pump's air valve and pilot valve repair kits can be repaired without disassembling the pump.
- 5) It has the feature of working dry.
- 6) The suction depth of this pump is 6 m.

PUMP TECHNICAL SPECIFICATIONS



- | | |
|-----------------------------|---|
| Max. Capacity | : 560 l/min |
| Fluid Inlet-Outlet | : 2" |
| Max. Fluid Discharge | : 7 bar |
| Body Material | : Cast Iron |
| Air Inlet Size | : 3/4" |
| Solid Particle Size | : 6 mm |
| Dry Suction Depth | : 6 m |
| Max Air Pressure | : 7 bar |
| Diaphragm Options | : Santoprene, Neoprene, Buna-N, EPDM, Teflon, Viton |
| Ball Options | : Santoprene, Neoprene, Buna-N, EPDM, Teflon, Viton |
| Ball Seat Options | : Santoprene, Neoprene, Buna-N, EPDM, Teflon, Viton |

DIAPHRAGM PUMPS PERFORMANCE CURVES

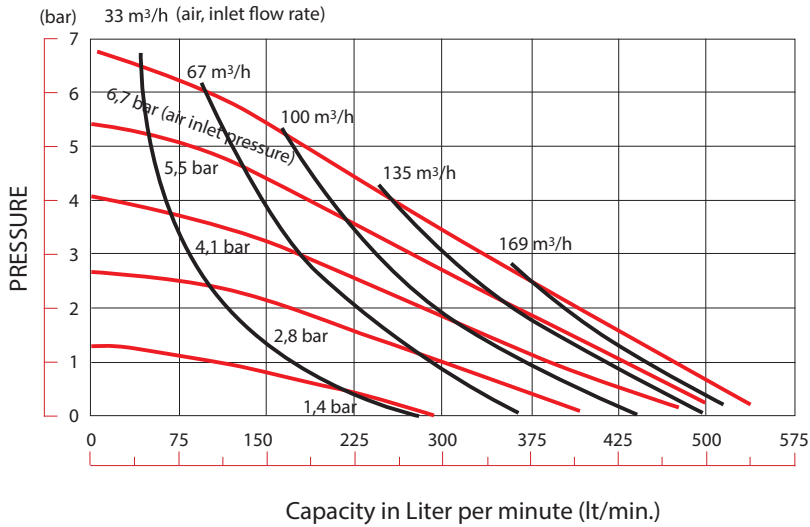

PUMP EXTERNAL DIMENSIONS

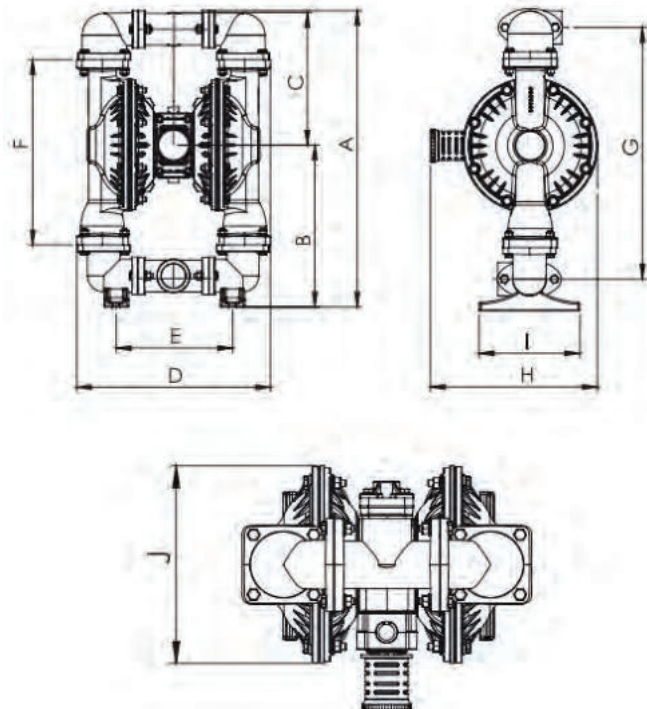

A	B	C	D	E	F	G	H	I	J
669	365	299	438	263	418	556	370	223	298



APPLICATION AREAS



- | | |
|---|--|
|  WASTE WATER TREATMENT |  MARINE |
|  TEXTILE |  MACHINE-AUTOMATION |
|  PACKAGING |  DEFENSE INDUSTRY |
|  AUTOMOTIVE |  PETROL AND OIL |
|  FOOD INDUSTRY |  CERAMIC INDUSTRY |
|  PAINT INDUSTRY |  MEDICAL INDUSTRY |
|  MINING - ENERGY | |

ADVANTAGES



- 1) Solid particles may pass through the pump.
- 2) Maintenance cost is low.
- 3) Liquid flow rate can also be adjusted when the air inlet pressure of the pump is adjusted.
- 4) The pump's air valve and pilot valve repair kits can be repaired without disassembling the pump.
- 5) It has the feature of working dry.
- 6) The suction depth of this pump is 6 m.

PUMP TECHNICAL SPECIFICATIONS



- | | |
|-----------------------------|---|
| Max. Capacity | : 890 l/min |
| Fluid Inlet-Outlet | : 3" |
| Max. Fluid Discharge | : 7 bar |
| Body Material | : Cast Iron |
| Air Inlet Size | : 3/4" |
| Solid Particle Size | : 8 mm |
| Dry Suction Depth | : 6 m |
| Max Air Pressure | : 7 bar |
| Diaphragm Options | : Santoprene, Neoprene, Buna-N, EPDM, Teflon, Viton |
| Ball Options | : Santoprene, Neoprene, Buna-N, EPDM, Teflon, Viton |
| Ball Seat Options | : Santoprene, Neoprene, Buna-N, EPDM, Teflon, Viton |

DIAPHRAGM PUMPS PERFORMANCE CURVES

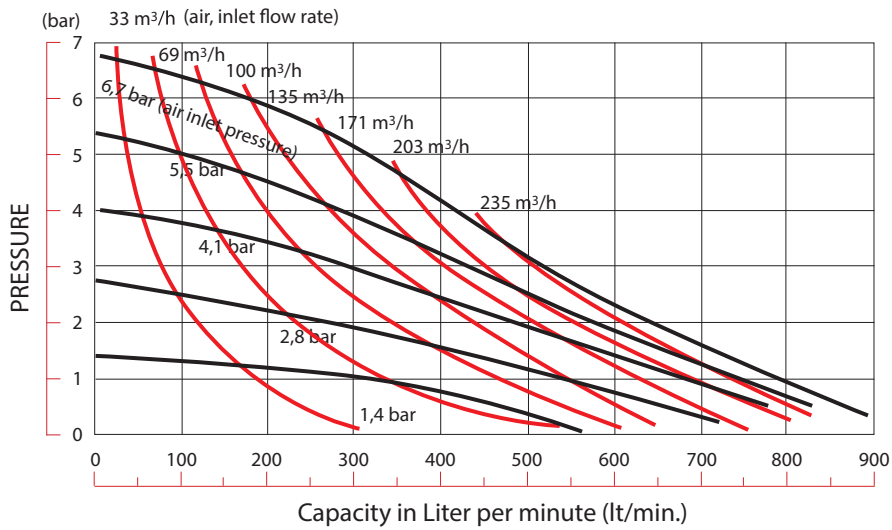

PUMP EXTERNAL DIMENSIONS

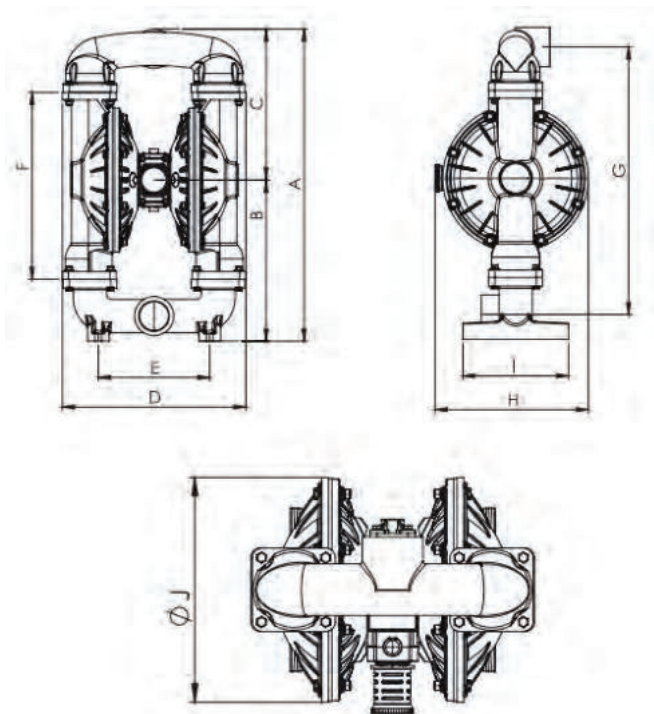

A	B	C	D	E	F	G	H	I	J
858	443	415	504	306	514	735	421	290	400



APPLICATION AREAS



- WASTE WATER TREATMENT
- TEXTILE
- PACKAGING
- AUTOMOTIVE
- FOOD INDUSTRY
- PAINT INDUSTRY
- Mining - Energy
- MARINE
- MACHINE-AUTOMATION
- DEFENSE INDUSTRY
- PETROL AND OIL
- CERAMIC INDUSTRY
- MEDICAL INDUSTRY

ADVANTAGES



- 1) Solid particles may pass through the pump.
- 2) Maintenance cost is low.
- 3) Liquid flow rate can also be adjusted when the air inlet pressure of the pump is adjusted.
- 4) The pump's air valve and pilot valve repair kits can be repaired without disassembling the pump.
- 5) It has the feature of working dry.
- 6) The suction depth of this pump is 6 m.

PUMP TECHNICAL SPECIFICATIONS



- Max. Capacity** : 150 l/min
- Fluid Inlet-Outlet** : 1"
- Max. Fluid Discharge** : 7 bar
- Body Material** : Stainless Steel
- Air Inlet Size** : ½"
- Solid Particle Size** : 4 mm
- Dry Suction Depth** : 6 m
- Max Air Pressure** : 7 bar
- Diaphragm Options** : Santoprene, Neoprene, Buna-N, EPDM, Teflon, Viton
- Ball Options** : Santoprene, Neoprene, Buna-N, EPDM, Teflon, Viton
- Ball Seat Options** : Santoprene, Neoprene, Buna-N, EPDM, Teflon, Viton

DIAPHRAGM PUMPS PERFORMANCE CURVES

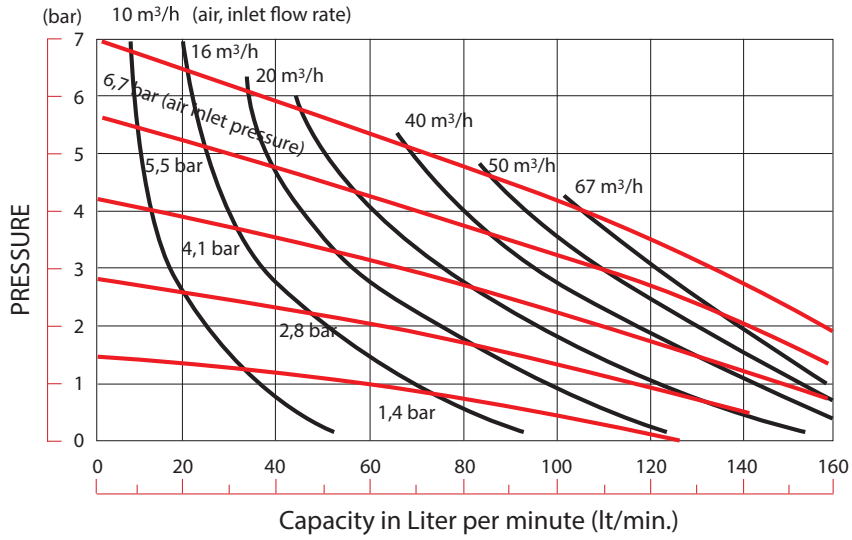

PUMP EXTERNAL DIMENSIONS

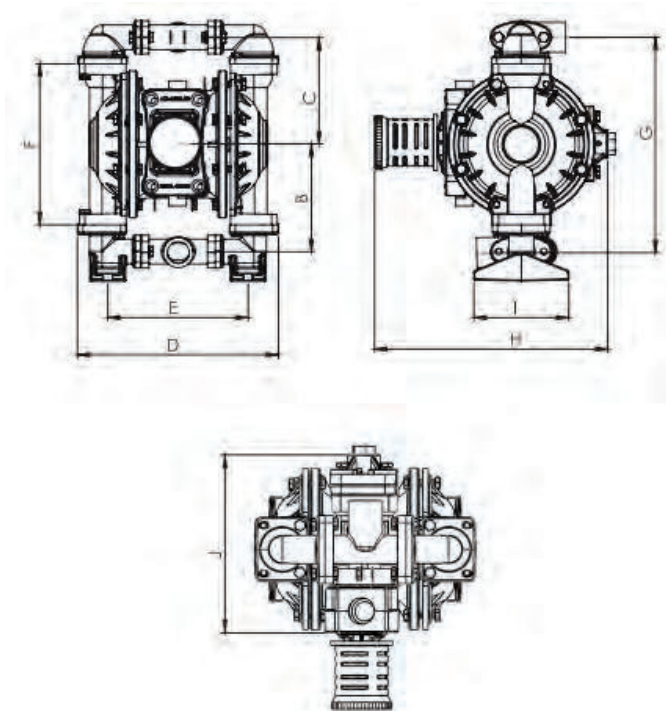

A	B	C	D	E	F	G	H	I	J
356	146	146	274	191	220	293	312	130	220



APPLICATION AREAS

- WASTE WATER TREATMENT
- TEXTILE
- PACKAGING
- AUTOMOTIVE
- FOOD INDUSTRY
- PAINT INDUSTRY
- MINING - ENERGY
- MARINE
- MACHINE-AUTOMATION
- DEFENSE INDUSTRY
- PETROL AND OIL
- CERAMIC INDUSTRY
- MEDICAL INDUSTRY

ADVANTAGES

- 1) Solid particles may pass through the pump.
- 2) Maintenance cost is low.
- 3) Liquid flow rate can also be adjusted when the air inlet pressure of the pump is adjusted.
- 4) The pump's air valve and pilot valve repair kits can be repaired without disassembling the pump.
- 5) It has the feature of working dry.
- 6) The suction depth of this pump is 6 m.

PUMP TECHNICAL SPECIFICATIONS

- Max. Capacity** : 400 l/min
- Fluid Inlet-Outlet** : 1½"
- Max. Fluid Discharge** : 7 bar
- Body Material** : Stainless Steel
- Air Inlet Size** : 3/4"
- Solid Particle Size** : 6 mm
- Dry Suction Depth** : 6 m
- Max Air Pressure** : 7 bar
- Diaphragm Options** : Santoprene, Neoprene, Buna-N, EPDM, Teflon, Viton
- Ball Options** : Santoprene, Neoprene, Buna-N, EPDM, Teflon, Viton
- Ball Seat Options** : Santoprene, Neoprene, Buna-N, EPDM, Teflon, Viton

DIAPHRAGM PUMPS PERFORMANCE CURVES

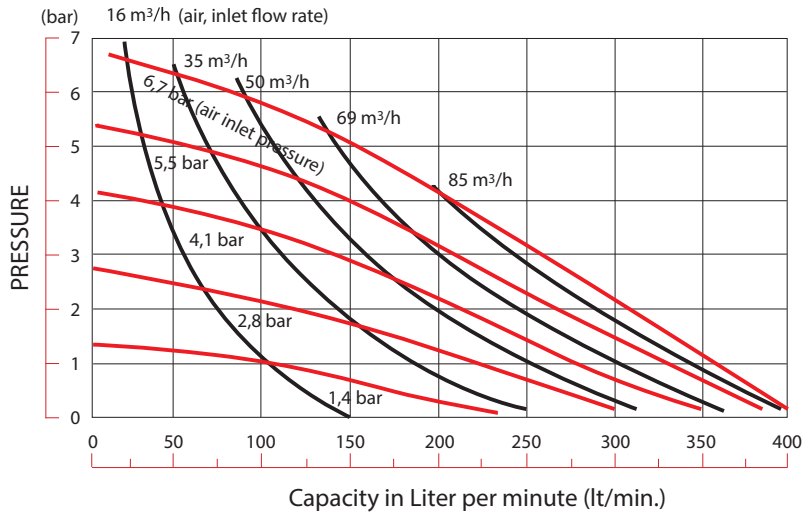

PUMP EXTERNAL DIMENSIONS

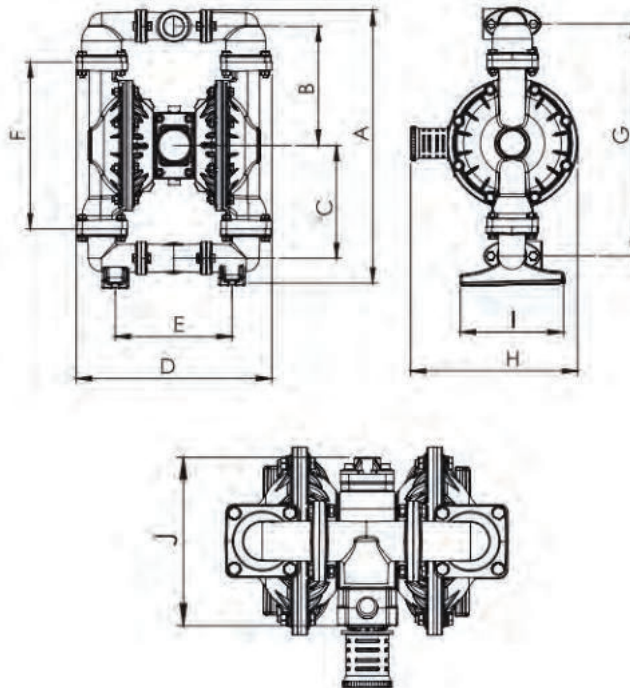

A	B	C	D	E	F	G	H	I	J
605	260	245	425	253	363	505	363	224	253



APPLICATION AREAS

- WASTE WATER TREATMENT
- TEXTILE
- PACKAGING
- AUTOMOTIVE
- FOOD INDUSTRY
- PAINT INDUSTRY
- MINING - ENERGY
- MARINE
- MACHINE-AUTOMATION
- DEFENSE INDUSTRY
- PETROL AND OIL
- CERAMIC INDUSTRY
- MEDICAL INDUSTRY

ADVANTAGES

- 1) Solid particles may pass through the pump.
- 2) Maintenance cost is low.
- 3) Liquid flow rate can also be adjusted when the air inlet pressure of the pump is adjusted.
- 4) The pump's air valve and pilot valve repair kits can be repaired without disassembling the pump.
- 5) It has the feature of working dry.
- 6) The suction depth of this pump is 6 m.

PUMP TECHNICAL SPECIFICATIONS

- Max. Capacity** : 560 l/min
- Fluid Inlet-Outlet** : 2"
- Max. Fluid Discharge** : 7 bar
- Body Material** : Stainless Steel
- Air Inlet Size** : 3/4"
- Solid Particle Size** : 6 mm
- Dry Suction Depth** : 6 m
- Max Air Pressure** : 7 bar
- Diaphragm Options** : Santoprene, Neoprene, Buna-N, EPDM, Teflon, Viton
- Ball Options** : Santoprene, Neoprene, Buna-N, EPDM, Teflon, Viton
- Ball Seat Options** : Santoprene, Neoprene, Buna-N, EPDM, Teflon, Viton

DIAPHRAGM PUMPS PERFORMANCE CURVES

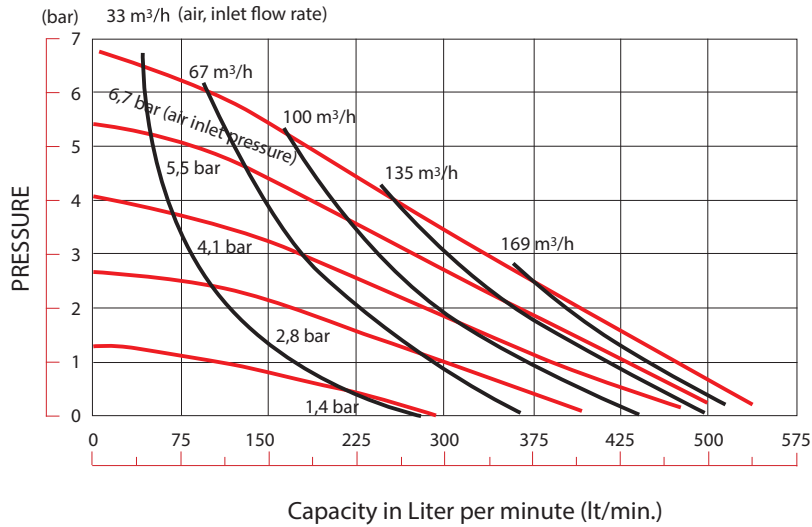

PUMP EXTERNAL DIMENSIONS

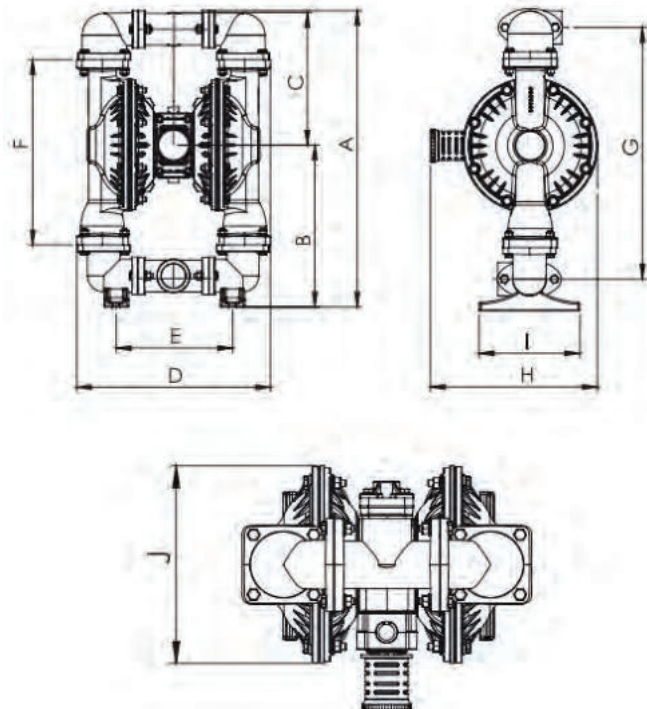

A	B	C	D	E	F	G	H	I	J
669	365	299	438	263	418	556	370	223	298

VP30 STAINLESS BODY PUMP



ADVANTAGES

- 1) Solid particles may pass through the pump.
- 2) Maintenance cost is low.
- 3) Liquid flow rate can also be adjusted when the air inlet pressure of the pump is adjusted.
- 4) The pump's air valve and pilot valve repair kits can be repaired without disassembling the pump.
- 5) It has the feature of working dry.
- 6) The suction depth of this pump is 6 m.

APPLICATION AREAS



- | | |
|---|--|
|  WASTE WATER TREATMENT |  MARINE |
|  TEXTILE |  MACHINE-AUTOMATION |
|  PACKAGING |  DEFENSE INDUSTRY |
|  AUTOMOTIVE |  PETROL AND OIL |
|  FOOD INDUSTRY |  CERAMIC INDUSTRY |
|  PAINT INDUSTRY |  MEDICAL INDUSTRY |
|  MINING - ENERGY | |

PUMP TECHNICAL SPECIFICATIONS



- | | |
|-----------------------------|---|
| Max. Capacity | : 890 l/min |
| Fluid Inlet-Outlet | : 3" |
| Max. Fluid Discharge | : 7 bar |
| Body Material | : Stainless Steel |
| Air Inlet Size | : 3/4" |
| Solid Particle Size | : 8 mm |
| Dry Suction Depth | : 6 m |
| Max Air Pressure | : 7 bar |
| Diaphragm Options | : Santoprene, Neoprene, Buna-N, EPDM, Teflon, Viton |
| Ball Options | : Santoprene, Neoprene, Buna-N, EPDM, Teflon, Viton |
| Ball Seat Options | : Santoprene, Neoprene, Buna-N, EPDM, Teflon, Viton |

DIAPHRAGM PUMPS PERFORMANCE CURVES

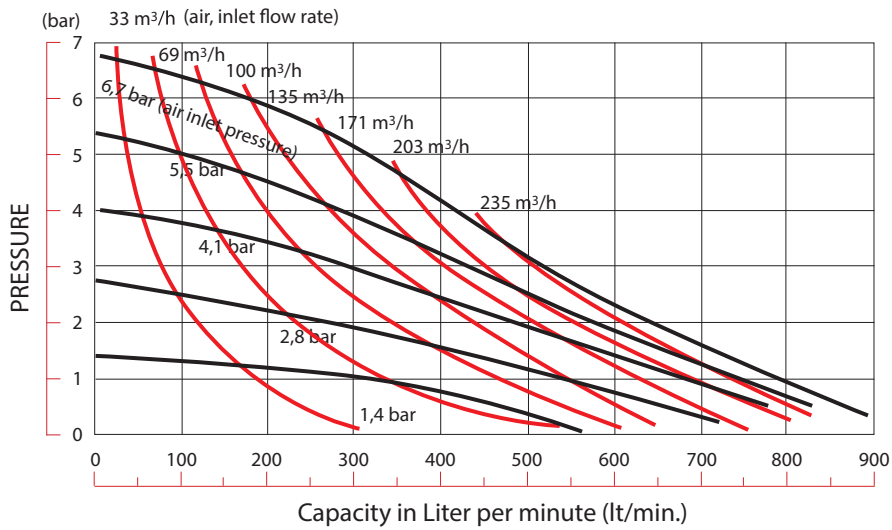

PUMP EXTERNAL DIMENSIONS

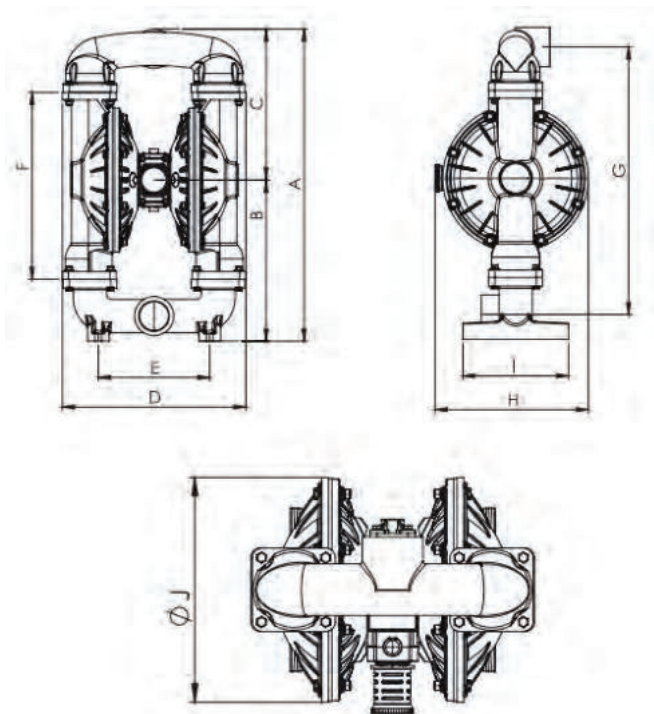

A	B	C	D	E	F	G	H	I	J
858	443	415	504	306	514	735	421	290	400

APPLICATION AREAS

- WASTE WATER TREATMENT
- TEXTILE
- PACKAGING
- AUTOMOTIVE
- FOOD INDUSTRY
- PAINT INDUSTRY
- MINING - ENERGY
- MARINE
- MACHINE-AUTOMATION
- DEFENSE INDUSTRY
- PETROL AND OIL
- CERAMIC INDUSTRY
- MEDICAL INDUSTRY



ADVANTAGES

- 1) Solid particles may pass through the pump.
- 2) Maintenance cost is low.
- 3) Liquid flow rate can also be adjusted when the air inlet pressure of the pump is adjusted.
- 4) The pump's air valve and pilot valve repair kits can be repaired without disassembling the pump.
- 5) It has the feature of working dry.
- 6) The suction depth of this pump is 6 m.
- 7) The liquid connection of the pump can be both flange and threaded.
- 8) It can be preferred where the pump outlet pressure should be higher than 7 bar.

PUMP TECHNICAL SPECIFICATIONS

- Max. Capacity** : 75 l/min
- Fluid Inlet-Outlet** : 1"
- Max. Fluid Discharge** : 14 bar
- Body Material** : Aluminum, Cast Iron, Stainless Steel
- Air Inlet Size** : 1/2"
- Solid Particle Size** : 4 mm
- Dry Suction Depth** : 6 m
- Max Air Pressure** : 7 bar
- Diaphragm Options** : Santoprene, Neoprene, Buna-N, EPDM, Viton
- Ball Options** : Santoprene, Neoprene, Buna-N, EPDM, Viton
- Ball Seat Options** : Santoprene, Neoprene, Buna-N, EPDM, Viton

DIAPHRAGM PUMPS PERFORMANCE CURVES

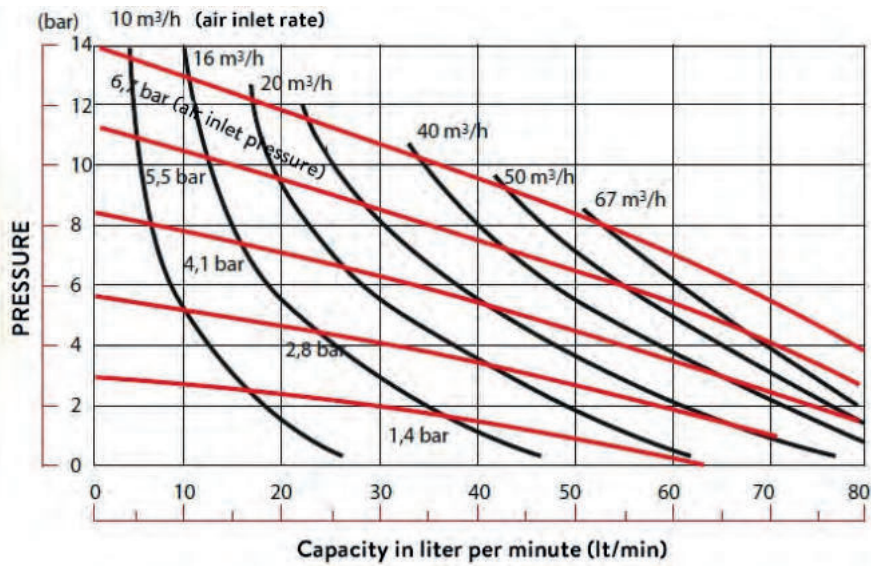

PUMP EXTERNAL DIMENSIONS

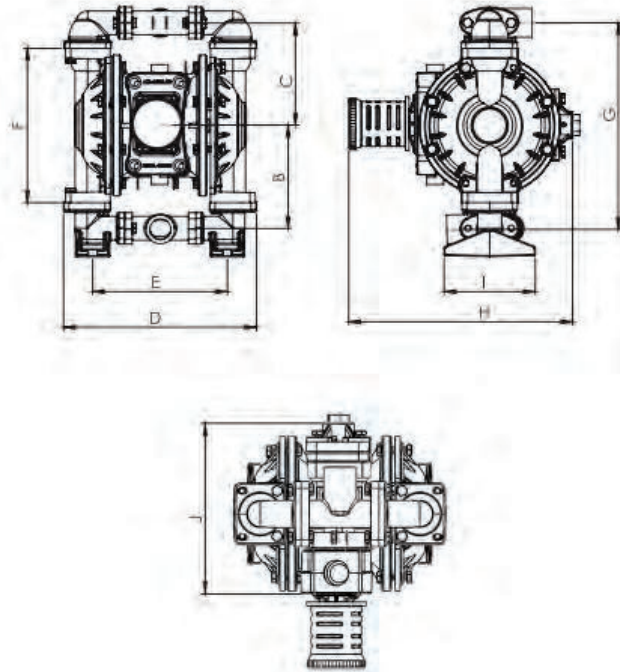

A	B	C	D	E	F	G	H	I	J
356	146	146	274	191	220	293	312	130	220



APPLICATION AREAS:



- | | |
|---|--|
|  WASTE WATER TREATMENT |  MARINE |
|  TEXTILE |  MACHINE-AUTOMATION |
|  PACKAGING |  DEFENSE INDUSTRY |
|  AUTOMOTIVE |  PETROL AND OIL |
|  FOOD INDUSTRY |  CERAMIC INDUSTRY |
|  PAINT INDUSTRY |  MEDICAL INDUSTRY |
|  MINING - ENERGY | |

ADVANTAGES



- 1) Solid particles may pass through the pump.
- 2) Maintenance cost is low.
- 3) Liquid flow rate can also be adjusted when the air inlet pressure of the pump is adjusted.
- 4) The pump's air valve and pilot valve repair kits can be repaired without disassembling the pump.
- 5) It has the feature of working dry.
- 6) The suction depth of this pump is 6 m.
- 7) The liquid connection of the pump can be both flange and threaded.
- 8) It can be preferred where the pump outlet pressure should be higher than 7 bar.

PUMP TECHNICAL SPECIFICATIONS



- | | |
|-----------------------------|---|
| Max. Capacity | : 200 l/min |
| Fluid Inlet-Outlet | : 1½" |
| Max. Fluid Discharge | : 14 bar |
| Body Material | : Aluminum, Cast Iron, Stainless Steel |
| Air Inlet Size | : 3/4" |
| Solid Particle Size | : 6 mm |
| Dry Suction Depth | : 6 m |
| Max Air Pressure | : 7 bar |
| Diaphragm Options | : Santoprene, Neoprene, Buna-N, EPDM, Viton |
| Ball Options | : Santoprene, Neoprene, Buna-N, EPDM, Viton |
| Ball Seat Options | : Santoprene, Neoprene, Buna-N, EPDM, Viton |

DIAPHRAGM PUMPS PERFORMANCE CURVES

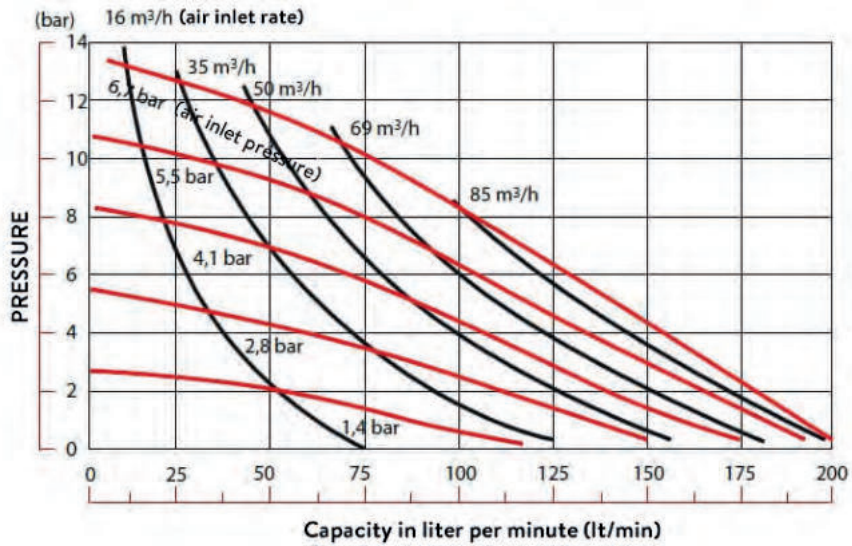

PUMP EXTERNAL DIMENSIONS

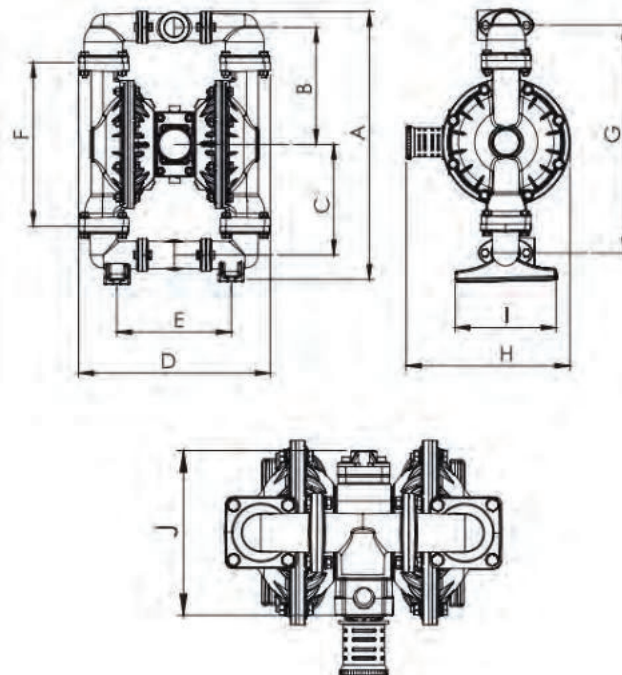

A	B	C	D	E	F	G	H	I	J
605	260	245	425	253	363	505	363	224	253



APPLICATION AREAS:



- | | |
|---|--|
|  WASTE WATER TREATMENT |  MARINE |
|  TEXTILE |  MACHINE-AUTOMATION |
|  PACKAGING |  DEFENSE INDUSTRY |
|  AUTOMOTIVE |  PETROL AND OIL |
|  FOOD INDUSTRY |  CERAMIC INDUSTRY |
|  PAINT INDUSTRY |  MEDICAL INDUSTRY |
|  MINING - ENERGY | |

ADVANTAGES



- 1) Solid particles may pass through the pump.
- 2) Maintenance cost is low.
- 3) Liquid flow rate can also be adjusted when the air inlet pressure of the pump is adjusted.
- 4) The pump's air valve and pilot valve repair kits can be repaired without disassembling the pump.
- 5) It has the feature of working dry.
- 6) The suction depth of this pump is 6 m.
- 7) The liquid connection of the pump can be both flange and threaded.
- 8) It can be preferred where the pump outlet pressure should be higher than 7 bar.

PUMP TECHNICAL SPECIFICATIONS



- | | |
|-----------------------------|---|
| Max. Capacity | : 280 l/min |
| Fluid Inlet-Outlet | : 2" |
| Max. Fluid Discharge | : 14 bar |
| Body Material | : Aluminum, Cast Iron, Stainless Steel |
| Air Inlet Size | : 3/4" |
| Solid Particle Size | : 6 mm |
| Dry Suction Depth | : 6 m |
| Max Air Pressure | : 7 bar |
| Diaphragm Options | : Santoprene, Neoprene, Buna-N, EPDM, Viton |
| Ball Options | : Santoprene, Neoprene, Buna-N, EPDM, Viton |
| Ball Seat Options | : Santoprene, Neoprene, Buna-N, EPDM, Viton |

DIAPHRAGM PUMPS PERFORMANCE CURVES

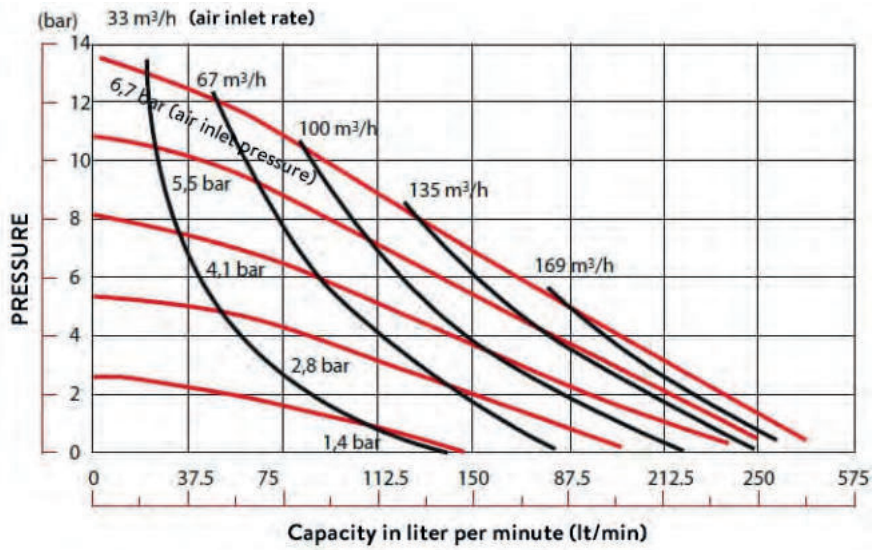

PUMP EXTERNAL DIMENSIONS

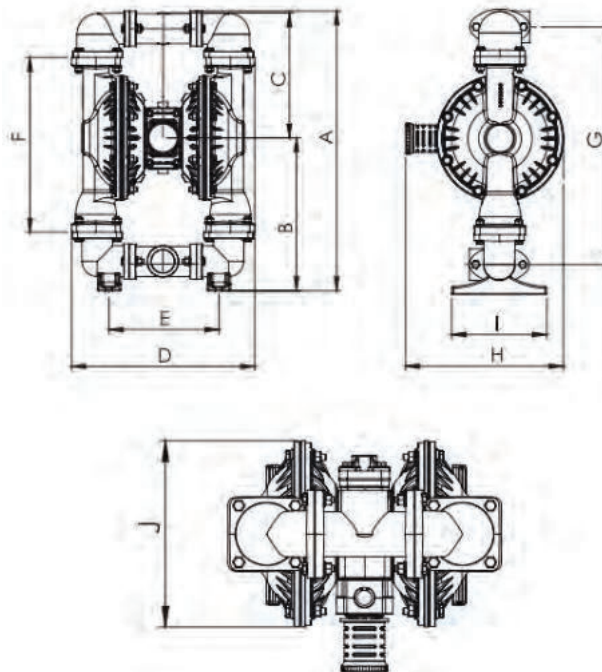

A	B	C	D	E	F	G	H	I	J
669	365	299	438	263	418	556	370	223	298



APPLICATION AREAS:



- | | |
|---|--|
|  WASTE WATER TREATMENT |  MARINE |
|  TEXTILE |  MACHINE-AUTOMATION |
|  PACKAGING |  DEFENSE INDUSTRY |
|  AUTOMOTIVE |  PETROL AND OIL |
|  FOOD INDUSTRY |  CERAMIC INDUSTRY |
|  PAINT INDUSTRY |  MEDICAL INDUSTRY |
|  MINING - ENERGY | |

ADVANTAGES



- 1) Solid particles may pass through the pump.
- 2) Maintenance cost is low.
- 3) Liquid flow rate can also be adjusted when the air inlet pressure of the pump is adjusted.
- 4) The pump's air valve and pilot valve repair kits can be repaired without disassembling the pump.
- 5) It has the feature of working dry.
- 6) The suction depth of this pump is 6 m.
- 7) The liquid connection of the pump can be both flange and threaded.
- 8) It can be preferred where the pump outlet pressure should be higher than 7 bar.

PUMP TECHNICAL SPECIFICATIONS



- | | |
|-----------------------------|---|
| Max. Capacity | : 445 l/min |
| Fluid Inlet-Outlet | : 3" |
| Max. Fluid Discharge | : 14 bar |
| Body Material | : Aluminum, Cast Iron, Stainless Steel |
| Air Inlet Size | : 3/4" |
| Solid Particle Size | : 8 mm |
| Dry Suction Depth | : 6 m |
| Max Air Pressure | : 7 bar |
| Diaphragm Options | : Santoprene, Neoprene, Buna-N, EPDM, Viton |
| Ball Options | : Santoprene, Neoprene, Buna-N, EPDM, Viton |
| Ball Seat Options | : Santoprene, Neoprene, Buna-N, EPDM, Viton |

DIAPHRAGM PUMPS PERFORMANCE CURVES

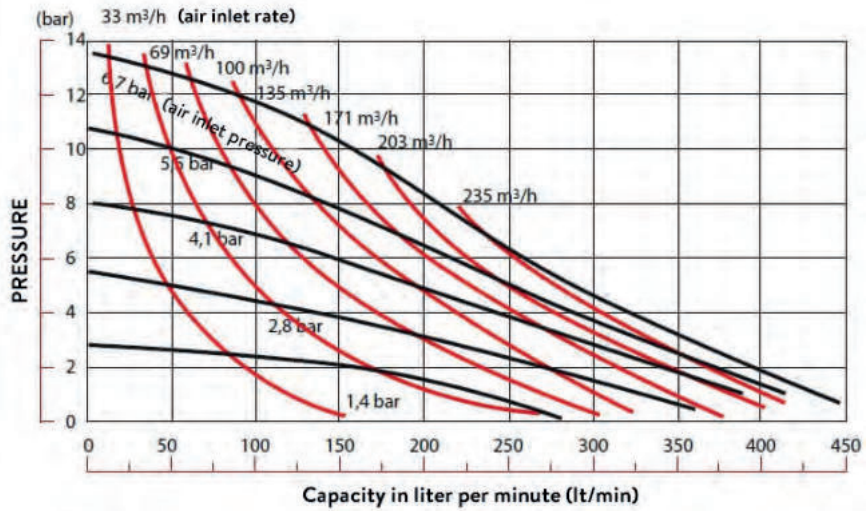

PUMP EXTERNAL DIMENSIONS

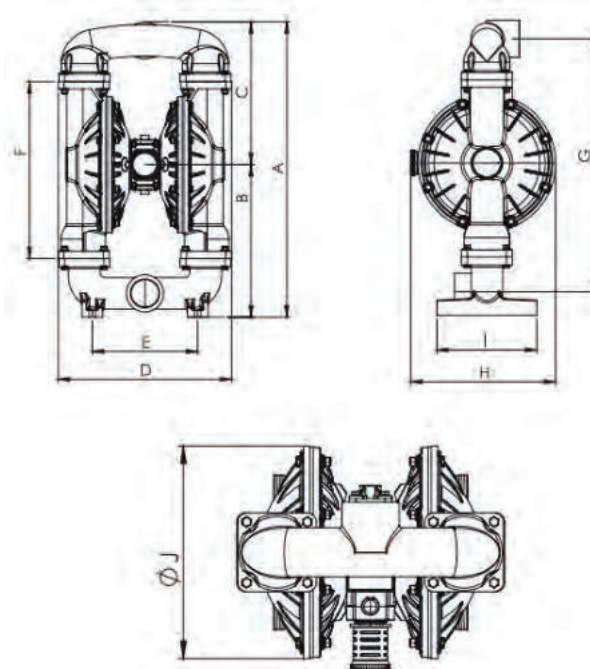

A	B	C	D	E	F	G	H	I	J
858	443	415	504	306	514	735	421	290	400



APPLICATION AREAS

- 

WASTE WATER TREATMENT
- 

MINING - ENERGY
- 

TEXTILE
- 

MARINE
- 

PACKAGING
- 

MACHINE-AUTOMATION
- 

AUTOMOTIVE
- 

FOOD INDUSTRY
- 

PAINT INDUSTRY

ADVANTAGES

- 1) Solid particles may pass through the pump.
- 2) Maintenance cost is low.
- 3) Liquid flow rate can also be adjusted when the air inlet pressure of the pump is adjusted.
- 4) The pump's air valve and pilot valve repair kits can be repaired without disassembling the pump.
- 5) It has the feature of working dry.
- 6) The suction depth of this pump is 6 m.
- 7) It can provide the transfer of two different liquids at the same time without mixing with each other.

PUMP TECHNICAL SPECIFICATIONS

- Max. Capacity** : 55 l/min
- Fluid Inlet-Outlet** : 3/4"
- Max. Fluid Discharge** : 7 bar
- Body Material** : Aluminum, Cast Iron, Stainless Steel
- Air Inlet Size** : 1/4"
- Solid Particle Size** : 3 mm
- Dry Suction Depth** : 6 m
- Max Air Pressure** : 7 bar
- Diaphragm Options** : Santoprene, Neoprene, Buna-N, EPDM, Teflon, Viton
- Ball Options** : Santoprene, Neoprene, Buna-N, EPDM, Teflon, Viton
- Ball Seat Options** : Santoprene, Neoprene, Buna-N, EPDM, Teflon, Viton

DIAPHRAGM PUMPS PERFORMANCE CURVES

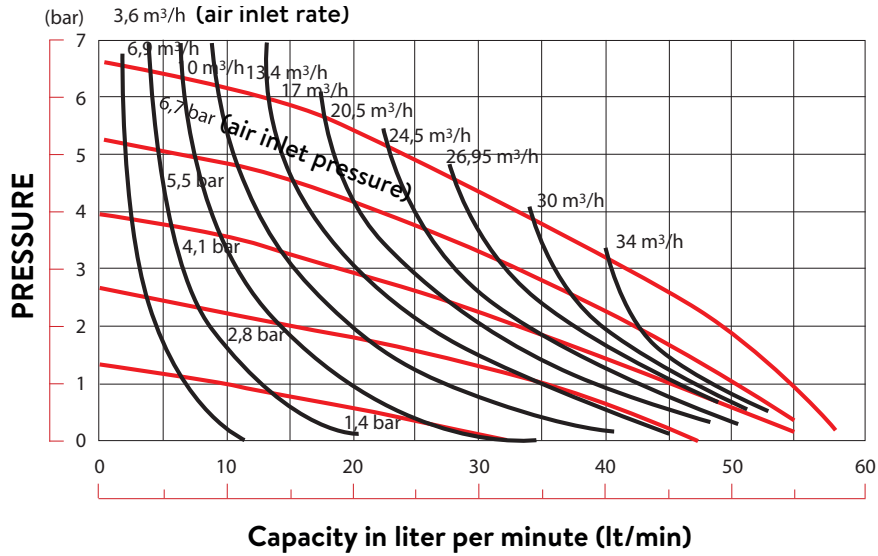

PUMP EXTERNAL DIMENSIONS

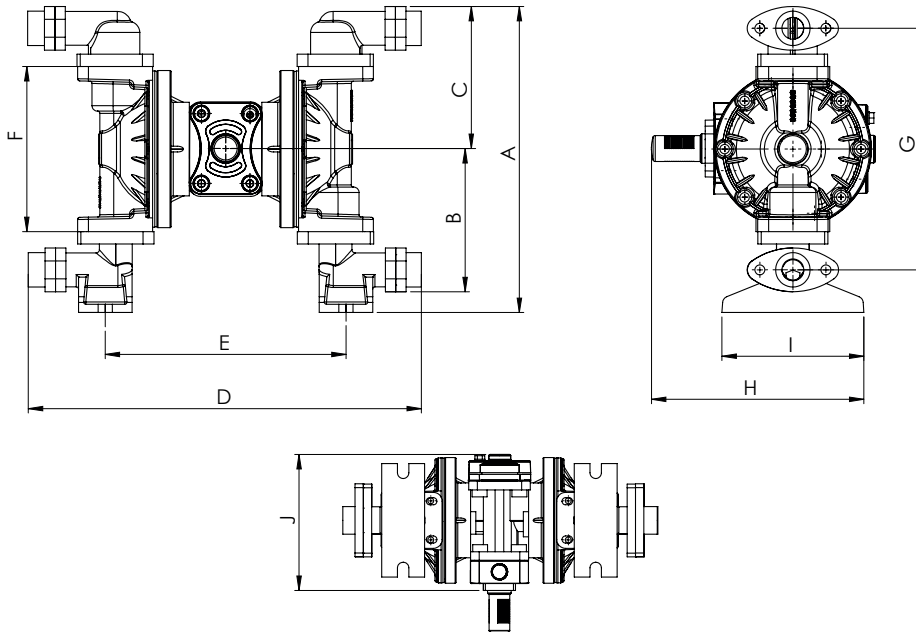

A	B	C	D	E	F	G	H	I	J
280	130	130	360	220	151	221	195	130	163



APPLICATION AREAS

- WASTE WATER TREATMENT
- TEXTILE
- PACKAGING
- AUTOMOTIVE
- FOOD INDUSTRY
- PAINT INDUSTRY
- MINING - ENERGY
- MARINE
- MACHINE-AUTOMATION
- DEFENSE INDUSTRY
- PETROL AND OIL
- CERAMIC INDUSTRY
- MEDICAL INDUSTRY

ADVANTAGES

- 1) Solid particles may pass through the pump.
- 2) Maintenance cost is low.
- 3) Liquid flow rate can also be adjusted when the air inlet pressure of the pump is adjusted.
- 4) The pump's air valve and pilot valve repair kits can be repaired without disassembling the pump.
- 5) It has the feature of working dry.
- 6) The suction depth of this pump is 6 m.
- 7) It can provide the transfer of two different liquids at the same time without mixing with each other.

PUMP TECHNICAL SPECIFICATIONS

- Max. Capacity** : 150 l/min
- Fluid Inlet-Outlet** : 1"
- Max. Fluid Discharge** : 7 bar
- Body Material** : Aluminum, Cast Iron, Stainless Steel
- Air Inlet Size** : 1/2"
- Solid Particle Size** : 4 mm
- Dry Suction Depth** : 6 m
- Max Air Pressure** : 7 bar
- Diaphragm Options** : Santoprene, Neoprene, Buna-N, EPDM, Teflon, Viton
- Ball Options** : Santoprene, Neoprene, Buna-N, EPDM, Teflon, Viton
- Ball Seat Options** : Santoprene, Neoprene, Buna-N, EPDM, Teflon, Viton

DIAPHRAGM PUMPS PERFORMANCE CURVES

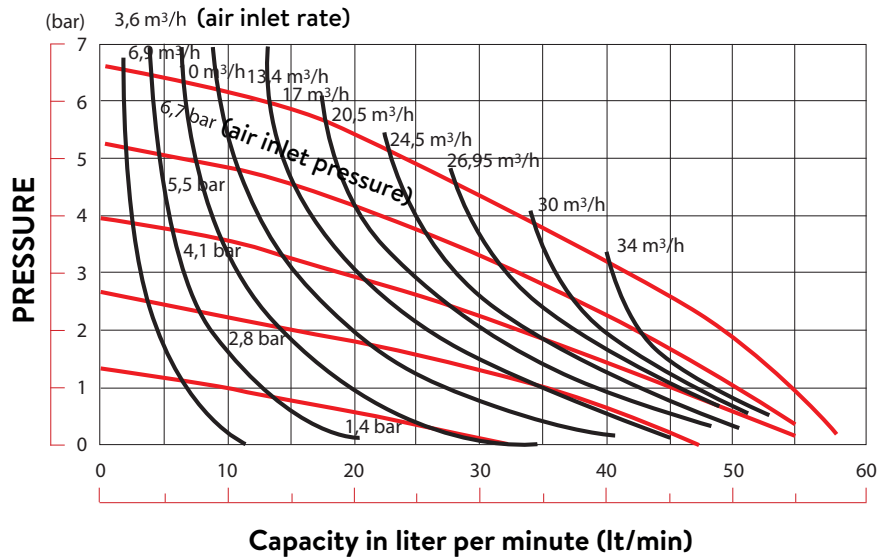

PUMP EXTERNAL DIMENSIONS

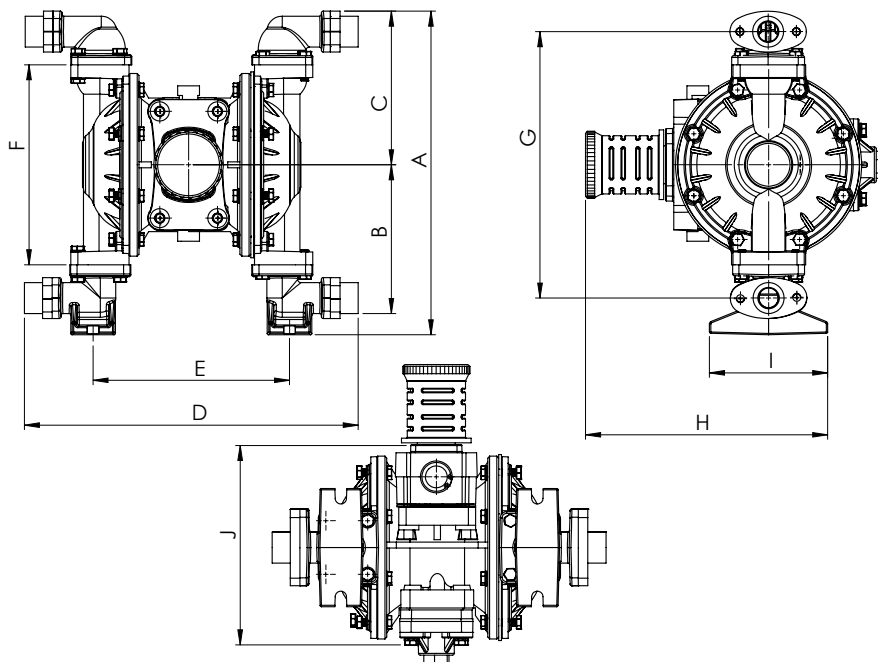

A	B	C	D	E	F	G	H	I	J
356	164	169	367	216	220	293	267	130	220



APPLICATION AREAS



 MACHINE - AUTOMATION

 FOOD INDUSTRY

 COSMETIC INDUSTRY

 MEDICAL INDUSTRY

ADVANTAGES



- 1) Solid particles may pass through the pump.
- 2) Maintenance cost is low.
- 3) Liquid flow rate can also be adjusted when the air inlet pressure of the pump is adjusted.
- 4) The pump's air valve and pilot valve repair kits can be repaired without disassembling the pump.
- 5) It has the feature of working dry.
- 6) The suction depth of this pump is 6 m.

PUMP TECHNICAL SPECIFICATIONS



Max. Capacity	: 55 l/min
Fluid Inlet-Outlet	: 3/4"
Max. Fluid Discharge	: 7 bar
Body Material	: Sheet Stainless
Air Inlet Size	: 1/4"
Solid Particle Size	: 3 mm
Dry Suction Depth	: 6 m
Max Air Pressure	: 7 bar
Diaphragm Options	: Santoprene, Neoprene, Buna-N, EPDM, Teflon, Viton
Ball Options	: Santoprene, Neoprene, Buna-N, EPDM, Teflon, Viton
Ball Seat Options	: Santoprene, Neoprene, Buna-N, EPDM, Teflon, Viton

DIAPHRAGM PUMPS PERFORMANCE CURVES

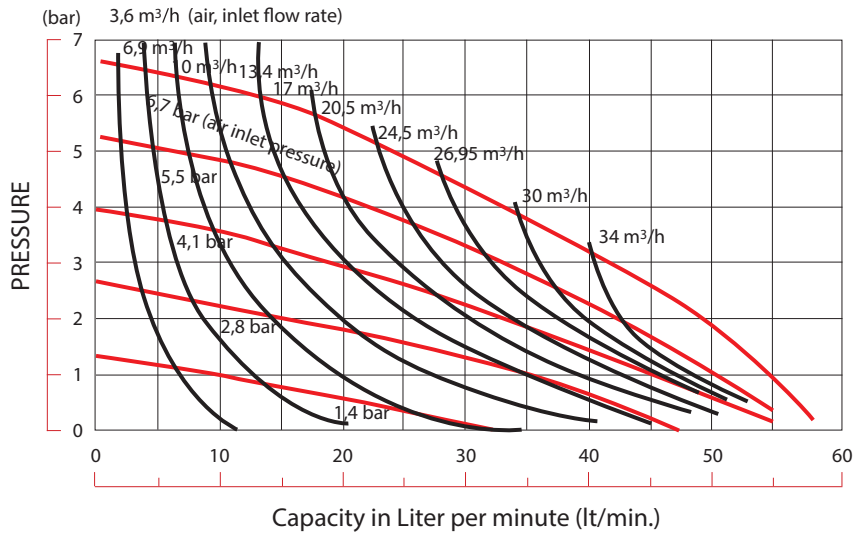

PUMP EXTERNAL DIMENSIONS

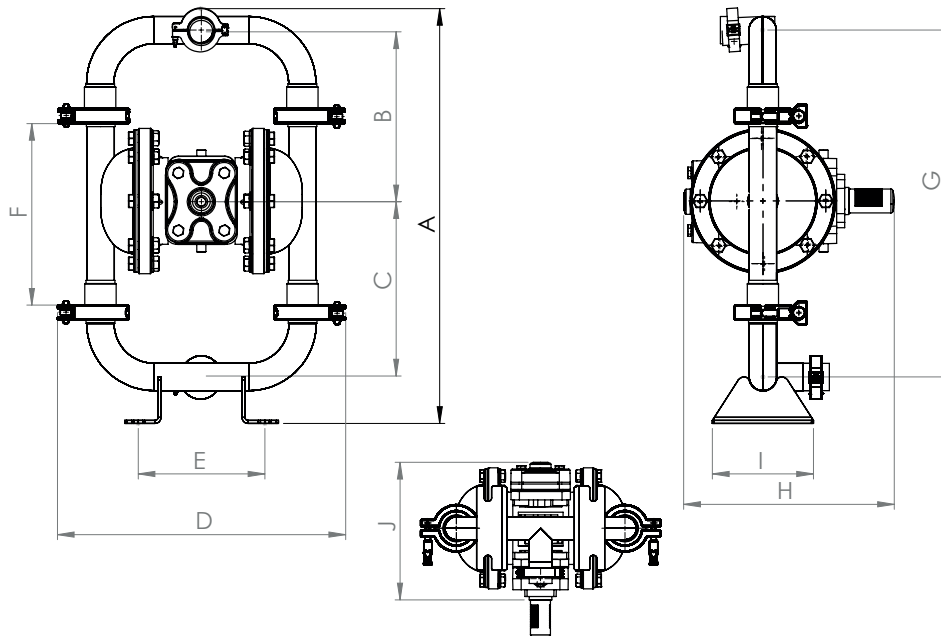

A	B	C	D	E	F	G	H	I	J
410	170	172	285	125	180	343	209	100	165



APPLICATION AREAS



 MACHINE - AUTOMATION

 FOOD INDUSTRY

 COSMETIC INDUSTRY

 MEDICAL INDUSTRY

ADVANTAGES



- 1) Solid particles may pass through the pump.
- 2) Maintenance cost is low.
- 3) Liquid flow rate can also be adjusted when the air inlet pressure of the pump is adjusted.
- 4) The pump's air valve and pilot valve repair kits can be repaired without disassembling the pump.
- 5) It has the feature of working dry.
- 6) The suction depth of this pump is 6 m.

PUMP TECHNICAL SPECIFICATIONS



Max. Capacity	: 150 l/min
Fluid Inlet-Outlet	: 1"
Max. Fluid Discharge	: 7 bar
Body Material	: Sheet Stainless
Air Inlet Size	: ½"
Solid Particle Size	: 4 mm
Dry Suction Depth	: 6 m
Max Air Pressure	: 7 bar
Diaphragm Options	: Santoprene, Neoprene, Buna-N, EPDM, Teflon, Viton
Ball Options	: Santoprene, Neoprene, Buna-N, EPDM, Teflon, Viton
Ball Seat Options	: Santoprene, Neoprene, Buna-N, EPDM, Teflon, Viton

DIAPHRAGM PUMPS PERFORMANCE CURVES

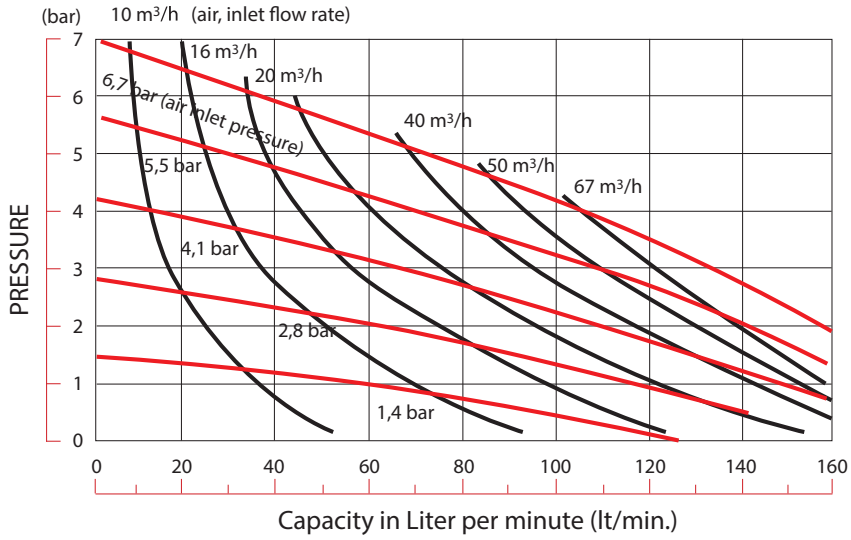

PUMP EXTERNAL DIMENSIONS

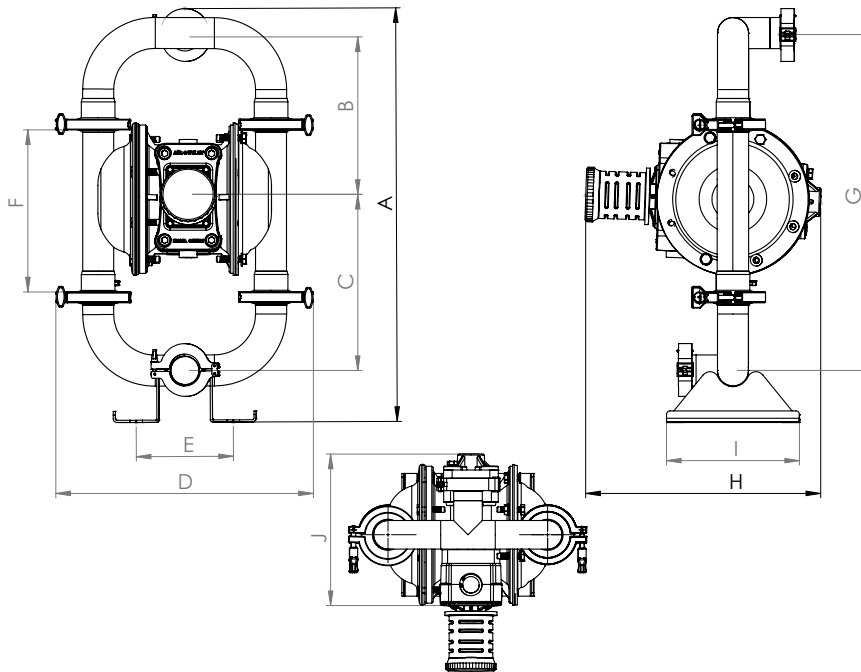

A	B	C	D	E	F	G	H	I	J
560	214	239	350	132	220	455	370	180	222



APPLICATION AREAS



 MACHINE - AUTOMATION

 FOOD INDUSTRY

 COSMETIC INDUSTRY

 MEDICAL INDUSTRY

ADVANTAGES



- 1) Solid particles may pass through the pump.
- 2) Maintenance cost is low.
- 3) Liquid flow rate can also be adjusted when the air inlet pressure of the pump is adjusted.
- 4) The pump's air valve and pilot valve repair kits can be repaired without disassembling the pump.
- 5) It has the feature of working dry.
- 6) The suction depth of this pump is 6 m.

PUMP TECHNICAL SPECIFICATIONS



Max. Capacity	: 400 l/min
Fluid Inlet-Outlet	: 1½"
Max. Fluid Discharge	: 7 bar
Body Material	: Sheet Stainless
Air Inlet Size	: 3/4"
Solid Particle Size	: 6 mm
Dry Suction Depth	: 6 m
Max Air Pressure	: 7 bar
Diaphragm Options	: Santoprene, Neoprene, Buna-N, EPDM, Teflon, Viton
Ball Options	: Santoprene, Neoprene, Buna-N, EPDM, Teflon, Viton
Ball Seat Options	: Santoprene, Neoprene, Buna-N, EPDM, Teflon, Viton

DIAPHRAGM PUMPS PERFORMANCE CURVES

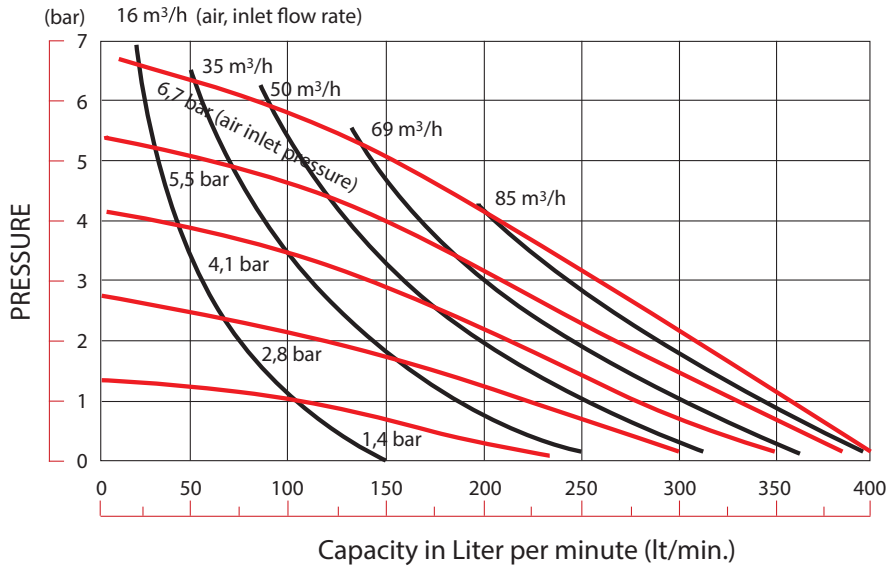

PUMP EXTERNAL DIMENSIONS

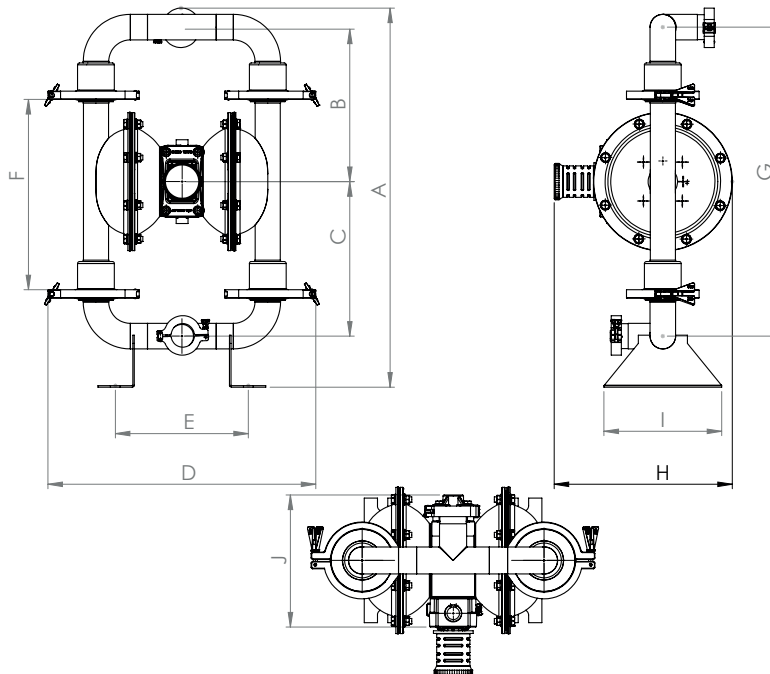

A	B	C	D	E	F	G	H	I	J
773	310	315	546	271	366	630	363	240	255



APPLICATION AREAS

-  MACHINE - AUTOMATION
-  FOOD INDUSTRY
-  COSMETIC INDUSTRY
-  MEDICAL INDUSTRY

ADVANTAGES

- 1) Solid particles may pass through the pump.
- 2) Maintenance cost is low.
- 3) Liquid flow rate can also be adjusted when the air inlet pressure of the pump is adjusted.
- 4) The pump's air valve and pilot valve repair kits can be repaired without disassembling the pump.
- 5) It has the feature of working dry.
- 6) The suction depth of this pump is 6 m.

PUMP TECHNICAL SPECIFICATIONS

Max. Capacity	: 560 l/min
Fluid Inlet-Outlet	: 2"
Max. Fluid Discharge	: 7 bar
Body Material	: Sheet Stainless
Air Inlet Size	: 3/4"
Solid Particle Size	: 6 mm
Dry Suction Depth	: 6 m
Max Air Pressure	: 7 bar
Diaphragm Options	: Santoprene, Neoprene, Buna-N, EPDM, Teflon, Viton
Ball Options	: Santoprene, Neoprene, Buna-N, EPDM, Teflon, Viton
Ball Seat Options	: Santoprene, Neoprene, Buna-N, EPDM, Teflon, Viton

DIAPHRAGM PUMPS PERFORMANCE CURVES

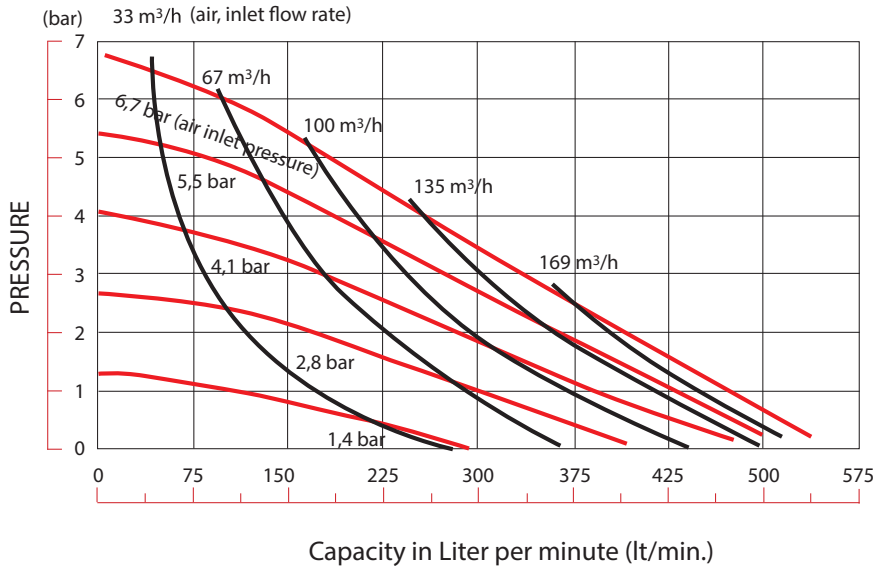

PUMP EXTERNAL DIMENSIONS

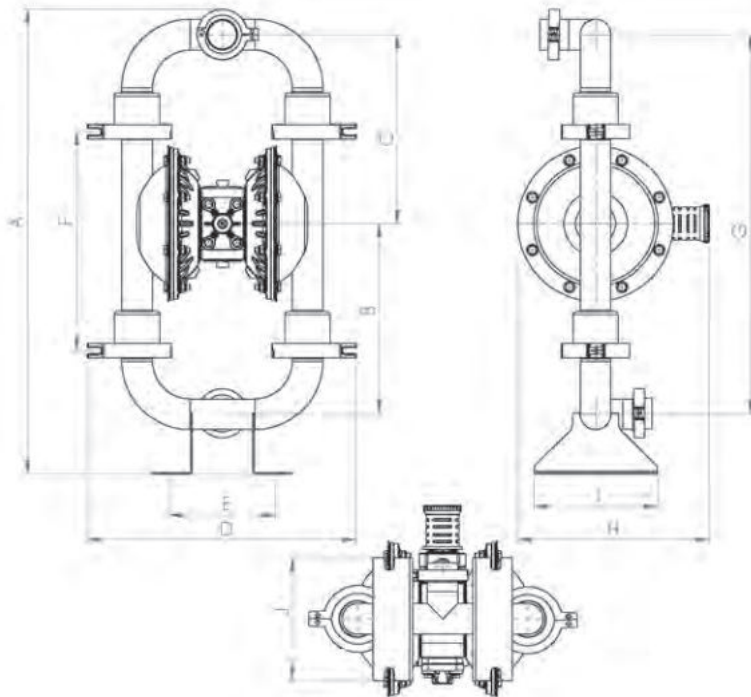

A	B	C	D	E	F	G	H	I	J
905	371	368	524	207	426	740	373	240	240



APPLICATION AREAS



 MACHINE - AUTOMATION

 FOOD INDUSTRY

 COSMETIC INDUSTRY

 MEDICAL INDUSTRY

ADVANTAGES



- 1) Solid particles may pass through the pump.
- 2) Maintenance cost is low.
- 3) Liquid flow rate can also be adjusted when the air inlet pressure of the pump is adjusted.
- 4) The pump's air valve and pilot valve repair kits can be repaired without disassembling the pump.
- 5) It has the feature of working dry.
- 6) The suction depth of this pump is 6 m.

PUMP TECHNICAL SPECIFICATIONS



Max. Capacity	: 890 l/min
Fluid Inlet-Outlet	: 3"
Max. Fluid Discharge	: 7 bar
Body Material	: Sheet Stainless
Air Inlet Size	: 3/4"
Solid Particle Size	: 8 mm
Dry Suction Depth	: 6 m
Max Air Pressure	: 7 bar
Diaphragm Options	: Santoprene, Neoprene, Buna-N, EPDM, Teflon, Viton
Ball Options	: Santoprene, Neoprene, Buna-N, EPDM, Teflon, Viton
Ball Seat Options	: Santoprene, Neoprene, Buna-N, EPDM, Teflon, Viton

DIAPHRAGM PUMPS PERFORMANCE CURVES

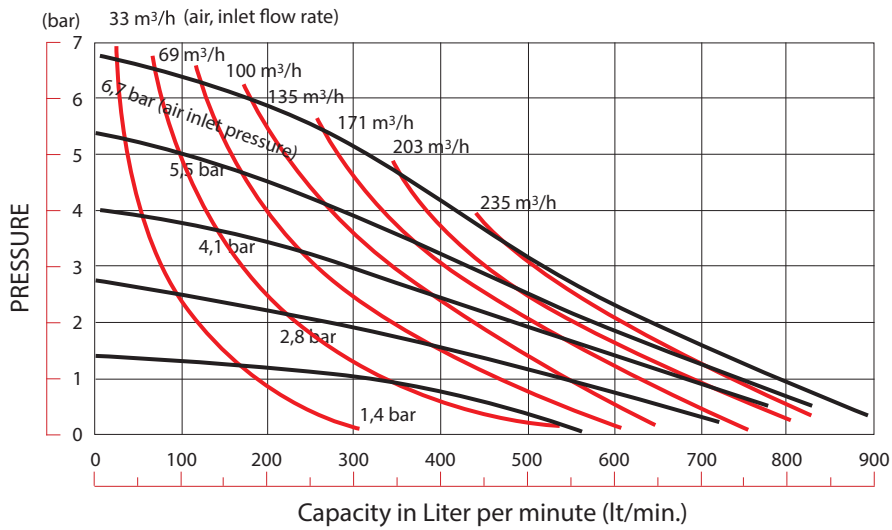

PUMP EXTERNAL DIMENSIONS

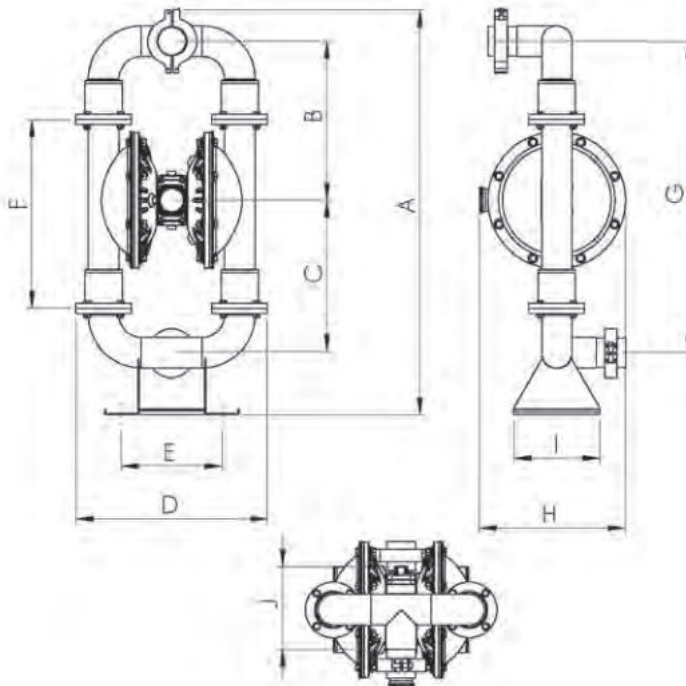

A	B	C	D	E	F	G	H	I	J
1179	463	440	558	294	550	907	425	250	265



APPLICATION AREAS:



-  WASTE WATER TREATMENT
-  TEXTILE
-  PACKAGING
-  CHEMICAL INDUSTRY
-  AUTOMOTIVE
-  FOOD INDUSTRY
-  PAINT INDUSTRY

ADVANTAGES



- 1) Solid particles may pass through the pump.
- 2) The pump is ex-proof. (Suitable for explosive and flammable fluids.)
- 3) Maintenance cost is low.
- 4) Liquid flow rate can also be adjusted when the air inlet pressure of the pump is adjusted.
- 5) The pump's air valve and pilot valve repair kits can be repaired without disassembling the pump.
- 6) It has the feature of working dry.
- 7) The suction depth of this pump is 1 m.

PUMP TECHNICAL SPECIFICATIONS



Max. Capacity	: 16 l/min
Fluid Inlet-Outlet	: 1/4"
Max. Fluid Discharge	: 7 bar
Body Material	: Conductive Polipropilen
Air Inlet Size	: 1/4"
Solid Particle Size	: 1 mm
Dry Suction Depth	: 1m 1,5 m
Max Air Pressure	: 7 bar
Diaphragm Options	: Santoprene, Neoprene, Buna-N, EPDM, Teflon, Viton
Ball Options	: Santoprene, Neoprene, Buna-N, EPDM, Teflon, Viton
Ball Seat Options	: Santoprene, Neoprene, Buna-N, EPDM, Teflon, Viton



Ex h IIB T(80°C) Gb
Ex h IIIB T(80°C) Db
Ex h I M2 T(80°C) Mb

Note: The valve parts of the pumps are made of conductive polypropylene.

DIAPHRAGM PUMPS PERFORMANCE CURVES

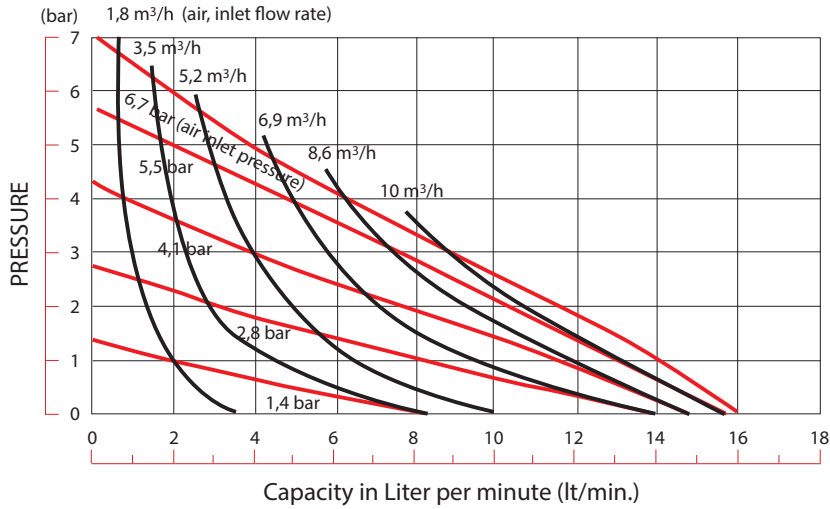

PUMP EXTERNAL DIMENSIONS

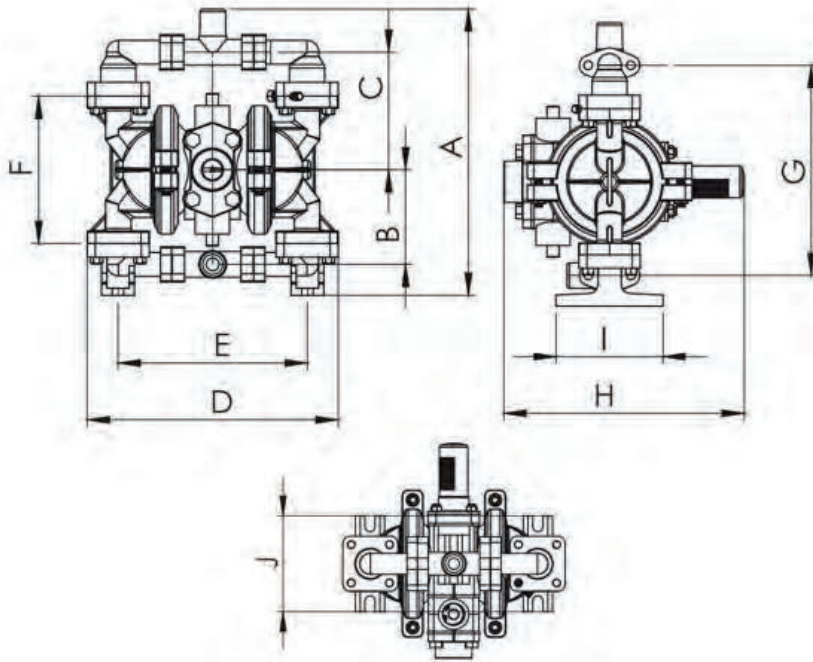

A	B	C	D	E	F	G	H	I	J
212	70	87	186	140	109	157	180	80	80



APPLICATION AREAS

-  WASTE WATER TREATMENT
-  MINING - ENERGY
-  TEXTILE
-  MARINE
-  PACKAGING
-  MACHINE-AUTOMATION
-  CHEMICAL INDUSTRY
-  AUTOMOTIVE
-  FOOD INDUSTRY
-  PAINT INDUSTRY

ADVANTAGES

- 1) Solid particles may pass through the pump.
- 2) The pump is ex-proof. (Suitable for explosive and flammable fluids.)
- 3) Maintenance cost is low.
- 4) Liquid flow rate can also be adjusted when the air inlet pressure of the pump is adjusted.
- 5) The pump's air valve and pilot valve repair kits can be repaired without disassembling the pump.
- 6) It has the feature of working dry.
- 7) The suction depth of this pump is 6 m.
- 8) The liquid connection of the pump can be both flange and threaded.

PUMP TECHNICAL SPECIFICATIONS

Max. Capacity	: 55 l/min
Fluid Inlet-Outlet	: 3/4"
Max. Fluid Discharge	: 7 bar
Body Material	: Conductive Polipropilen
Air Inlet Size	: 1/4"
Solid Particle Size	: 3 mm
Dry Suction Depth	: 6 m
Max Air Pressure	: 7 bar
Diaphragm Options	: Santoprene, Neoprene, Buna-N, EPDM, Teflon, Viton
Ball Options	: Santoprene, Neoprene, Buna-N, EPDM, Teflon, Viton
Ball Seat Options	: Santoprene, Neoprene, Buna-N, EPDM, Teflon, Viton



Ex h IIB T(80°C) Gb
Ex h IIIB T(80°C) Db
Ex h I M2 T(80°C) Mb

Note: The valve parts of the pumps are made of conductive polypropylene.

DIAPHRAGM PUMPS PERFORMANCE CURVES

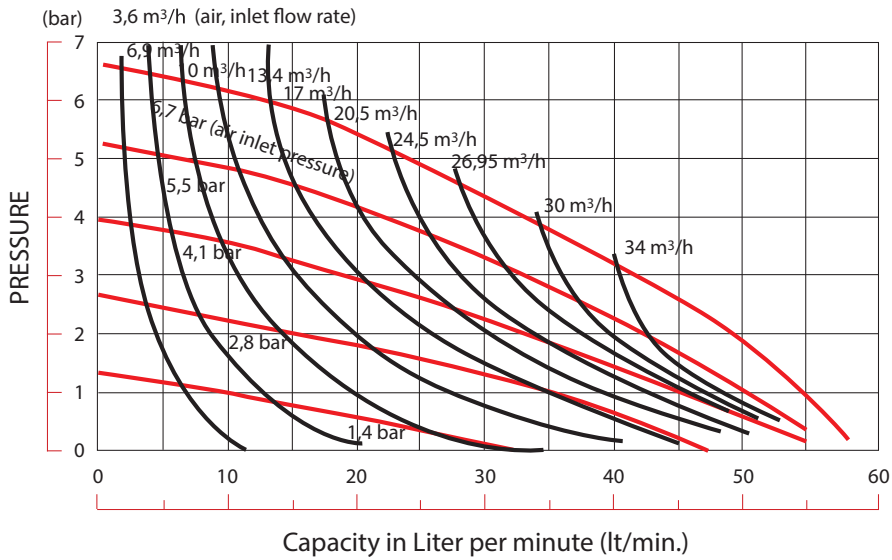

PUMP EXTERNAL DIMENSIONS

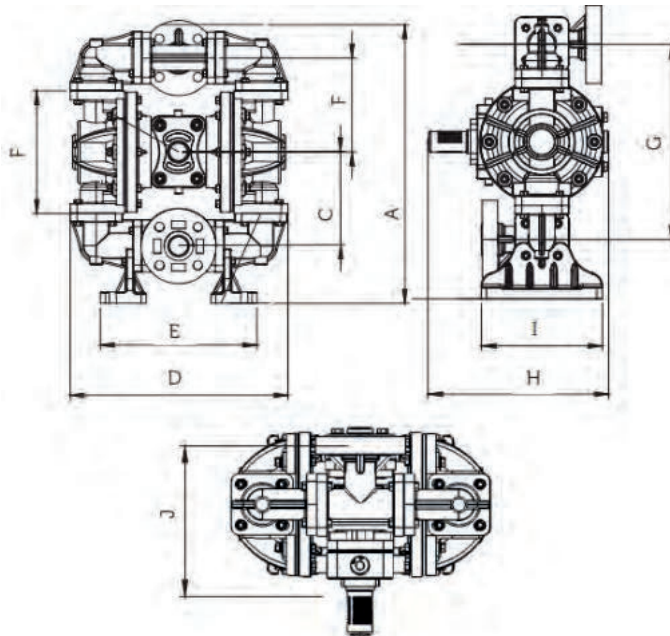

A	B	C	D	E	F	G	H	I	J
340	112	112	262	188	147	225	210	140	152



APPLICATION AREAS:

	WASTE WATER TREATMENT		MINING - ENERGY
	TEXTILE		MARINE
	PACKAGING		MACHINE-AUTOMATION
	CHEMICAL INDUSTRY		BATTERY ACCUMULATOR
	AUTOMOTIVE		COATING INDUSTRY
	FOOD INDUSTRY		DEFENSE INDUSTRY
	PAINT INDUSTRY		

ADVANTAGES

- 1) Solid particles may pass through the pump.
- 2) The pump is ex-proof. (Suitable for explosive and flammable fluids.)
- 3) Maintenance cost is low.
- 4) Liquid flow rate can also be adjusted when the air inlet pressure of the pump is adjusted.
- 5) The pump's air valve and pilot valve repair kits can be repaired without disassembling the pump.
- 6) It has the feature of working dry.
- 7) The suction depth of this pump is 6 m.
- 8) The liquid connection of the pump can be both flange and threaded.

PUMP TECHNICAL SPECIFICATIONS

Max. Capacity	: 150 l/min
Fluid Inlet-Outlet	: 1"
Max. Fluid Discharge	: 7 bar
Body Material	: Conductive Polipropilen
Air Inlet Size	: ½"
Solid Particle Size	: 4 mm
Dry Suction Depth	: 6 m
Max Air Pressure	: 7 bar
Diaphragm Options	: Santoprene, Neoprene, Buna-N, EPDM, Teflon, Viton
Ball Options	: Santoprene, Neoprene, Buna-N, EPDM, Teflon, Viton
Ball Seat Options	: Santoprene, Neoprene, Buna-N, EPDM, Teflon, Viton



Ex h IIB T(80°C) Gb
Ex h IIIB T(80°C) Db
Ex h I M2 T(80°C) Mb

Note: The valve parts of the pumps are made of conductive polypropylene.

DIAPHRAGM PUMPS PERFORMANCE CURVES

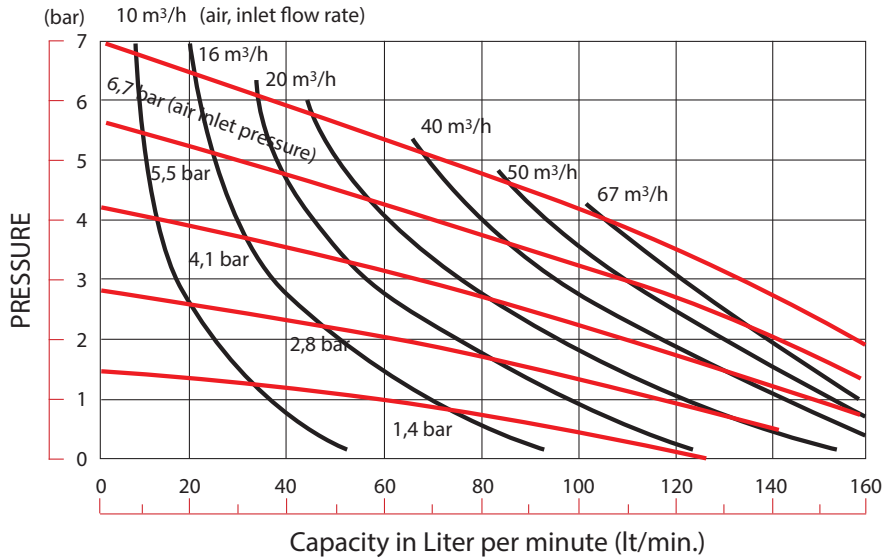

PUMP EXTERNAL DIMENSIONS

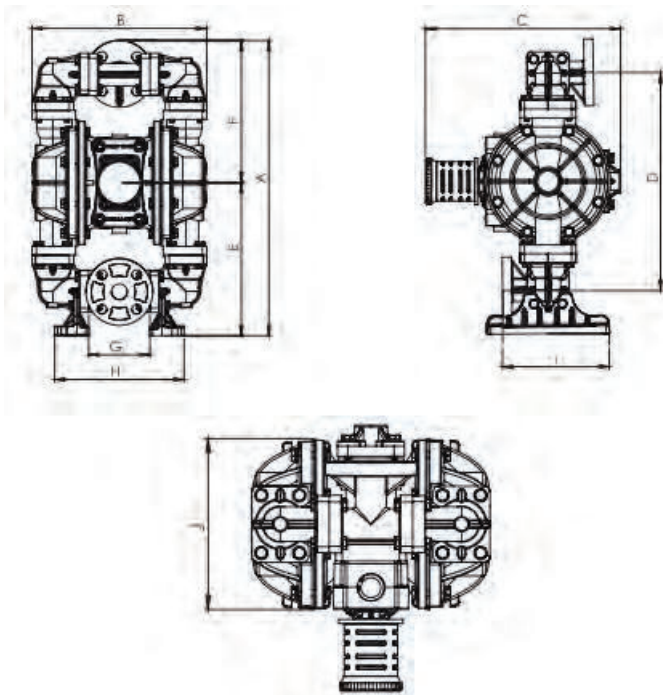

A	B	C	D	E	F	G	H	I	J
482	285	318	356	250	232	100	211	174	205



APPLICATION AREAS

	WASTE WATER TREATMENT		MINING - ENERGY
	TEXTILE		MARINE
	PACKAGING		MACHINE-AUTOMATION
	CHEMICAL INDUSTRY		BATTERY ACCUMULATOR
	AUTOMOTIVE		COATING INDUSTRY
	FOOD INDUSTRY		DEFENSE INDUSTRY
	PAINT INDUSTRY		

ADVANTAGES

- 1) Solid particles may pass through the pump.
- 2) The pump is ex-proof. (Suitable for explosive and flammable fluids.)
- 3) Maintenance cost is low.
- 4) Liquid flow rate can also be adjusted when the air inlet pressure of the pump is adjusted.
- 5) The pump's air valve and pilot valve repair kits can be repaired without disassembling the pump.
- 6) It has the feature of working dry.
- 7) The suction depth of this pump is 6 m.
- 8) The liquid connection of the pump can be both flange and threaded.

PUMP TECHNICAL SPECIFICATIONS

Max. Capacity	: 400 l/min
Fluid Inlet-Outlet	: 1½"
Max. Fluid Discharge	: 7 bar
Body Material	: Conductive Polipropilen
Air Inlet Size	: 3/4"
Solid Particle Size	: 6 mm
Dry Suction Depth	: 6 m
Max Air Pressure	: 7 bar
Diaphragm Options	: Santoprene, Neoprene, Buna-N, EPDM, Teflon, Viton
Ball Options	: Santoprene, Neoprene, Buna-N, EPDM, Teflon, Viton
Ball Seat Options	: Santoprene, Neoprene, Buna-N, EPDM, Teflon, Viton



Ex h IIB T(80°C) Gb
Ex h IIIB T(80°C) Db
Ex h I M2 T(80°C) Mb

Note: The valve parts of the pumps are made of conductive polypropylene.

DIAPHRAGM PUMPS PERFORMANCE CURVES

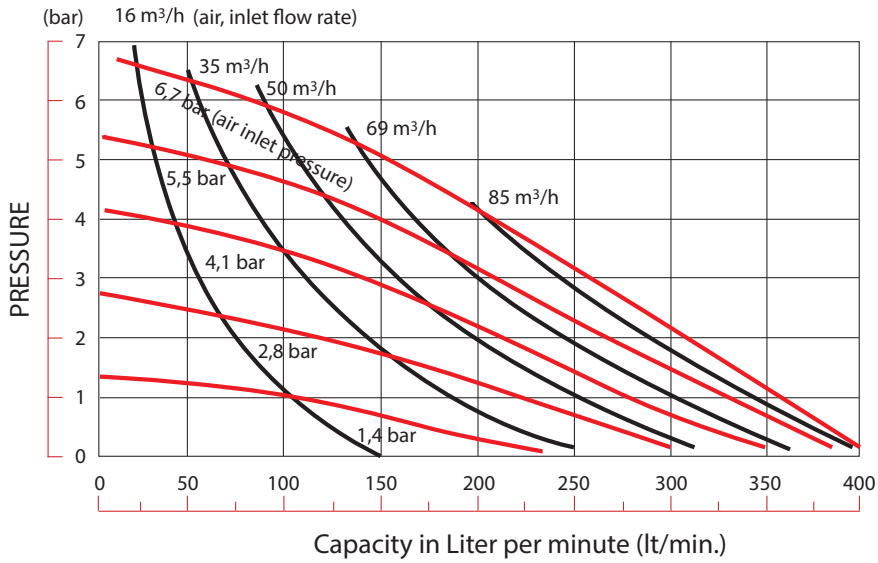

PUMP EXTERNAL DIMENSIONS

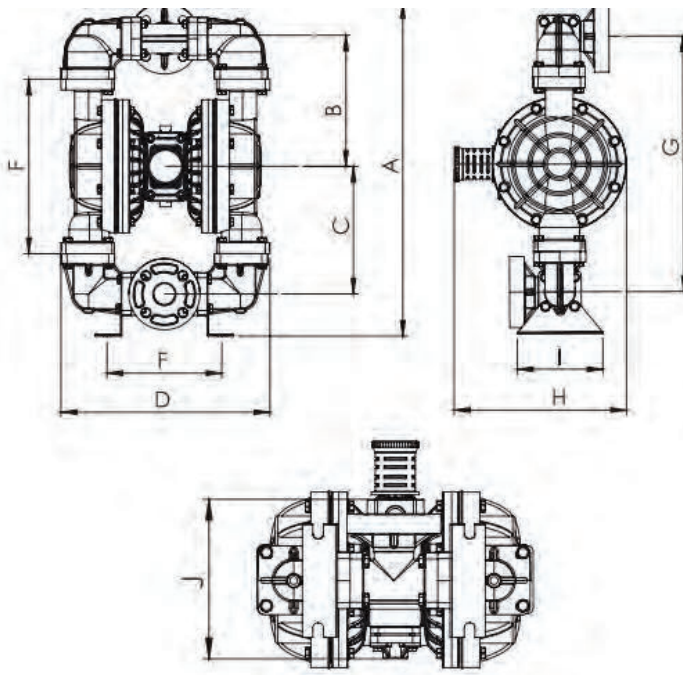

A	B	C	D	E	F	G	H	I	J
703	276	269	440	242	368	538	363	180	254



APPLICATION AREAS

	WASTE WATER TREATMENT		MINING - ENERGY
	TEXTILE		MARINE
	PACKAGING		MACHINE-AUTOMATION
	CHEMICAL INDUSTRY		BATTERY ACCUMULATOR
	AUTOMOTIVE		COATING INDUSTRY
	FOOD INDUSTRY		DEFENSE INDUSTRY
	PAINT INDUSTRY		

ADVANTAGES

- 1) Solid particles may pass through the pump.
- 2) The pump is ex-proof. (Suitable for explosive and flammable fluids.)
- 3) Maintenance cost is low.
- 4) Liquid flow rate can also be adjusted when the air inlet pressure of the pump is adjusted.
- 5) The pump's air valve and pilot valve repair kits can be repaired without disassembling the pump.
- 6) It has the feature of working dry.
- 7) The suction depth of this pump is 6 m.
- 8) The liquid connection of the pump can be both flange and threaded.

PUMP TECHNICAL SPECIFICATIONS

Max. Capacity	: 560 l/min
Fluid Inlet-Outlet	: 2"
Max. Fluid Discharge	: 7 bar
Body Material	: Conductive Polipropilen
Air Inlet Size	: 3/4"
Solid Particle Size	: 6 mm
Dry Suction Depth	: 6 m
Max Air Pressure	: 7 bar
Diaphragm Options	: Santoprene, Neoprene, Buna-N, EPDM, Teflon, Viton
Ball Options	: Santoprene, Neoprene, Buna-N, EPDM, Teflon, Viton
Ball Seat Options	: Santoprene, Neoprene, Buna-N, EPDM, Teflon, Viton



Ex h IIB T(80°C) Gb
Ex h IIIB T(80°C) Db
Ex h I M2 T(80°C) Mb

Note: The valve parts of the pumps are made of conductive polypropylene.

DIAPHRAGM PUMPS PERFORMANCE CURVES

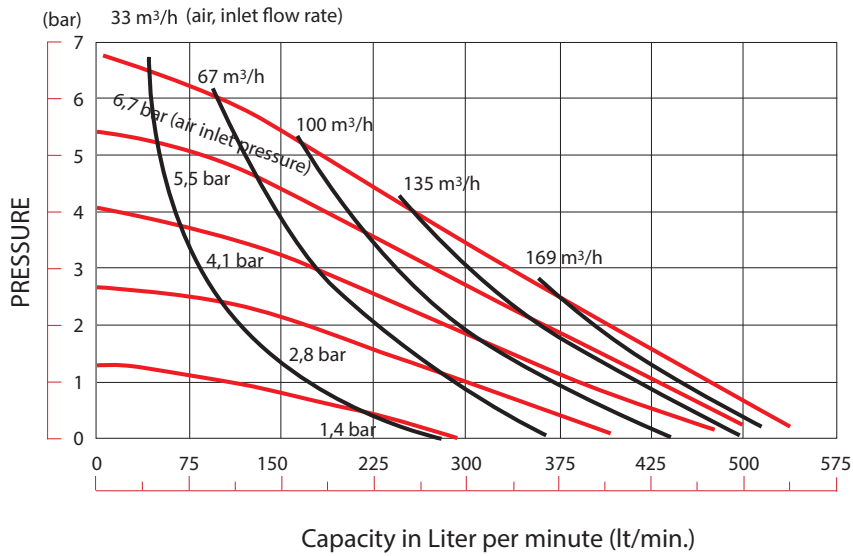

PUMP EXTERNAL DIMENSIONS

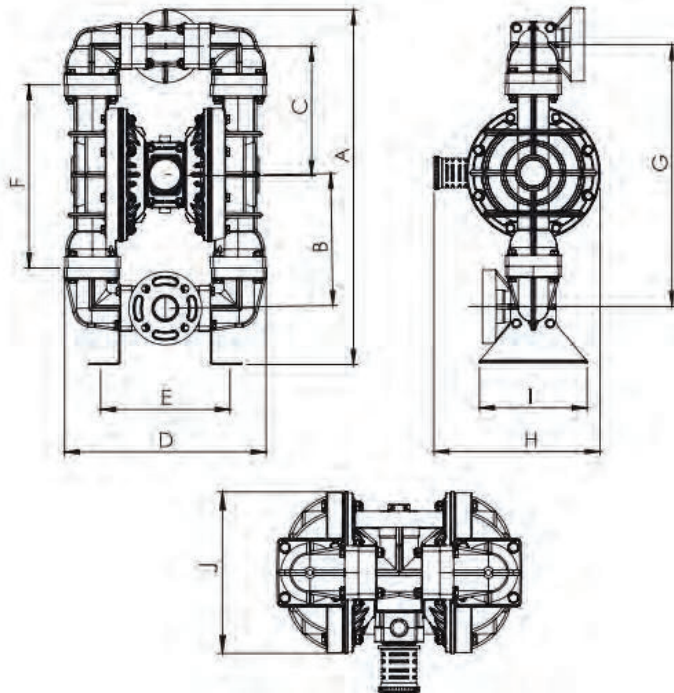



A	B	C	D	E	F	G	H	I	J
790	294	288	450	288	408	584	370	240	298

VP30 PLASTIC BODY ATEX PUMP



APPLICATION AREAS

 WASTE WATER TREATMENT	 MINING - ENERGY
 TEXTILE	 MARINE
 PACKAGING	 MACHINE-AUTOMATION
 CHEMICAL INDUSTRY	 BATTERY ACCUMULATOR
 AUTOMOTIVE	 COATING INDUSTRY
 FOOD INDUSTRY	 DEFENSE INDUSTRY
 PAINT INDUSTRY	

ADVANTAGES

- 1) Solid particles may pass through the pump.
- 2) The pump is ex-proof. (Suitable for explosive and flammable fluids.)
- 3) Maintenance cost is low.
- 4) Liquid flow rate can also be adjusted when the air inlet pressure of the pump is adjusted.
- 5) The pump's air valve and pilot valve repair kits can be repaired without disassembling the pump.
- 6) It has the feature of working dry.
- 7) The suction depth of this pump is 6 m.
- 8) The liquid connection of the pump can be both flange and threaded.

PUMP TECHNICAL SPECIFICATIONS

Max. Capacity	: 890 l/min
Fluid Inlet-Outlet	: 3"
Max. Fluid Discharge	: 7 bar
Body Material	: Conductive Polipropilen
Air Inlet Size	: 3/4"
Solid Particle Size	: 8 mm
Dry Suction Depth	: 6 m
Max Air Pressure	: 7 bar
Diaphragm Options	: Santoprene, Neoprene, Buna-N, EPDM, Teflon, Viton
Ball Options	: Santoprene, Neoprene, Buna-N, EPDM, Teflon, Viton
Ball Seat Options	: Santoprene, Neoprene, Buna-N, EPDM, Teflon, Viton



Ex h IIB T(80°C) Gb
Ex h IIIB T(80°C) Db
Ex h I M2 T(80°C) Mb

Note: The valve parts of the pumps are made of conductive polypropylene.

DIAPHRAGM PUMPS PERFORMANCE CURVES

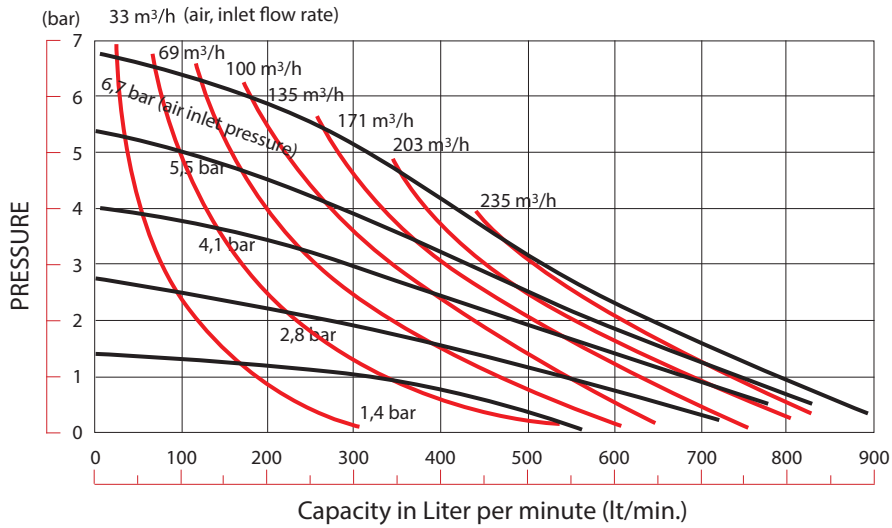

PUMP EXTERNAL DIMENSIONS

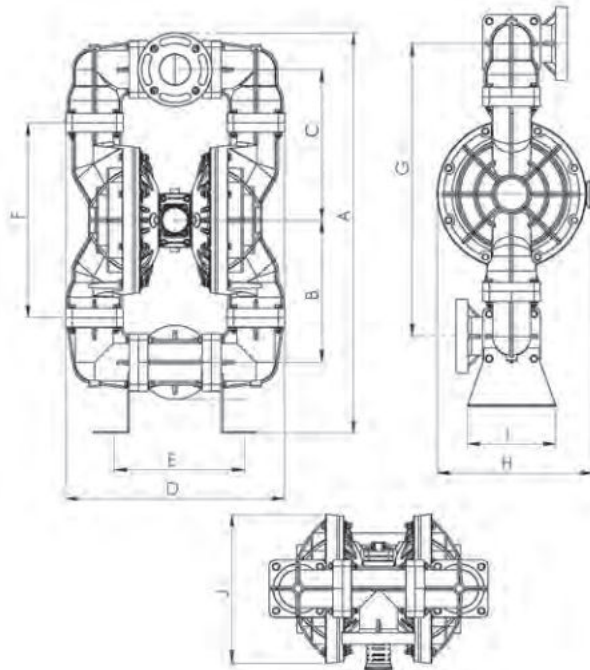

A	B	C	D	E	F	G	H	I	J
1085	385	408	594	353	528	794	424	240	404



APPLICATION AREAS

-  MEDICAL INDUSTRY
-  FOOD INDUSTRY
-  PAINT AND COATING INDUSTRY
-  WASTE WATER TREATMENT
-  CHEMICAL INDUSTRY
-  MINING INDUSTRY
-  CERAMIC INDUSTRY
-  RAFINERY

ADVANTAGES

- 1) Solid particles may pass through the pump.
- 2) It can work with an electric motor in environments where there is no or insufficient air.
- 3) Maintenance cost is low .
- 4) The flow rate can be controlled by connecting the driver to the electric motor of the pump.
- 5) The suction depth of this pump is 2 m.
- 6) It has the feature of working dry. It can absorb up to 2 meters.

PUMP TECHNICAL SPECIFICATIONS

Max. Operating Pressure	: 2 bar
Voltage	: 380/220 volt 50 hz
Energy Consumption	: 0,25 kw
Displacement/Stroke	: 0,25 lt/strok
Max. Discharge Head	: 20 mss
Suction Head	: 2 m
Solid Particle Permeability	: 3 mm
Max. Capacity	: 1,48 m3/h 24.6 l/min
Reducer Speed	: 60 D/d
Max. Çalışma sıcaklığı	: 100 °C
Inlet	: 3/4 inch
Outlet	: 3/4 inch
Body Material	: Aluminum
Diaphragm Options	: Santoprene, Neoprene, Buna-N, EPDM, Teflon, Viton
Ball Options	: Santoprene, Neoprene, Buna-N, EPDM, Teflon, Viton
Ball Seat Options	: Santoprene, Neoprene, Buna-N, EPDM, Teflon, Viton

DIAPHRAGM PUMPS PERFORMANCE CURVES

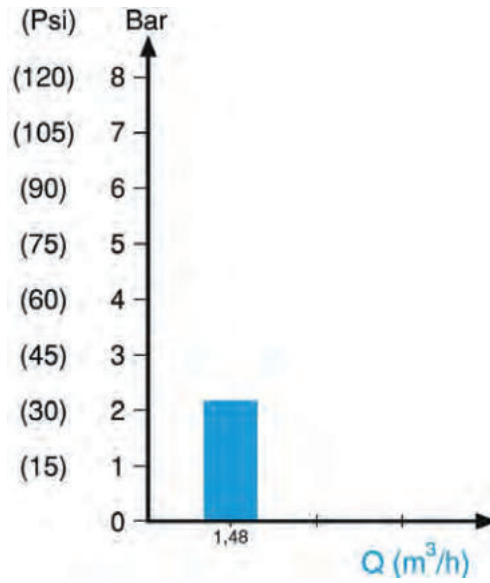

PUMP EXTERNAL DIMENSIONS

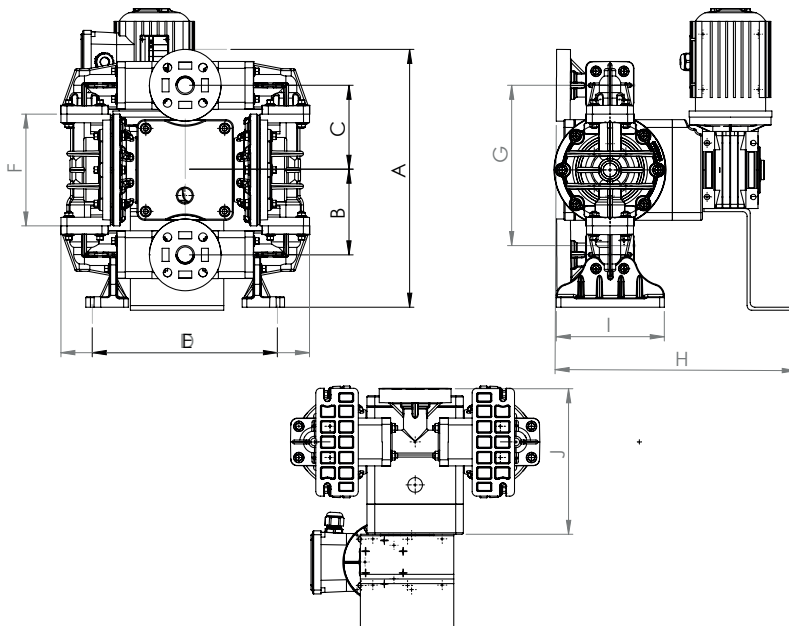

A	B	C	D	E	F	G	H	I	J
335	110	110	323	240	145	208	313	140	190



APPLICATION AREAS

-  MEDICAL INDUSTRY
-  FOOD INDUSTRY
-  PAINT AND COATING INDUSTRY
-  WASTE WATER TREATMENT
-  CHEMICAL INDUSTRY
-  MINING INDUSTRY
-  CERAMIC INDUSTRY
-  RAFINERY

ADVANTAGES

- 1) Solid particles may pass through the pump.
- 2) It can work with an electric motor in environments where there is no or insufficient air.
- 3) Maintenance cost is low .
- 4) The flow rate can be controlled by connecting the driver to the electric motor of the pump.
- 5) The suction depth of this pump is 2 m.
- 6) It has the feature of working dry. It can absorb up to 2 meters.

PUMP TECHNICAL SPECIFICATIONS

Max. Operating Pressure	: 2 bar
Voltage	: 380/220 volt 50 hz
Energy Consumption	: 0,55 kw
Displacement/Stroke	: 0,55 lt/strok
Max. Discharge Head	: 20 mss
Suction Head	: 2 m
Solid Particle Permeability	: 4 mm
Max. Capacity	: 4 m3/h 66.66 l/min
Reducer Speed	: 60 D/d
Max. Çalışma sıcaklığı	: 100 °C
Inlet	: 1 inch
Outlet	: 1 inch
Body Material	: Aluminum
Diaphragm Options	: Santoprene, Neoprene, Buna-N, EPDM, Teflon, Viton
Ball Options	: Santoprene, Neoprene, Buna-N, EPDM, Teflon, Viton
Ball Seat Options	: Santoprene, Neoprene, Buna-N, EPDM, Teflon, Viton

VP10 AL BODY ELECTRIC DIAPHRAGM PUMP

DIAPHRAGM PUMPS PERFORMANCE CURVES

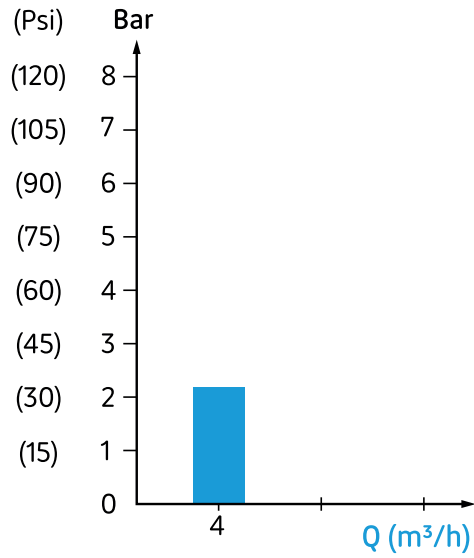

PUMP EXTERNAL DIMENSIONS

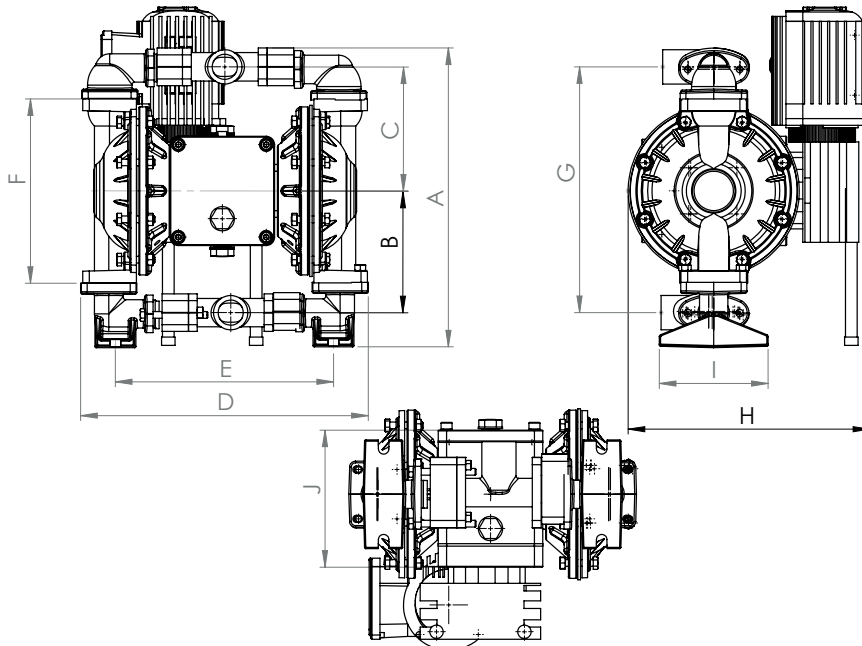

A	B	C	D	E	F	G	H	I	J
358	145	145	345	260	220	295	290	1301	163



APPLICATION AREAS

-  MEDICAL INDUSTRY
-  FOOD INDUSTRY
-  PAINT AND COATING INDUSTRY
-  WASTE WATER TREATMENT
-  CHEMICAL INDUSTRY
-  MINING INDUSTRY
-  CERAMIC INDUSTRY
-  RAFINERY

ADVANTAGES

- 1) Solid particles may pass through the pump.
- 2) It can work with an electric motor in environments where there is no or insufficient air.
- 3) Maintenance cost is low .
- 4) The flow rate can be controlled by connecting the driver to the electric motor of the pump.
- 5) The suction depth of this pump is 4 m.
- 6) It has the feature of working dry. It can absorb up to 4 meters.

PUMP TECHNICAL SPECIFICATIONS

Max. Operating Pressure	: 4 bar
Voltage	: 380 volt 50 hz
Energy Consumption	: 2,2 kw / 3 kw / 4 kw
Displacement/Stroke	: 1,47 lt/strok
Max. Discharge Head	: 40 mss
Suction Head	: 4 m
Solid Particle Permeability	: 6 mm
Max. Capacity	: 13,8 m3/h 230 l/min
Reducer Speed	: 78 D/d
Max. Çalışma sıcaklığı	: 100 °C
Inlet	: 1½ inch
Outlet	: 1½ inch
Body Material	: Aluminum
Diaphragm Options	: Santoprene, Neoprene, Buna-N, EPDM, Teflon, Viton
Ball Options	: Santoprene, Neoprene, Buna-N, EPDM, Teflon, Viton
Ball Seat Options	: Santoprene, Neoprene, Buna-N, EPDM, Teflon, Viton

DIAPHRAGM PUMPS PERFORMANCE CURVES

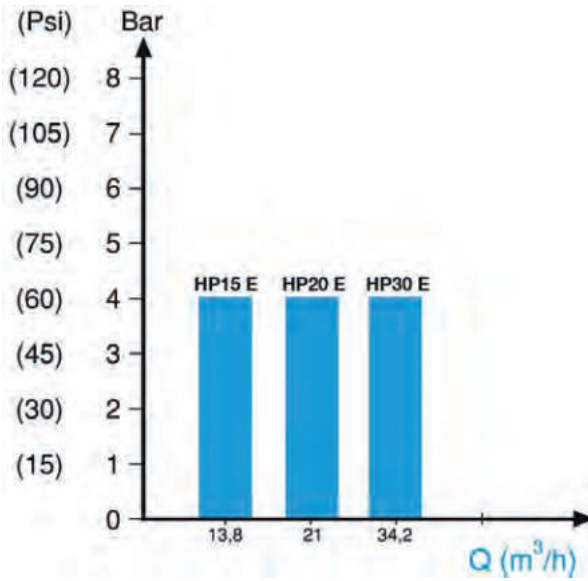

PUMP EXTERNAL DIMENSIONS

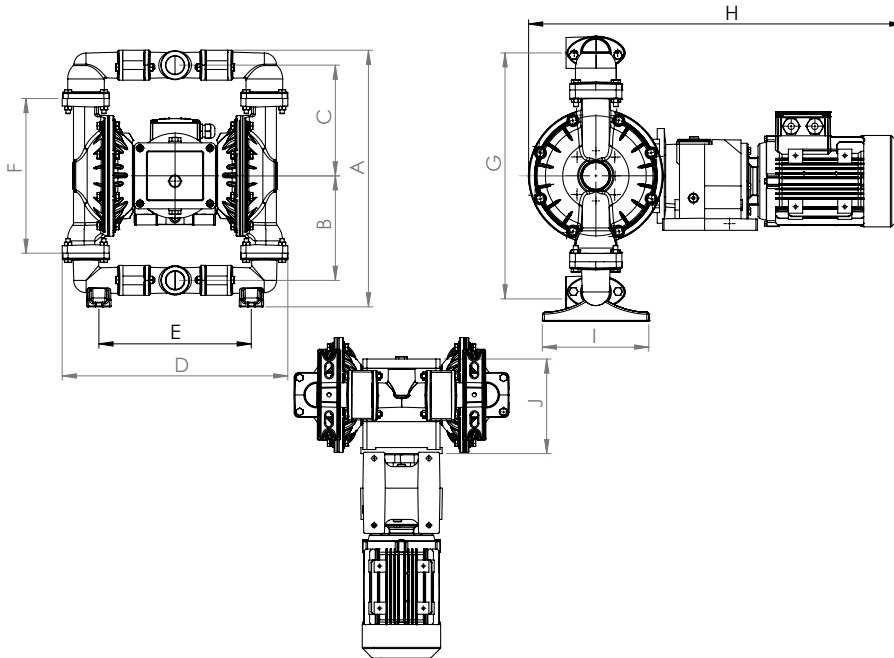

A	B	C	D	E	F	G	H	I	J
603	250	260	530	360	363	520	762	225	233



APPLICATION AREAS

-  MEDICAL INDUSTRY
-  FOOD INDUSTRY
-  PAINT AND COATING INDUSTRY
-  WASTE WATER TREATMENT
-  CHEMICAL INDUSTRY
-  MINING INDUSTRY
-  CERAMIC INDUSTRY
-  RAFINERY

ADVANTAGES

- 1) Solid particles may pass through the pump.
- 2) It can work with an electric motor in environments where there is no or insufficient air.
- 3) Maintenance cost is low .
- 4) The flow rate can be controlled by connecting the driver to the electric motor of the pump.
- 5) The suction depth of this pump is 4 m.
- 6) It has the feature of working dry.

PUMP TECHNICAL SPECIFICATIONS

Max. Operating Pressure	: 4 bar
Voltage	: 380 volt 50 hz
Energy Consumption	: 3kw / 4kw / 5,5 kw
Displacement/Stroke	: 2,24 lt/strok
Max. Discharge Head	: 40 mss
Suction Head	: 4 m
Solid Particle Permeability	: 6 mm
Max. Capacity	: 21 m3/h 350 l/min
Reducer Speed	: 78 D/d
Max. Çalışma sıcaklığı	: 100 °C
Inlet	: 2 inch
Outlet	: 2 inch
Body Material	: Aluminum
Diaphragm Options	: Santoprene, Neoprene, Buna-N, EPDM, Teflon, Viton
Ball Options	: Santoprene, Neoprene, Buna-N, EPDM, Teflon, Viton
Ball Seat Options	: Santoprene, Neoprene, Buna-N, EPDM, Teflon, Viton

DIAPHRAGM PUMPS PERFORMANCE CURVES

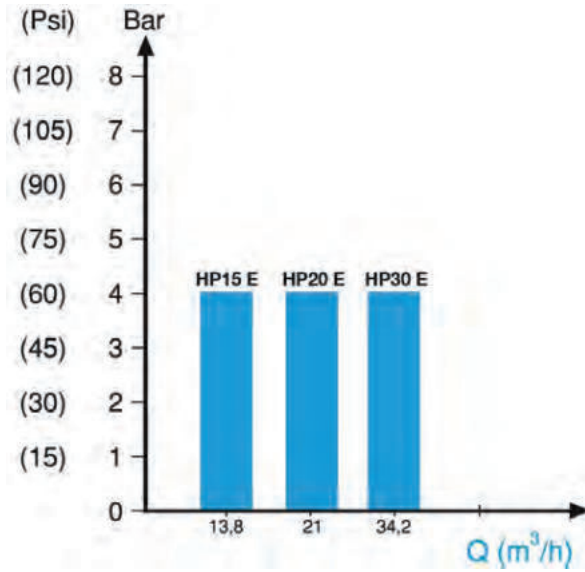

PUMP EXTERNAL DIMENSIONS

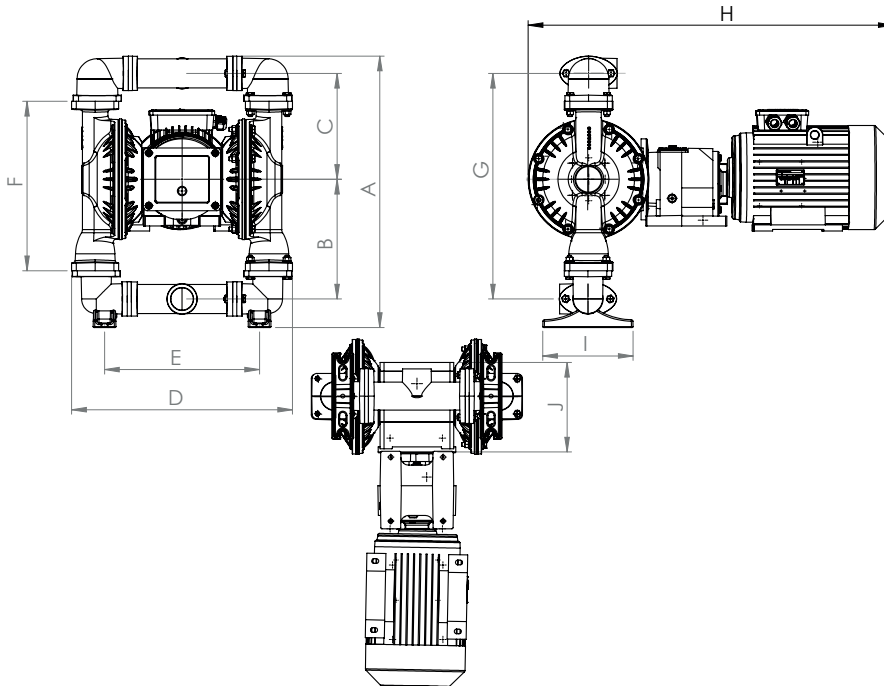

A	B	C	D	E	F	G	H	I	J
670	295	260	545	390	418	567	900	223	231



APPLICATION AREAS

-  MEDICAL INDUSTRY
-  FOOD INDUSTRY
-  PAINT AND COATING INDUSTRY
-  WASTE WATER TREATMENT
-  CHEMICAL INDUSTRY
-  MINING INDUSTRY
-  CERAMIC INDUSTRY
-  RAFINERY

ADVANTAGES

- 1) Solid particles may pass through the pump.
- 2) It can work with an electric motor in environments where there is no or insufficient air.
- 3) Maintenance cost is low .
- 4) The flow rate can be controlled by connecting the driver to the electric motor of the pump.
- 5) The suction depth of this pump is 4 m.
- 6) It has the feature of working dry.

PUMP TECHNICAL SPECIFICATIONS

Max. Operating Pressure	: 4 bar
Voltage	: 380 volt 50 hz
Energy Consumption	: 5,5kw / 7,5 kw
Displacement/Stroke	: 3,65 lt/strok
Max. Discharge Head	: 40 mss
Suction Head	: 4 m
Solid Particle Permeability	: 8 mm
Max. Capacity	: 34,2 m3/h 570 l/min
Reducer Speed	: 78 D/d
Max. Çalışma sıcaklığı	: 100 °C
Inlet	: 3 inch
Outlet	: 3 inch
Body Material	: Aluminum
Diaphragm Options	: Santoprene, Neoprene, Buna-N, EPDM, Teflon, Viton
Ball Options	: Santoprene, Neoprene, Buna-N, EPDM, Teflon, Viton
Ball Seat Options	: Santoprene, Neoprene, Buna-N, EPDM, Teflon, Viton

DIAPHRAGM PUMPS PERFORMANCE CURVES

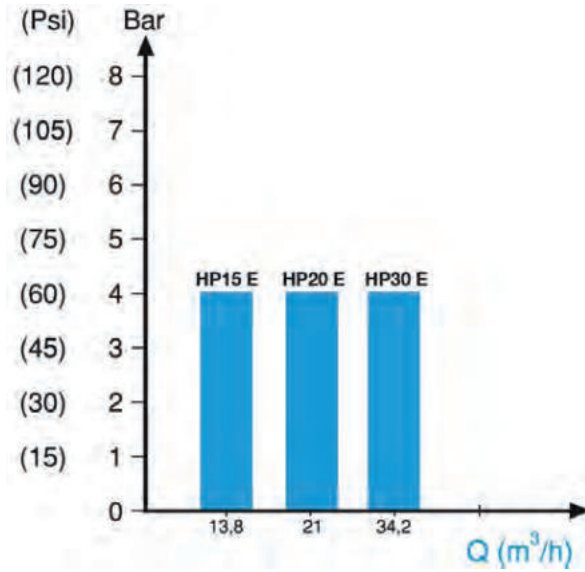

PUMP EXTERNAL DIMENSIONS

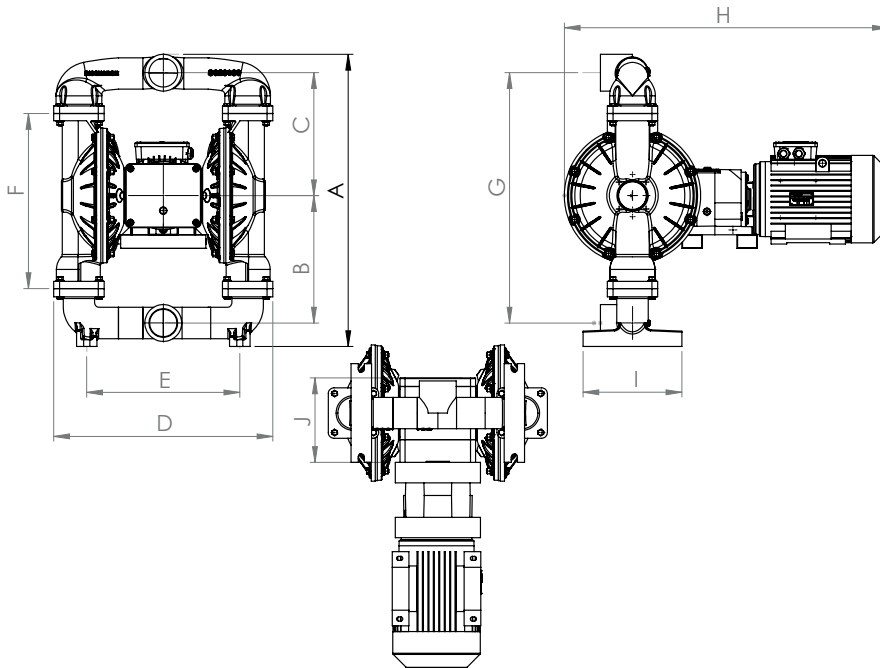

A	B	C	D	E	F	G	H	I	J
858	374	361	645	450	514	735	950	290	248

APPLICATION AREAS



MEDICAL INDUSTRY



FOOD INDUSTRY



PAINT AND COATING INDUSTRY



WASTE WATER TREATMENT



CHEMICAL INDUSTRY



MINING INDUSTRY



CERAMIC INDUSTRY



RAFINERY



ADVANTAGES

- 1) Solid particles may pass through the pump.
- 2) It can work with an electric motor in environments where there is no or insufficient air.
- 3) Maintenance cost is low .
- 4) The flow rate can be controlled by connecting the driver to the electric motor of the pump.
- 5) The suction depth of this pump is 2 m.
- 6) It has the feature of working dry.

PUMP TECHNICAL SPECIFICATIONS

Max. Operating Pressure	: 2 bar
Voltage	: 380/220 volt 50 hz
Energy Consumption	: 0,55 kw
Displacement/Stroke	: 0,55 lt/strok
Max. Discharge Head	: 20 mss
Suction Head	: 2 m
Solid Particle Permeability	: 4 mm
Max. Capacity	: 4 m3/h 66.66 l/min
Reducer Speed	: 60 D/d
Max. Çalışma sıcaklığı	: 100 °C
Inlet	: 1 inch
Outlet	: 1 inch
Body Material	: Casting Iron
Diaphragm Options	: Santoprene, Neoprene, Buna-N, EPDM, Teflon, Viton
Ball Options	: Santoprene, Neoprene, Buna-N, EPDM, Teflon, Viton
Ball Seat Options	: Santoprene, Neoprene, Buna-N, EPDM, Teflon, Viton

DIAPHRAGM PUMPS PERFORMANCE CURVES

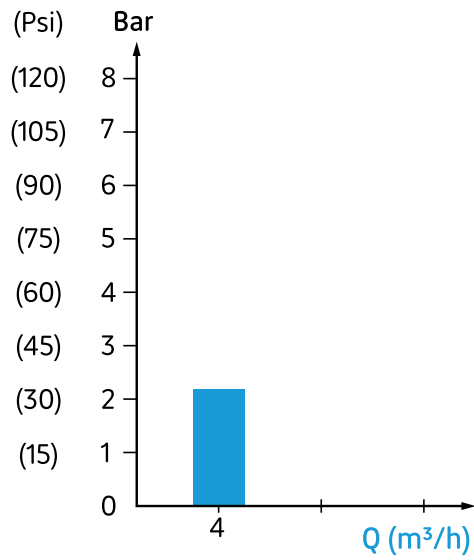

PUMP EXTERNAL DIMENSIONS

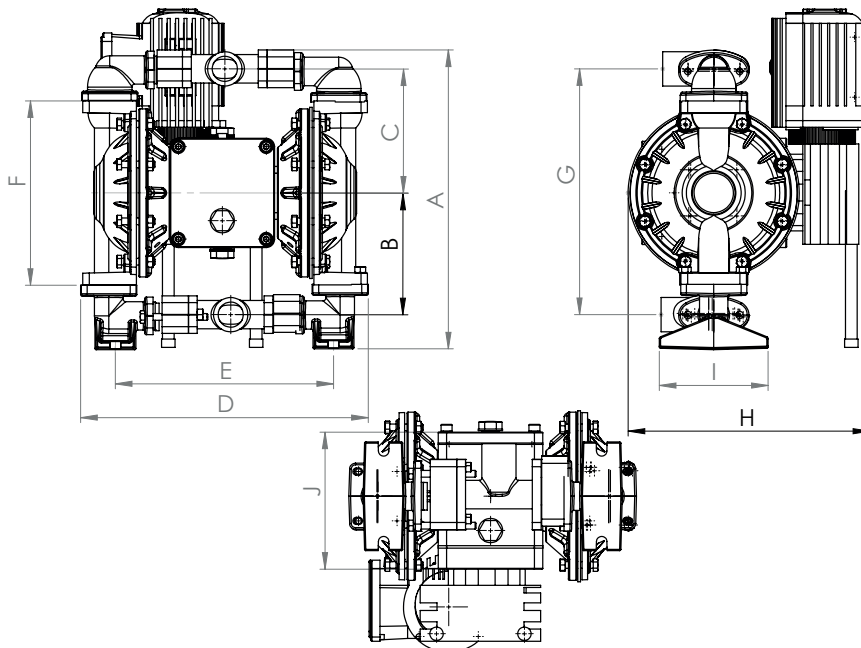

A	B	C	D	E	F	G	H	I	J
358	145	145	345	260	220	295	290	1301	163



APPLICATION AREAS

-  MEDICAL INDUSTRY
-  FOOD INDUSTRY
-  PAINT AND COATING INDUSTRY
-  WASTE WATER TREATMENT
-  CHEMICAL INDUSTRY
-  MINING INDUSTRY
-  CERAMIC INDUSTRY
-  RAFINERY

ADVANTAGES

- 1) Solid particles may pass through the pump.
- 2) It can work with an electric motor in environments where there is no or insufficient air.
- 3) Maintenance cost is low .
- 4) The flow rate can be controlled by connecting the driver to the electric motor of the pump.
- 5) The suction depth of this pump is 4 m.
- 6) It has the feature of working dry.

PUMP TECHNICAL SPECIFICATIONS

Max. Operating Pressure	: 4 bar
Voltage	: 380 volt 50 hz
Energy Consumption	: 2,2 kw / 3 kw / 4 kw
Displacement/Stroke	: 1,47 lt/strok
Max. Discharge Head	: 40 mss
Suction Head	: 4 m
Solid Particle Permeability	: 6 mm
Max. Capacity	: 13,8 m3/h 230 l/min
Reducer Speed	: 78 D/d
Max. Çalışma sıcaklığı	: 100 °C
Inlet	: 1½ inch
Outlet	: 1½ inch
Body Material	: Casting Iron
Diaphragm Options	: Santoprene, Neoprene, Buna-N, EPDM, Teflon, Viton
Ball Options	: Santoprene, Neoprene, Buna-N, EPDM, Teflon, Viton
Ball Seat Options	: Santoprene, Neoprene, Buna-N, EPDM, Teflon, Viton

DIAPHRAGM PUMPS PERFORMANCE CURVES

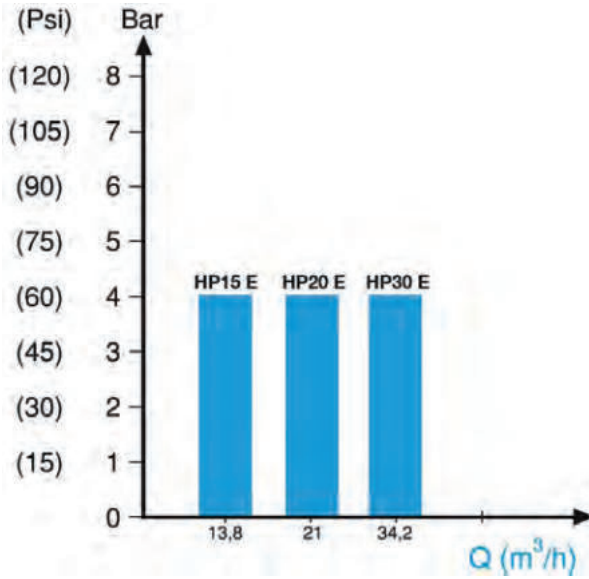

PUMP EXTERNAL DIMENSIONS

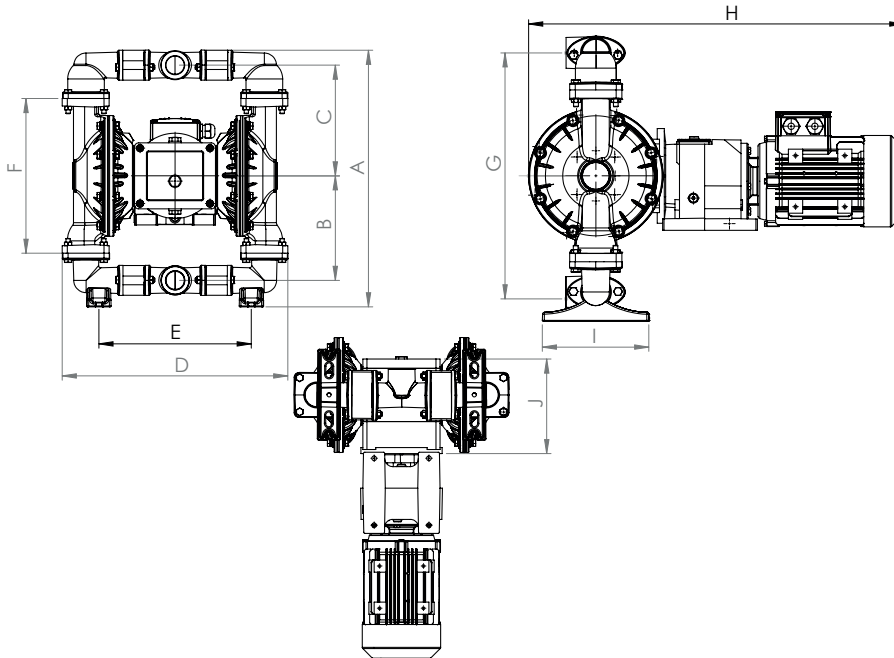

A	B	C	D	E	F	G	H	I	J
603	250	260	530	360	363	520	762	225	233



APPLICATION AREAS

-  MEDICAL INDUSTRY
-  FOOD INDUSTRY
-  PAINT AND COATING INDUSTRY
-  WASTE WATER TREATMENT
-  CHEMICAL INDUSTRY
-  MINING INDUSTRY
-  CERAMIC INDUSTRY
-  RAFINERY

ADVANTAGES

- 1) Solid particles may pass through the pump.
- 2) It can work with an electric motor in environments where there is no or insufficient air.
- 3) Maintenance cost is low .
- 4) The flow rate can be controlled by connecting the driver to the electric motor of the pump.
- 5) The suction depth of this pump is 4 m.
- 6) It has the feature of working dry.

PUMP TECHNICAL SPECIFICATIONS

Max. Operating Pressure	: 4 bar
Voltage	: 380 volt 50 hz
Energy Consumption	: 3kw / 4kw / 5,5 kw
Displacement/Stroke	: 2,24 lt/strok
Max. Discharge Head	: 40 mss
Suction Head	: 4 m
Solid Particle Permeability	: 6 mm
Max. Capacity	: 21 m3/h 350 l/min
Reducer Speed	: 78 D/d
Max. Çalışma sıcaklığı	: 100 °C
Inlet	: 2 inch
Outlet	: 2 inch
Body Material	: Casting Iron
Diaphragm Options	: Santoprene, Neoprene, Buna-N, EPDM, Teflon, Viton
Ball Options	: Santoprene, Neoprene, Buna-N, EPDM, Teflon, Viton
Ball Seat Options	: Santoprene, Neoprene, Buna-N, EPDM, Teflon, Viton

DIAPHRAGM PUMPS PERFORMANCE CURVES

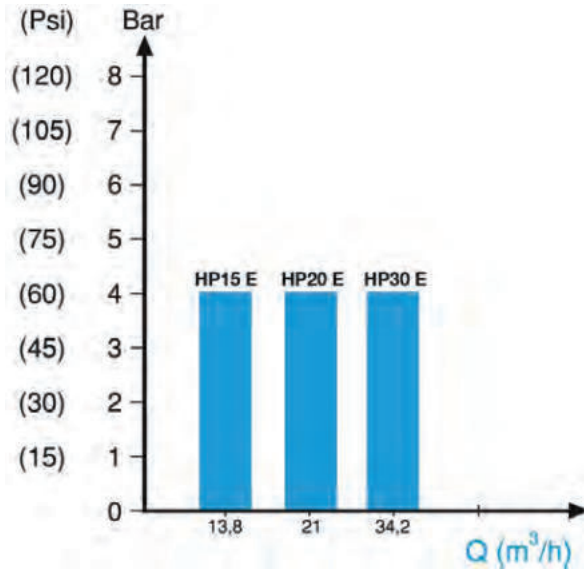

PUMP EXTERNAL DIMENSIONS

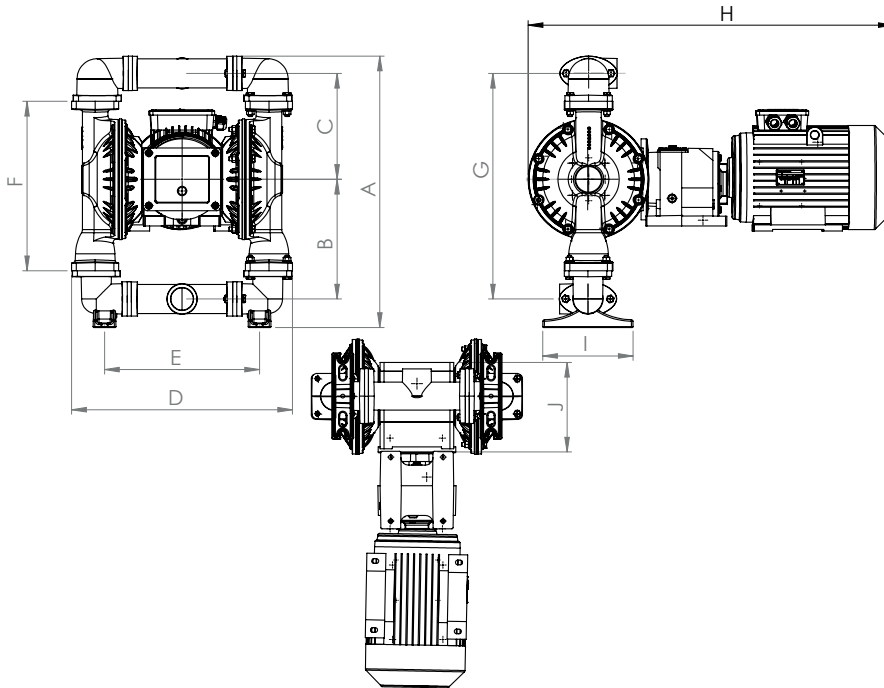

A	B	C	D	E	F	G	H	I	J
670	295	260	545	390	418	567	900	223	231



APPLICATION AREAS

-  MEDICAL INDUSTRY
-  FOOD INDUSTRY
-  PAINT AND COATING INDUSTRY
-  WASTE WATER TREATMENT
-  CHEMICAL INDUSTRY
-  MINING INDUSTRY
-  CERAMIC INDUSTRY
-  RAFINERY

ADVANTAGES

- 1) Solid particles may pass through the pump.
- 2) It can work with an electric motor in environments where there is no or insufficient air.
- 3) Maintenance cost is low .
- 4) The flow rate can be controlled by connecting the driver to the electric motor of the pump.
- 5) The suction depth of this pump is 4 m.
- 6) It has the feature of working dry.

PUMP TECHNICAL SPECIFICATIONS

Max. Operating Pressure	: 4 bar
Voltage	: 380 volt 50 hz
Energy Consumption	: 5,5kw / 7,5 kw
Displacement/Stroke	: 3,65 lt/strok
Max. Discharge Head	: 40 mss
Suction Head	: 4 m
Solid Particle Permeability	: 8 mm
Max. Capacity	: 34,2 m ³ /h 570 l/min
Reducer Speed	: 78 D/d
Max. Çalışma sıcaklığı	: 100 °C
Inlet	: 3 inch
Outlet	: 3 inch
Body Material	: Casting Iron
Diaphragm Options	: Santoprene, Neoprene, Buna-N, EPDM, Teflon, Viton
Ball Options	: Santoprene, Neoprene, Buna-N, EPDM, Teflon, Viton
Ball Seat Options	: Santoprene, Neoprene, Buna-N, EPDM, Teflon, Viton

DIAPHRAGM PUMPS PERFORMANCE CURVES

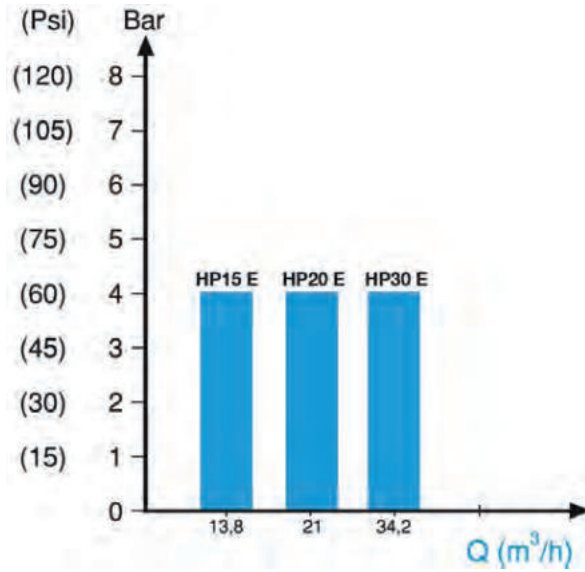

PUMP EXTERNAL DIMENSIONS

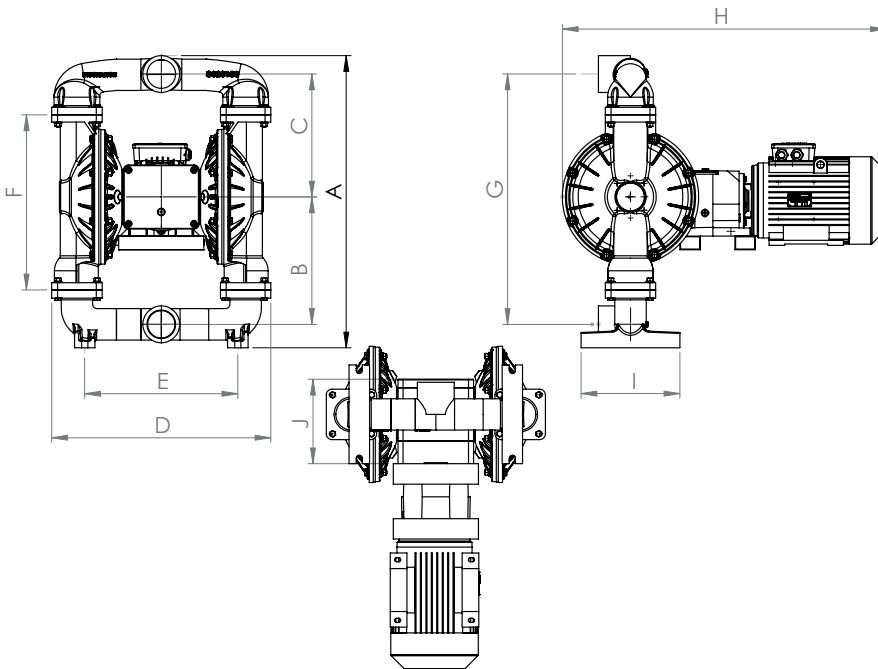

A	B	C	D	E	F	G	H	I	J
858	374	361	645	450	514	735	950	290	248

VP10 STAINLESS BODY ELECTRIC DIAPHRAGM PUMP

VESTA POMP
Makes life comfortable



APPLICATION AREAS

-  MEDICAL INDUSTRY
-  FOOD INDUSTRY
-  PAINT AND COATING INDUSTRY
-  WASTE WATER TREATMENT
-  CHEMICAL INDUSTRY
-  MINING INDUSTRY
-  CERAMIC INDUSTRY
-  RAFINERY

ADVANTAGES

- 1) Solid particles may pass through the pump.
- 2) It can work with an electric motor in environments where there is no or insufficient air.
- 3) Maintenance cost is low .
- 4) The flow rate can be controlled by connecting the driver to the electric motor of the pump.
- 5) The suction depth of this pump is 2 m.
- 6) It has the feature of working dry.

PUMP TECHNICAL SPECIFICATIONS

Max. Operating Pressure	: 2 bar
Voltage	: 380/220 volt 50 hz
Energy Consumption	: 0,55 kw
Displacement/Stroke	: 0,55 lt/strok
Max. Discharge Head	: 20 mss
Suction Head	: 2 m
Solid Particle Permeability	: 4 mm
Max. Capacity	: 4 m3/h 66.66 l/min
Reducer Speed	: 60 D/d
Max. Çalışma sıcaklığı	: 100 °C
Inlet	: 1 inch
Outlet	: 1 inch
Body Material	: Stainless Steel
Diaphragm Options	: Santoprene, Neoprene, Buna-N, EPDM, Teflon, Viton
Ball Options	: Santoprene, Neoprene, Buna-N, EPDM, Teflon, Viton
Ball Seat Options	: Santoprene, Neoprene, Buna-N, EPDM, Teflon, Viton

DIAPHRAGM PUMPS PERFORMANCE CURVES

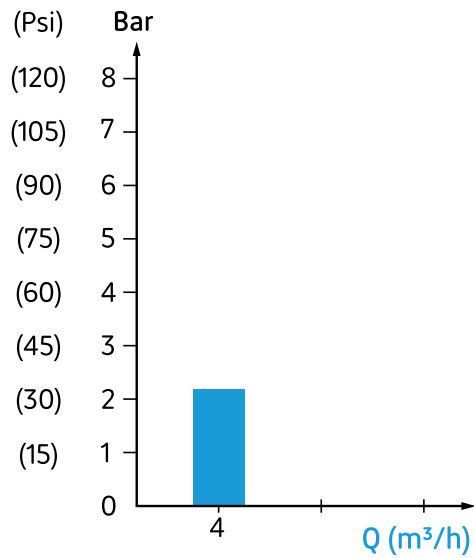

PUMP EXTERNAL DIMENSIONS

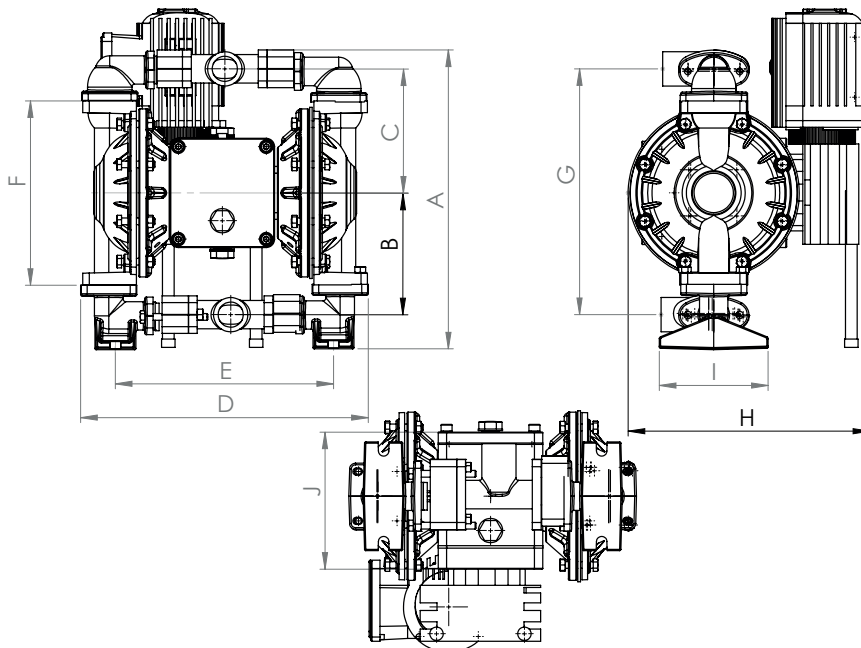

A	B	C	D	E	F	G	H	I	J
358	145	145	345	260	220	295	290	1301	163

VP15 STAINLESS BODY ELECTRIC DIAPHRAGM PUMP

VESTA POMP
Makes life comfortable



APPLICATION AREAS

-  MEDICAL INDUSTRY
-  FOOD INDUSTRY
-  PAINT AND COATING INDUSTRY
-  WASTE WATER TREATMENT
-  CHEMICAL INDUSTRY
-  MINING INDUSTRY
-  CERAMIC INDUSTRY
-  RAFINERY

ADVANTAGES

- 1) Solid particles may pass through the pump.
- 2) It can work with an electric motor in environments where there is no or insufficient air.
- 3) Maintenance cost is low .
- 4) The flow rate can be controlled by connecting the driver to the electric motor of the pump.
- 5) The suction depth of this pump is 4 m.
- 6) It has the feature of working dry.

PUMP TECHNICAL SPECIFICATIONS

Max. Operating Pressure	: 4 bar
Voltage	: 380 volt 50 hz
Energy Consumption	: 2,2 kw / 3 kw / 4 kw
Displacement/Stroke	: 1,47 lt/strok
Max. Discharge Head	: 40 mss
Suction Head	: 4 m
Solid Particle Permeability	: 6 mm
Max. Capacity	: 13,8 m3/h 230 l/min
Reducer Speed	: 78 D/d
Max. Çalışma sıcaklığı	: 100 °C
Inlet	: 1½ inch
Outlet	: 1½ inch
Body Material	: Stainless Steel
Diaphragm Options	: Santoprene, Neoprene, Buna-N, EPDM, Teflon, Viton
Ball Options	: Santoprene, Neoprene, Buna-N, EPDM, Teflon, Viton
Ball Seat Options	: Santoprene, Neoprene, Buna-N, EPDM, Teflon, Viton

DIAPHRAGM PUMPS PERFORMANCE CURVES

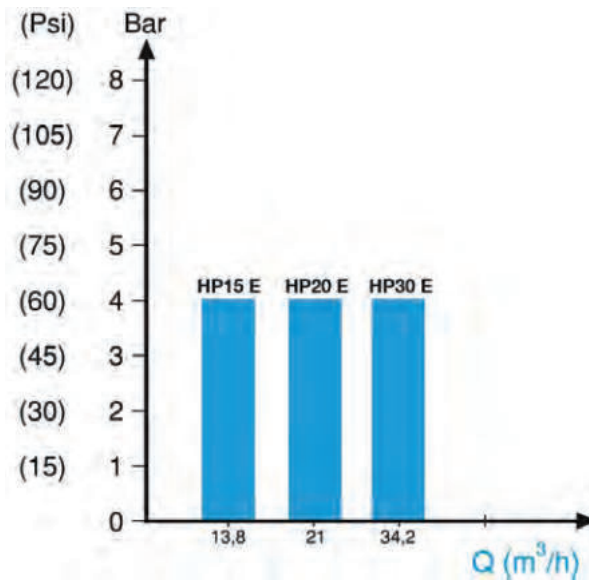

PUMP EXTERNAL DIMENSIONS

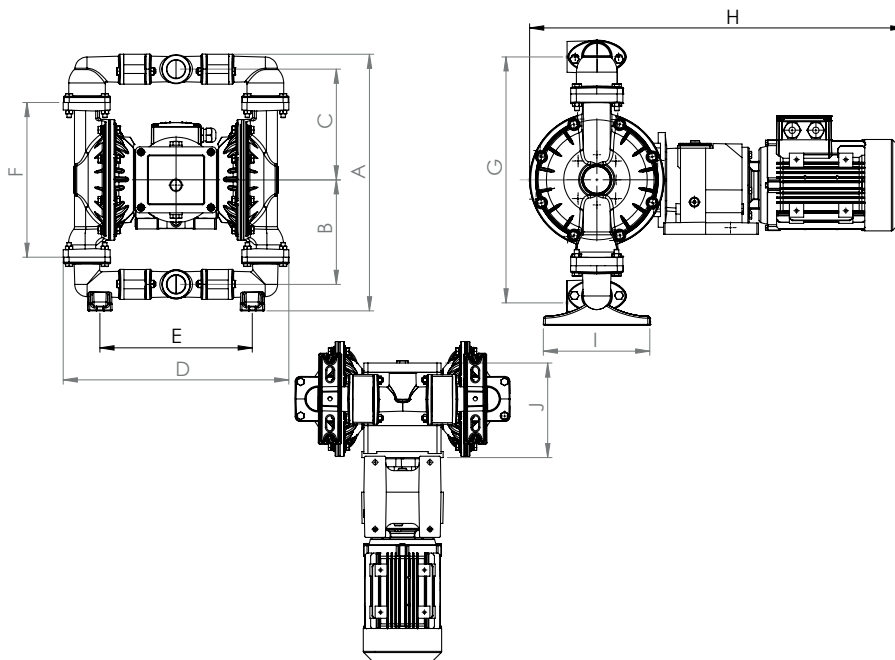

A	B	C	D	E	F	G	H	I	J
603	250	260	530	360	363	520	762	225	233

VP20 STAINLESS BODY ELECTRIC DIAPHRAGM PUMP

VESTA POMP
Makes life comfortable



APPLICATION AREAS

-  MEDICAL INDUSTRY
-  FOOD INDUSTRY
-  PAINT AND COATING INDUSTRY
-  WASTE WATER TREATMENT
-  CHEMICAL INDUSTRY
-  MINING INDUSTRY
-  CERAMIC INDUSTRY
-  RAFINERY

ADVANTAGES

- 1) Solid particles may pass through the pump.
- 2) It can work with an electric motor in environments where there is no or insufficient air.
- 3) Maintenance cost is low .
- 4) The flow rate can be controlled by connecting the driver to the electric motor of the pump.
- 5) The suction depth of this pump is 4 m.
- 6) It has the feature of working dry.

PUMP TECHNICAL SPECIFICATIONS

Max. Operating Pressure	: 4 bar
Voltage	: 380 volt 50 hz
Energy Consumption	: 3kw / 4kw / 5,5 kw
Displacement/Stroke	: 2,24 lt/strok
Max. Discharge Head	: 40 mss
Suction Head	: 4 m
Solid Particle Permeability	: 6 mm
Max. Capacity	: 21 m3/h 350 l/min
Reducer Speed	: 78 D/d
Max. Çalışma sıcaklığı	: 100 °C
Inlet	: 2 inch
Outlet	: 2 inch
Body Material	: Stainless Steel
Diaphragm Options	: Santoprene, Neoprene, Buna-N, EPDM, Teflon, Viton
Ball Options	: Santoprene, Neoprene, Buna-N, EPDM, Teflon, Viton
Ball Seat Options	: Santoprene, Neoprene, Buna-N, EPDM, Teflon, Viton

DIAPHRAGM PUMPS PERFORMANCE CURVES

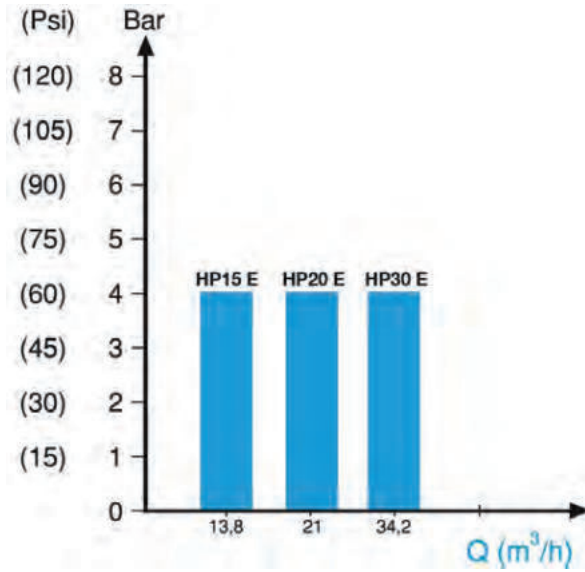

PUMP EXTERNAL DIMENSIONS

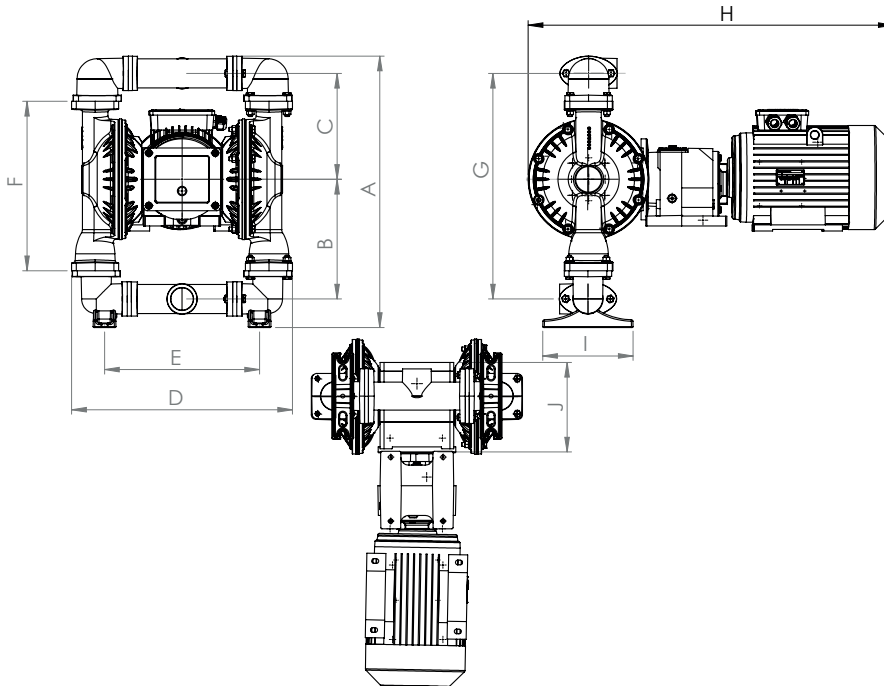

A	B	C	D	E	F	G	H	I	J
670	295	260	545	390	418	567	900	223	231

VP30 STAINLESS BODY ELECTRIC DIAPHRAGM PUMP

VESTA POMP
Makes life comfortable



APPLICATION AREAS

-  MEDICAL INDUSTRY
-  FOOD INDUSTRY
-  PAINT AND COATING INDUSTRY
-  WASTE WATER TREATMENT
-  CHEMICAL INDUSTRY
-  MINING INDUSTRY
-  CERAMIC INDUSTRY
-  RAFINERY

ADVANTAGES

- 1) Solid particles may pass through the pump.
- 2) It can work with an electric motor in environments where there is no or insufficient air.
- 3) Maintenance cost is low .
- 4) The flow rate can be controlled by connecting the driver to the electric motor of the pump.
- 5) The suction depth of this pump is 4 m.
- 6) It has the feature of working dry.

PUMP TECHNICAL SPECIFICATIONS

Max. Operating Pressure	: 4 bar
Voltage	: 380 volt 50 hz
Energy Consumption	: 5,5kw / 7,5 kw
Displacement/Stroke	: 3,65 lt/strok
Max. Discharge Head	: 40 mss
Suction Head	: 4 m
Solid Particle Permeability	: 8 mm
Max. Capacity	: 34,2 m3/h 570 l/min
Reducer Speed	: 78 D/d
Max. Çalışma sıcaklığı	: 100 °C
Inlet	: 3 inch
Outlet	: 3 inch
Body Material	: Stainless Steel
Diaphragm Options	: Santoprene, Neoprene, Buna-N, EPDM, Teflon, Viton
Ball Options	: Santoprene, Neoprene, Buna-N, EPDM, Teflon, Viton
Ball Seat Options	: Santoprene, Neoprene, Buna-N, EPDM, Teflon, Viton

DIAPHRAGM PUMPS PERFORMANCE CURVES

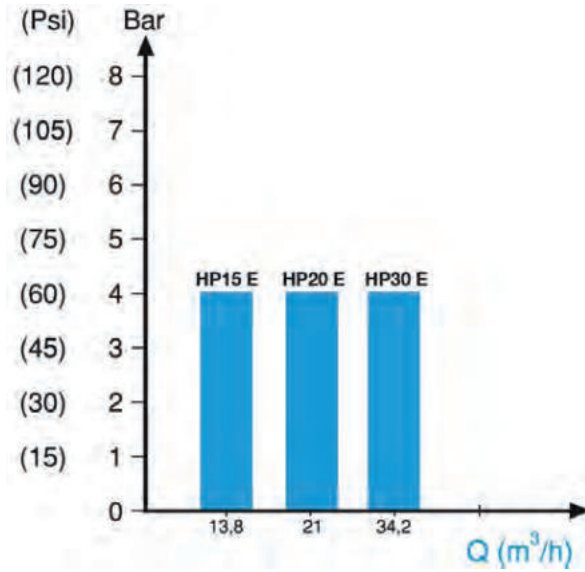

PUMP EXTERNAL DIMENSIONS

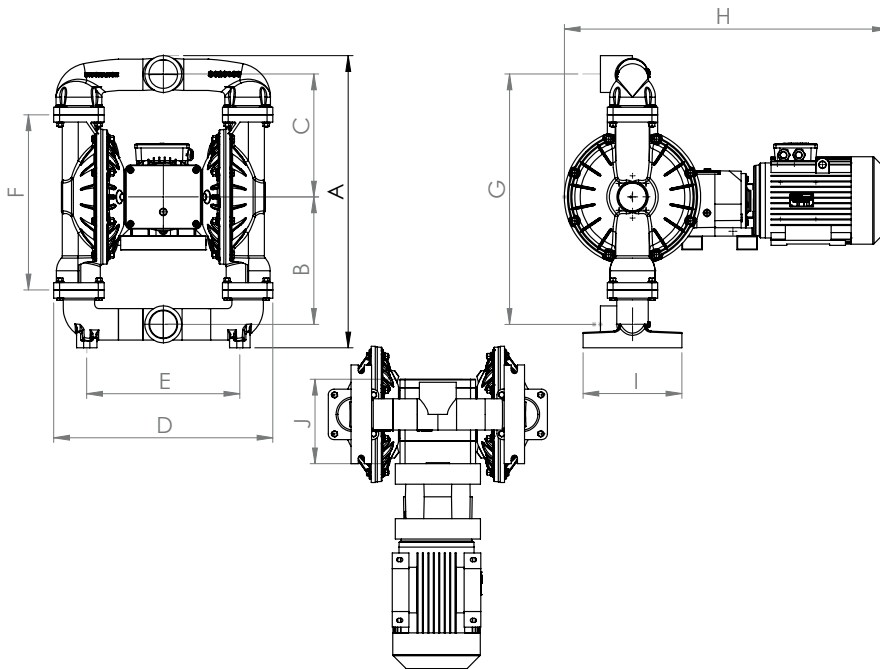

A	B	C	D	E	F	G	H	I	J
858	374	361	645	450	514	735	950	290	248



APPLICATION AREAS

-  MEDICAL INDUSTRY
-  FOOD INDUSTRY
-  PAINT AND COATING INDUSTRY
-  WASTE WATER TREATMENT
-  CHEMICAL INDUSTRY
-  MINING INDUSTRY
-  CERAMIC INDUSTRY
-  RAFINERY

ADVANTAGES

- 1) Solid particles may pass through the pump.
- 2) It can work with an electric motor in environments where there is no or insufficient air.
- 3) Maintenance cost is low .
- 4) The flow rate can be controlled by connecting the driver to the electric motor of the pump.
- 5) The suction depth of this pump is 2 m.
- 6) It has the feature of working dry.

PUMP TECHNICAL SPECIFICATIONS

Max. Operating Pressure	: 2 bar
Voltage	: 380/220 volt 50 hz
Energy Consumption	: 0,25 kw
Displacement/Stroke	: 0,2 lt/strok
Max. Discharge Head	: 20 mss
Suction Head	: 2 m
Solid Particle Permeability	: 3 mm
Max. Capacity	: 1,48 m3/h 24.6 l/min
Reducer Speed	: 60 D/d
Max. Çalışma sıcaklığı	: 100 °C
Inlet	: 3/4 inch
Outlet	: 3/4 inch
Body Material	: PB (Glass fiber added polypropylene)
Diaphragm Options	: Santoprene, Neoprene, Buna-N, EPDM, Teflon, Viton
Ball Options	: Santoprene, Neoprene, Buna-N, EPDM, Teflon, Viton
Ball Seat Options	: Santoprene, Neoprene, Buna-N, EPDM, Teflon, Viton

DIAPHRAGM PUMPS PERFORMANCE CURVES

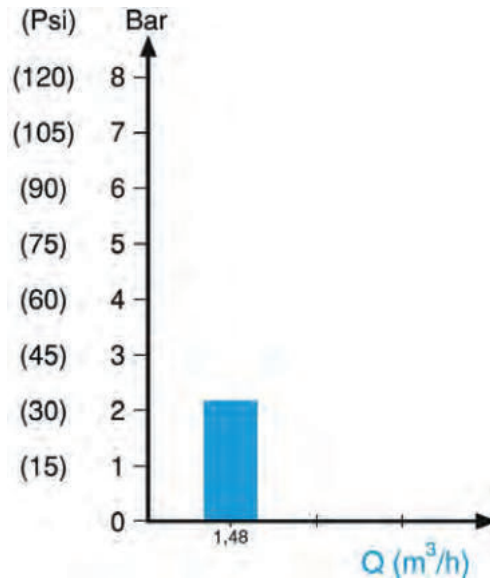

PUMP EXTERNAL DIMENSIONS

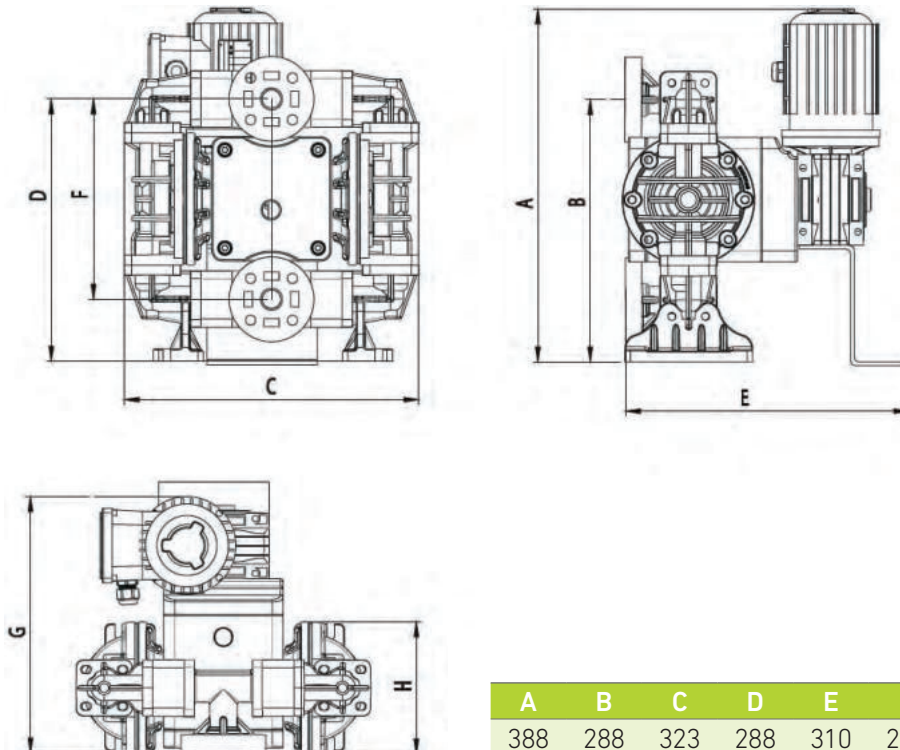



APPLICATION AREAS

-  MEDICAL INDUSTRY
-  FOOD INDUSTRY
-  PAINT AND COATING INDUSTRY
-  WASTE WATER TREATMENT
-  CHEMICAL INDUSTRY
-  MINING INDUSTRY
-  CERAMIC INDUSTRY
-  RAFINERY

ADVANTAGES

- 1) Solid particles may pass through the pump.
- 2) It can work with an electric motor in environments where there is no or insufficient air.
- 3) Maintenance cost is low .
- 4) The flow rate can be controlled by connecting the driver to the electric motor of the pump.
- 5) The suction depth of this pump is 2 m.
- 6) It has the feature of working dry.

PUMP TECHNICAL SPECIFICATIONS

Max. Operating Pressure	: 2 bar
Voltage	: 380/220 volt 50 hz
Energy Consumption	: 0,55 kw
Displacement/Stroke	: 0,55 lt/strok
Max. Discharge Head	: 20 mss
Suction Head	: 2 m
Solid Particle Permeability	: 4 mm
Max. Capacity	: 4 m3/h 66.66 l/min
Reducer Speed	: 60 D/d
Max. Çalışma sıcaklığı	: 100 °C
Inlet	: 1 inch
Outlet	: 1 inch
Body Material	: PB (Glass fiber added polypropylene)
Diaphragm Options	: Santoprene, Neoprene, Buna-N, EPDM, Teflon, Viton
Ball Options	: Santoprene, Neoprene, Buna-N, EPDM, Teflon, Viton
Ball Seat Options	: Santoprene, Neoprene, Buna-N, EPDM, Teflon, Viton

DIAPHRAGM PUMPS PERFORMANCE CURVES

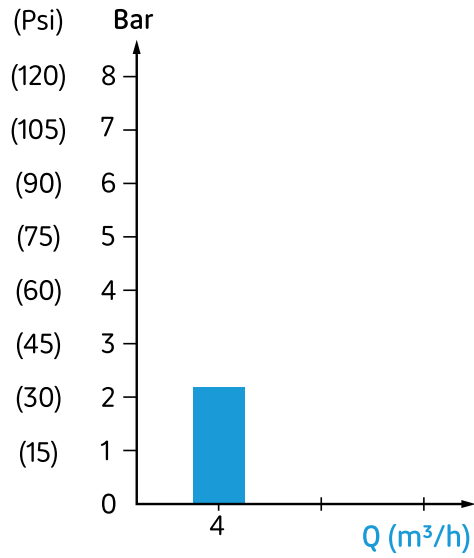

PUMP EXTERNAL DIMENSIONS

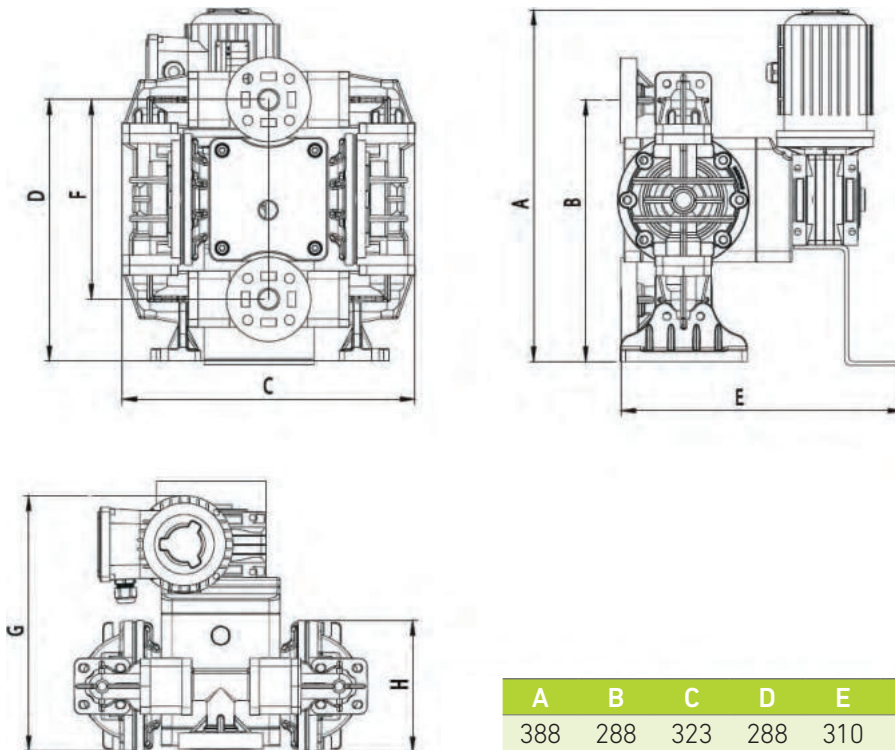



APPLICATION AREAS

-  MEDICAL INDUSTRY
-  FOOD INDUSTRY
-  PAINT AND COATING INDUSTRY
-  WASTE WATER TREATMENT
-  CHEMICAL INDUSTRY
-  MINING INDUSTRY
-  CERAMIC INDUSTRY
-  RAFINERY

ADVANTAGES

- 1) Solid particles may pass through the pump.
- 2) It can work with an electric motor in environments where there is no or insufficient air.
- 3) Maintenance cost is low .
- 4) The flow rate can be controlled by connecting the driver to the electric motor of the pump.
- 5) The suction depth of this pump is 4 m.
- 6) It has the feature of working dry.

PUMP TECHNICAL SPECIFICATIONS

Max. Operating Pressure	: 4 bar
Voltage	: 380 volt 50 hz
Energy Consumption	: 2,2 kw / 3 kw / 4 kw
Displacement/Stroke	: 1,47 lt/strok
Max. Discharge Head	: 40 mss
Suction Head	: 4 m
Solid Particle Permeability	: 6 mm
Max. Capacity	: 13,8 m3/h 230 l/min
Reducer Speed	: 78 D/d
Max. Çalışma sıcaklığı	: 100 °C
Inlet	: 1½ inch
Outlet	: 1½ inch
Body Material	: PB (Glass fiber added polypropylene)
Diaphragm Options	: Santoprene, Neoprene, Buna-N, EPDM, Teflon, Viton
Ball Options	: Santoprene, Neoprene, Buna-N, EPDM, Teflon, Viton
Ball Seat Options	: Santoprene, Neoprene, Buna-N, EPDM, Teflon, Viton

DIAPHRAGM PUMPS PERFORMANCE CURVES

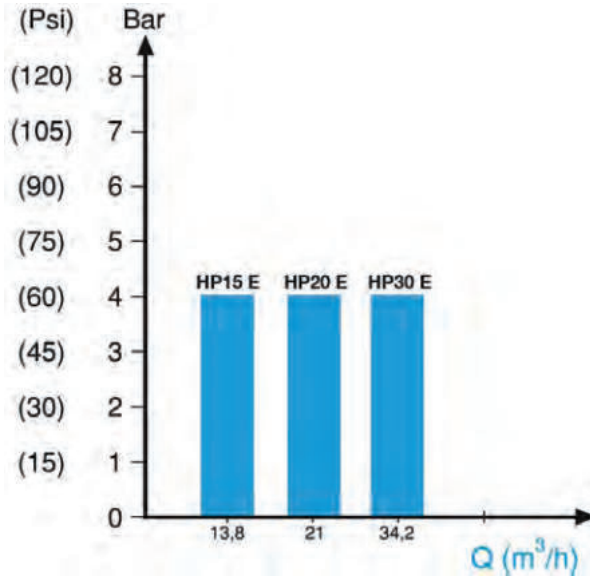

PUMP EXTERNAL DIMENSIONS

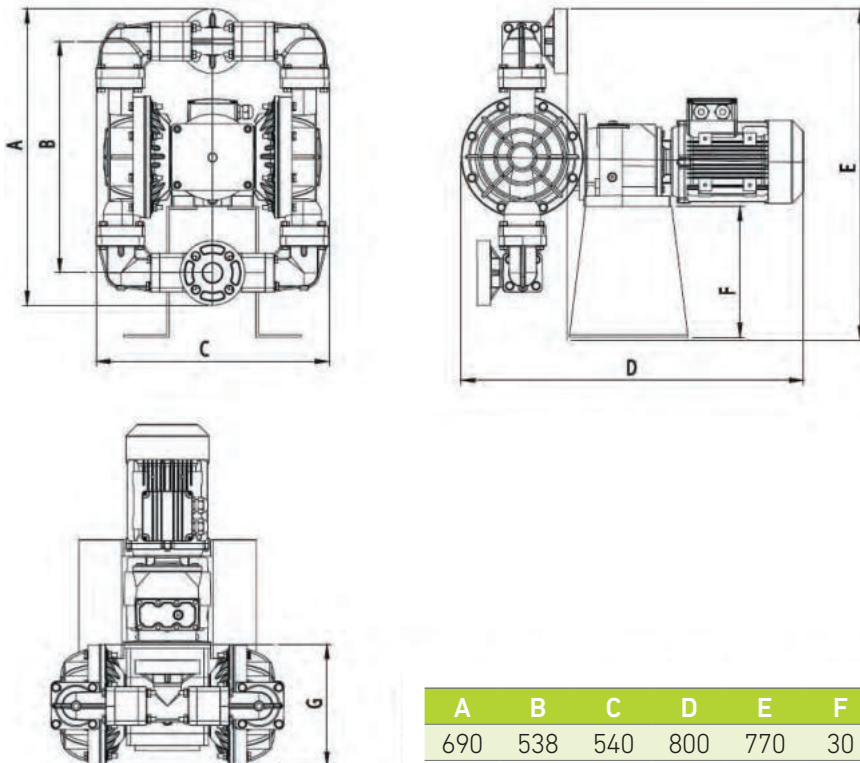



APPLICATION AREAS

-  MEDICAL INDUSTRY
-  FOOD INDUSTRY
-  PAINT AND COATING INDUSTRY
-  WASTE WATER TREATMENT
-  CHEMICAL INDUSTRY
-  MINING INDUSTRY
-  CERAMIC INDUSTRY
-  RAFINERY

ADVANTAGES

- 1) Solid particles may pass through the pump.
- 2) It can work with an electric motor in environments where there is no or insufficient air.
- 3) Maintenance cost is low .
- 4) The flow rate can be controlled by connecting the driver to the electric motor of the pump.
- 5) The suction depth of this pump is 4 m.
- 6) It has the feature of working dry.

PUMP TECHNICAL SPECIFICATIONS

Max. Operating Pressure	: 4 bar
Voltage	: 380 volt 50 hz
Energy Consumption	: 3kw / 4kw / 5,5 kw
Displacement/Stroke	: 2,24 lt/strok
Max. Discharge Head	: 40 mss
Suction Head	: 4 m
Solid Particle Permeability	: 6 mm
Max. Capacity	: 21 m ³ /h 350 l/min
Reducer Speed	: 78 D/d
Max. Çalışma sıcaklığı	: 100 °C
Inlet	: 2 inch
Outlet	: 2 inch
Body Material	: PB (Glass fiber added polypropylene)
Diaphragm Options	: Santoprene, Neoprene, Buna-N, EPDM, Teflon, Viton
Ball Options	: Santoprene, Neoprene, Buna-N, EPDM, Teflon, Viton
Ball Seat Options	: Santoprene, Neoprene, Buna-N, EPDM, Teflon, Viton

DIAPHRAGM PUMPS PERFORMANCE CURVES

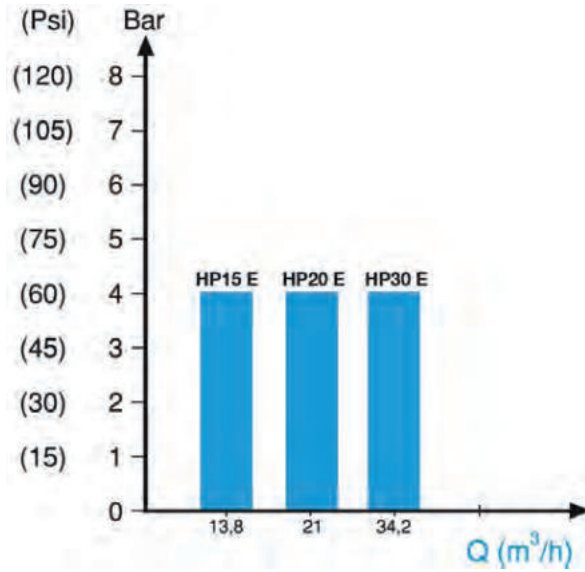

PUMP EXTERNAL DIMENSIONS

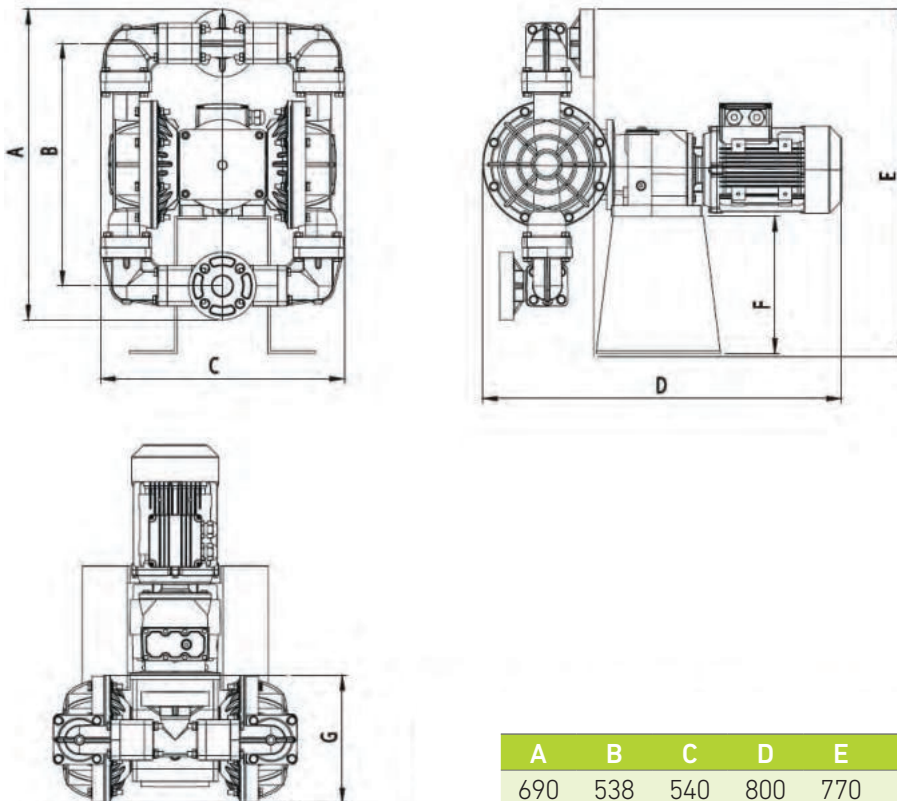

APPLICATION AREAS

-  MEDICAL INDUSTRY
-  FOOD INDUSTRY
-  PAINT AND COATING INDUSTRY
-  WASTE WATER TREATMENT
-  CHEMICAL INDUSTRY
-  MINING INDUSTRY
-  CERAMIC INDUSTRY
-  RAFINERY



ADVANTAGES

- 1) Solid particles may pass through the pump.
- 2) It can work with an electric motor in environments where there is no or insufficient air.
- 3) Maintenance cost is low .
- 4) The flow rate can be controlled by connecting the driver to the electric motor of the pump.
- 5) The suction depth of this pump is 4 m.
- 6) It has the feature of working dry.

PUMP TECHNICAL SPECIFICATIONS

Max. Operating Pressure	: 4 bar
Voltage	: 380 volt 50 hz
Energy Consumption	: 5,5kw / 7,5 kw
Displacement/Stroke	: 3,65 lt/strok
Max. Discharge Head	: 40 mss
Suction Head	: 4 m
Solid Particle Permeability	: 8 mm
Max. Capacity	: 34,2 m3/h 570 l/min
Reducer Speed	: 78 D/d
Max. Çalışma sıcaklığı	: 100 °C
Inlet	: 3 inch
Outlet	: 3 inch
Body Material	: PB (Glass fiber added polypropylene)
Diaphragm Options	: Santoprene, Neoprene, Buna-N, EPDM, Teflon, Viton
Ball Options	: Santoprene, Neoprene, Buna-N, EPDM, Teflon, Viton
Ball Seat Options	: Santoprene, Neoprene, Buna-N, EPDM, Teflon, Viton

DIAPHRAGM PUMPS PERFORMANCE CURVES

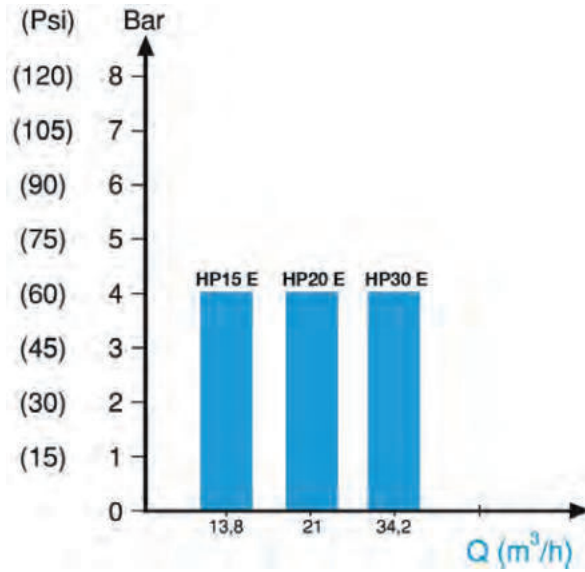

PUMP EXTERNAL DIMENSIONS

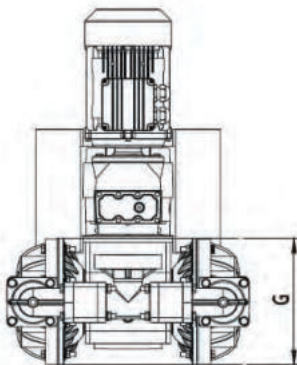
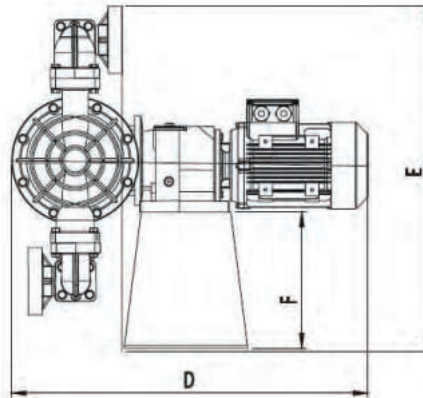
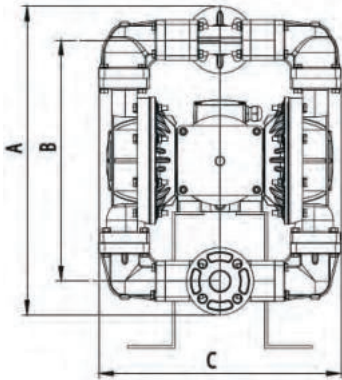

A	B	C	D	E	F	G
690	538	540	800	770	30	283

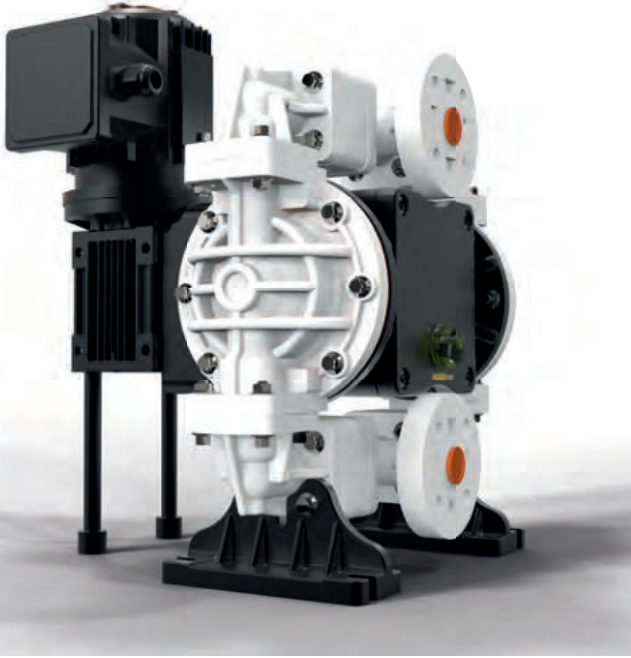

APPLICATION AREAS

-  MEDICAL INDUSTRY
-  FOOD INDUSTRY
-  PAINT AND COATING INDUSTRY
-  WASTE WATER TREATMENT
-  CHEMICAL INDUSTRY
-  MINING INDUSTRY
-  CERAMIC INDUSTRY
-  RAFINERY

ADVANTAGES

- 1) Solid particles may pass through the pump.
- 2) It can work with an electric motor in environments where there is no or insufficient air.
- 3) Maintenance cost is low .
- 4) The flow rate can be controlled by connecting the driver to the electric motor of the pump.
- 5) The suction depth of this pump is 2 m.
- 6) It has the feature of working dry.

PUMP TECHNICAL SPECIFICATIONS

Max. Operating Pressure	: 2 bar
Voltage	: 380/220 volt 50 hz
Energy Consumption	: 0,25 kw
Displacement/Stroke	: 0,2 lt/strok
Max. Discharge Head	: 20 mss
Suction Head	: 2 m
Solid Particle Permeability	: 3 mm
Max. Capacity	: 1,48 m3/h 24.6 l/min
Reducer Speed	: 60 D/d
Max. Çalışma sıcaklığı	: 100 °C
Inlet	: 3/4 inch
Outlet	: 3/4 inch
Body Material	: Polipropilen
Diaphragm Options	: Santoprene, Neoprene, Buna-N, EPDM, Teflon, Viton
Ball Options	: Santoprene, Neoprene, Buna-N, EPDM, Teflon, Viton
Ball Seat Options	: Santoprene, Neoprene, Buna-N, EPDM, Teflon, Viton

DIAPHRAGM PUMPS PERFORMANCE CURVES

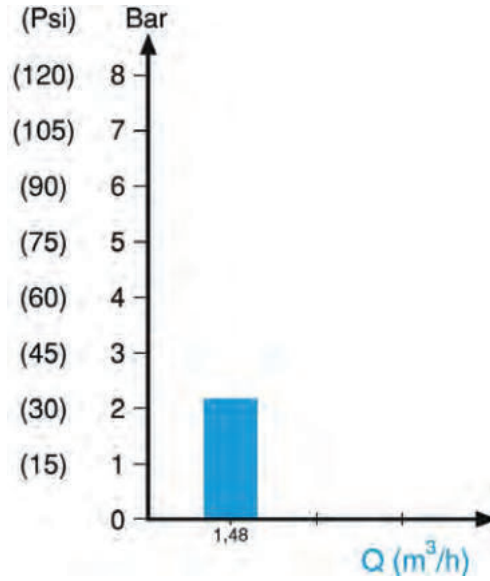

PUMP EXTERNAL DIMENSIONS

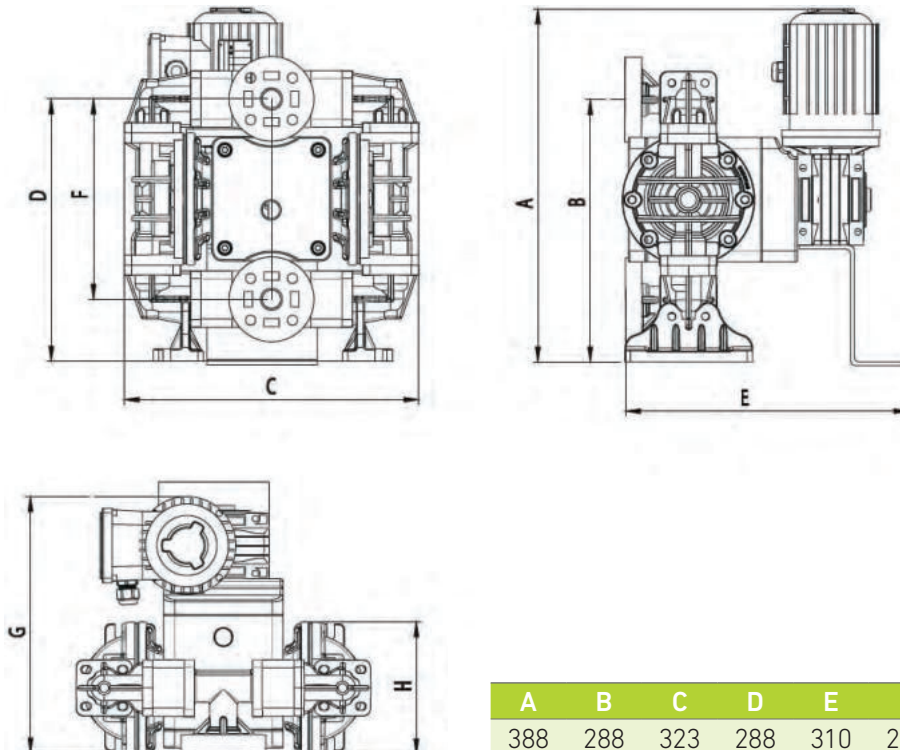



APPLICATION AREAS

-  MEDICAL INDUSTRY
-  FOOD INDUSTRY
-  PAINT AND COATING INDUSTRY
-  WASTE WATER TREATMENT
-  CHEMICAL INDUSTRY
-  MINING INDUSTRY
-  CERAMIC INDUSTRY
-  RAFINERY

ADVANTAGES

- 1) Solid particles may pass through the pump.
- 2) It can work with an electric motor in environments where there is no or insufficient air.
- 3) Maintenance cost is low .
- 4) The flow rate can be controlled by connecting the driver to the electric motor of the pump.
- 5) The suction depth of this pump is 2 m.
- 6) It has the feature of working dry.

PUMP TECHNICAL SPECIFICATIONS

Max. Operating Pressure	: 2 bar
Voltage	: 380/220 volt 50 hz
Energy Consumption	: 0,55 kw
Displacement/Stroke	: 0,55 lt/strok
Max. Discharge Head	: 20 mss
Suction Head	: 2 m
Solid Particle Permeability	: 4 mm
Max. Capacity	: 4 m3/h 66.66 l/min
Reducer Speed	: 60 D/d
Max. Çalışma sıcaklığı	: 100 °C
Inlet	: 1 inch
Outlet	: 1 inch
Body Material	: Polipropilen
Diaphragm Options	: Santoprene, Neoprene, Buna-N, EPDM, Teflon, Viton
Ball Options	: Santoprene, Neoprene, Buna-N, EPDM, Teflon, Viton
Ball Seat Options	: Santoprene, Neoprene, Buna-N, EPDM, Teflon, Viton

DIAPHRAGM PUMPS PERFORMANCE CURVES

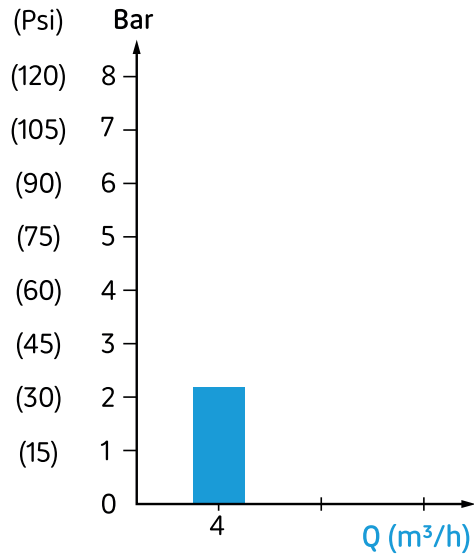

PUMP EXTERNAL DIMENSIONS

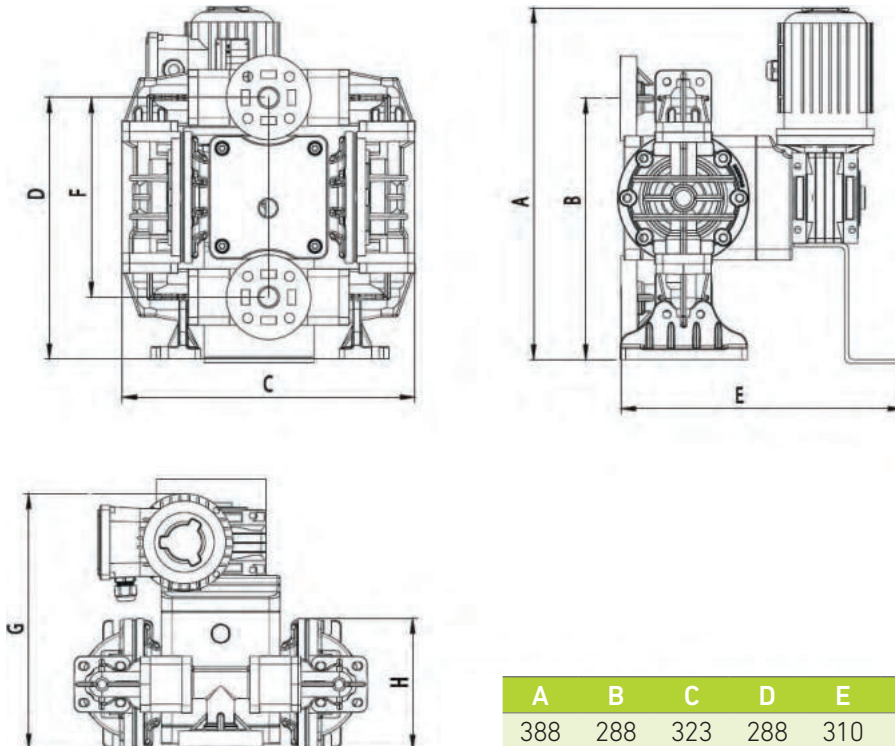

APPLICATION AREAS

-  MEDICAL INDUSTRY
-  FOOD INDUSTRY
-  PAINT AND COATING INDUSTRY
-  WASTE WATER TREATMENT
-  CHEMICAL INDUSTRY
-  MINING INDUSTRY
-  CERAMIC INDUSTRY
-  RAFINERY



ADVANTAGES

- 1) Solid particles may pass through the pump.
- 2) It can work with an electric motor in environments where there is no or insufficient air.
- 3) Maintenance cost is low .
- 4) The flow rate can be controlled by connecting the driver to the electric motor of the pump.
- 5) The suction depth of this pump is 4 m.
- 6) It has the feature of working dry.

PUMP TECHNICAL SPECIFICATIONS

Max. Operating Pressure	: 4 bar
Voltage	: 380 volt 50 hz
Energy Consumption	: 2,2 kw / 3 kw / 4 kw
Displacement/Stroke	: 1,47 lt/strok
Max. Discharge Head	: 40 mss
Suction Head	: 4 m
Solid Particle Permeability	: 6 mm
Max. Capacity	: 13,8 m3/h 230 l/min
Reducer Speed	: 78 D/d
Max. Çalışma sıcaklığı	: 100 °C
Inlet	: 1½ inch
Outlet	: 1½ inch
Body Material	: Polipropilen
Diaphragm Options	: Santoprene, Neoprene, Buna-N, EPDM, Teflon, Viton
Ball Options	: Santoprene, Neoprene, Buna-N, EPDM, Teflon, Viton
Ball Seat Options	: Santoprene, Neoprene, Buna-N, EPDM, Teflon, Viton

DIAPHRAGM PUMPS PERFORMANCE CURVES

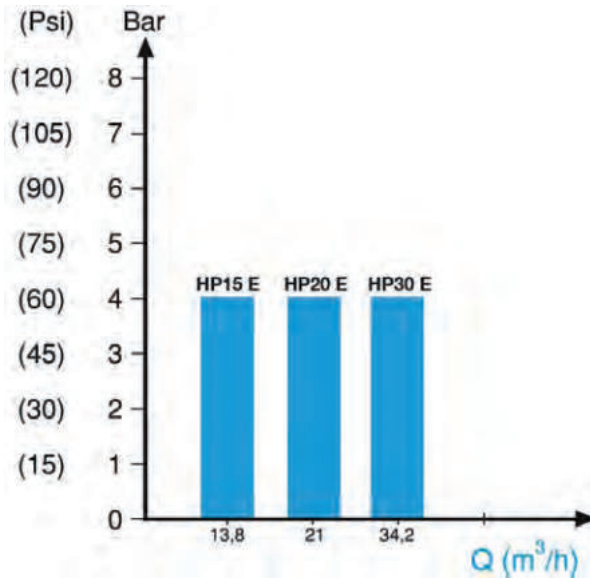

PUMP EXTERNAL DIMENSIONS

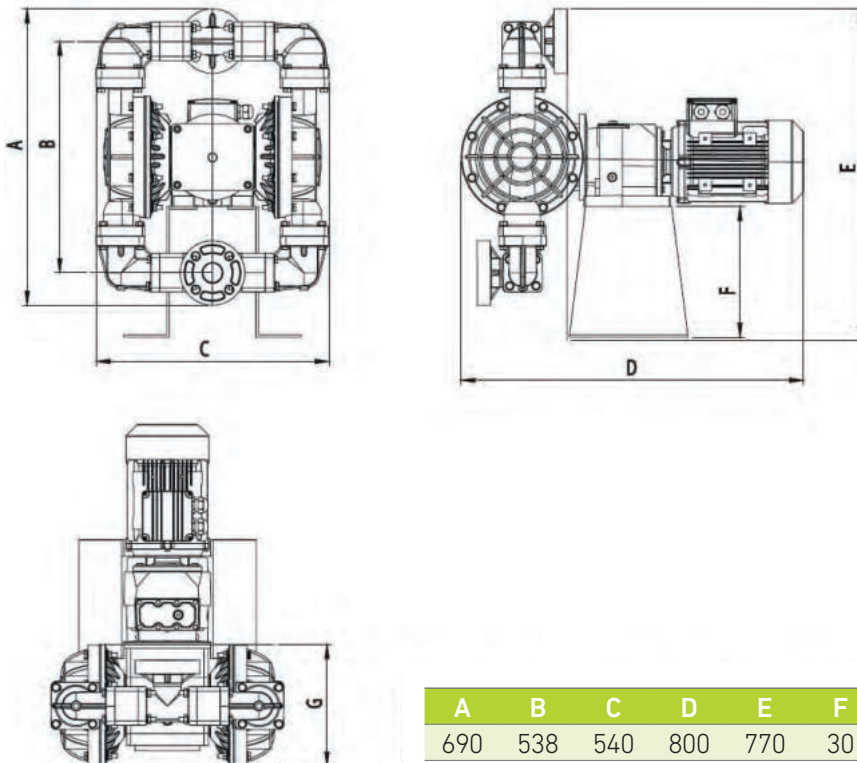



APPLICATION AREAS

-  MEDICAL INDUSTRY
-  FOOD INDUSTRY
-  PAINT AND COATING INDUSTRY
-  WASTE WATER TREATMENT
-  CHEMICAL INDUSTRY
-  MINING INDUSTRY
-  CERAMIC INDUSTRY
-  RAFINERY

ADVANTAGES

- 1) Solid particles may pass through the pump.
- 2) It can work with an electric motor in environments where there is no or insufficient air.
- 3) Maintenance cost is low .
- 4) The flow rate can be controlled by connecting the driver to the electric motor of the pump.
- 5) The suction depth of this pump is 4 m.
- 6) It has the feature of working dry.

PUMP TECHNICAL SPECIFICATIONS

Max. Operating Pressure	: 4 bar
Voltage	: 380 volt 50 hz
Energy Consumption	: 3kw / 4kw / 5,5 kw
Displacement/Stroke	: 2,24 lt/strok
Max. Discharge Head	: 40 mss
Suction Head	: 4 m
Solid Particle Permeability	: 6 mm
Max. Capacity	: 21 m ³ /h 350 l/min
Reducer Speed	: 78 D/d
Max. Çalışma sıcaklığı	: 100 °C
Inlet	: 2 inch
Outlet	: 2 inch
Body Material	: Polipropilen
Diaphragm Options	: Santoprene, Neoprene, Buna-N, EPDM, Teflon, Viton
Ball Options	: Santoprene, Neoprene, Buna-N, EPDM, Teflon, Viton
Ball Seat Options	: Santoprene, Neoprene, Buna-N, EPDM, Teflon, Viton

DIAPHRAGM PUMPS PERFORMANCE CURVES

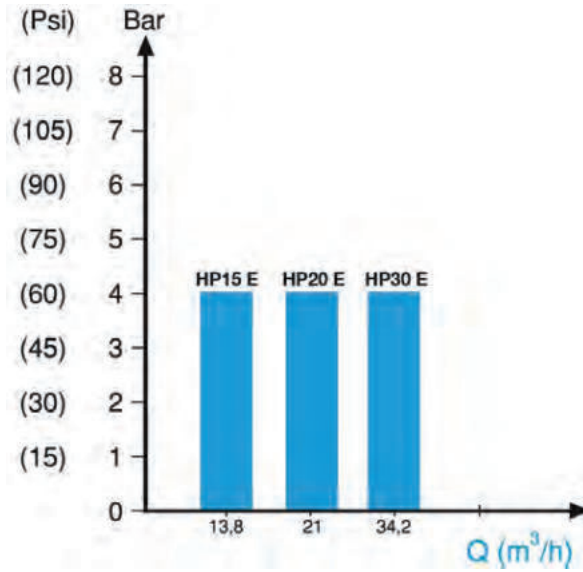

PUMP EXTERNAL DIMENSIONS

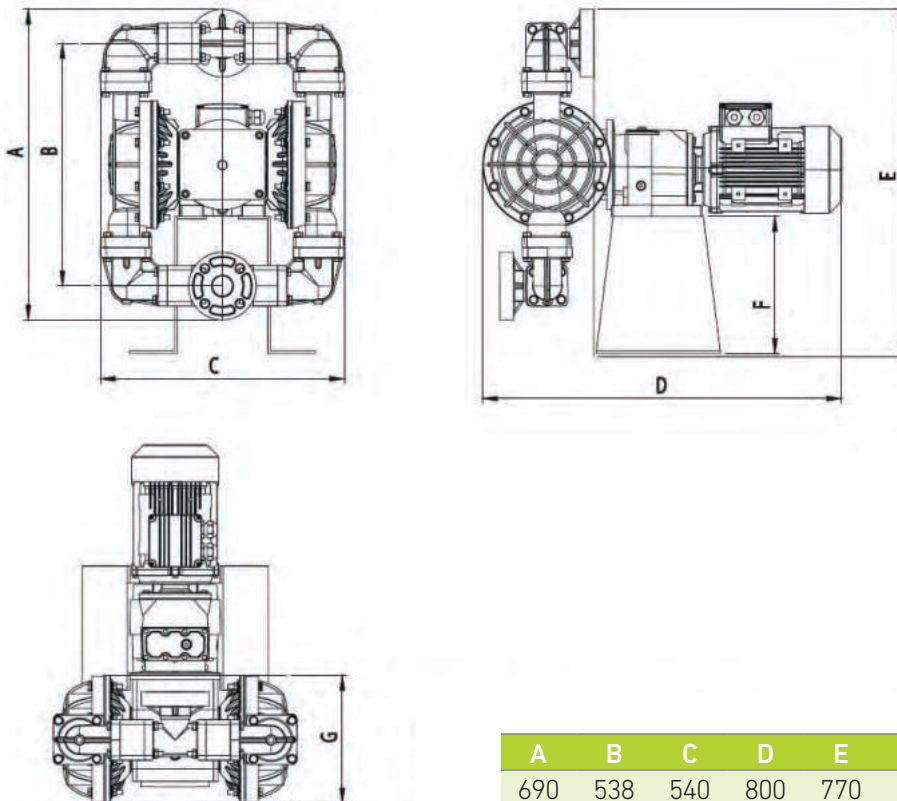

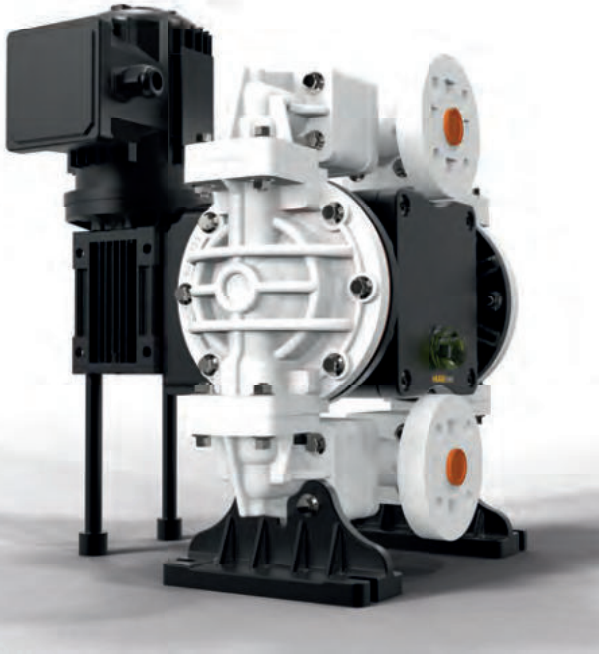

APPLICATION AREAS

-  MEDICAL INDUSTRY
-  FOOD INDUSTRY
-  PAINT AND COATING INDUSTRY
-  WASTE WATER TREATMENT
-  CHEMICAL INDUSTRY
-  MINING INDUSTRY
-  CERAMIC INDUSTRY
-  RAFINERY

ADVANTAGES

- 1) Solid particles may pass through the pump.
- 2) It can work with an electric motor in environments where there is no or insufficient air.
- 3) Maintenance cost is low .
- 4) The flow rate can be controlled by connecting the driver to the electric motor of the pump.
- 5) The suction depth of this pump is 2 m.
- 6) It has the feature of working dry.

PUMP TECHNICAL SPECIFICATIONS

Max. Operating Pressure	: 2 bar
Voltage	: 380/220 volt 50 hz
Energy Consumption	: 0,25 kw
Displacement/Stroke	: 0,2 lt/strok
Max. Discharge Head	: 20 mss
Suction Head	: 2 m
Solid Particle Permeability	: 3 mm
Max. Capacity	: 1,48 m3/h 24.6 l/min
Reducer Speed	: 60 D/d
Max. Çalışma sıcaklığı	: 100 °C
Inlet	: 3/4 inch
Outlet	: 3/4 inch
Body Material	: PVDF
Diaphragm Options	: Santoprene, Neoprene, Buna-N, EPDM, Teflon, Viton
Ball Options	: Santoprene, Neoprene, Buna-N, EPDM, Teflon, Viton
Ball Seat Options	: Santoprene, Neoprene, Buna-N, EPDM, Teflon, Viton

DIAPHRAGM PUMPS PERFORMANCE CURVES

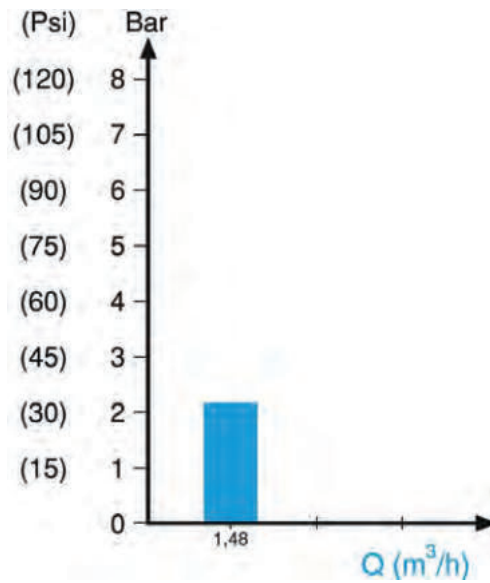

PUMP EXTERNAL DIMENSIONS

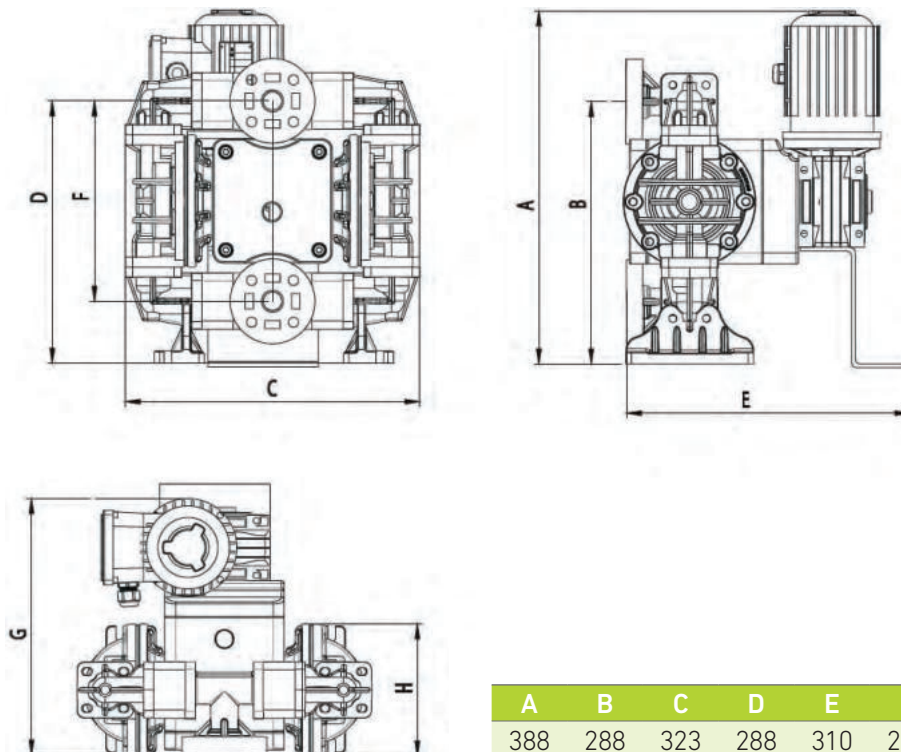



APPLICATION AREAS

-  MEDICAL INDUSTRY
-  FOOD INDUSTRY
-  PAINT AND COATING INDUSTRY
-  WASTE WATER TREATMENT
-  CHEMICAL INDUSTRY
-  MINING INDUSTRY
-  CERAMIC INDUSTRY
-  RAFINERY

ADVANTAGES

- 1) Solid particles may pass through the pump.
- 2) It can work with an electric motor in environments where there is no or insufficient air.
- 3) Maintenance cost is low .
- 4) The flow rate can be controlled by connecting the driver to the electric motor of the pump.
- 5) The suction depth of this pump is 2 m.
- 6) It has the feature of working dry.

PUMP TECHNICAL SPECIFICATIONS

Max. Operating Pressure	: 2 bar
Voltage	: 380/220 volt 50 hz
Energy Consumption	: 0,55 kw
Displacement/Stroke	: 0,55 lt/strok
Max. Discharge Head	: 20 mss
Suction Head	: 2 m
Solid Particle Permeability	: 4 mm
Max. Capacity	: 4 m3/h 66.66 l/min
Reducer Speed	: 60 D/d
Max. Çalışma sıcaklığı	: 100 °C
Inlet	: 1 inch
Outlet	: 1 inch
Body Material	: PVDF
Diaphragm Options	: Santoprene, Neoprene, Buna-N, EPDM, Teflon, Viton
Ball Options	: Santoprene, Neoprene, Buna-N, EPDM, Teflon, Viton
Ball Seat Options	: Santoprene, Neoprene, Buna-N, EPDM, Teflon, Viton

DIAPHRAGM PUMPS PERFORMANCE CURVES

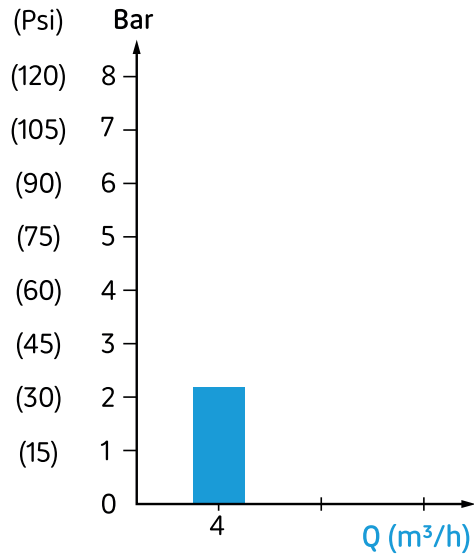

PUMP EXTERNAL DIMENSIONS

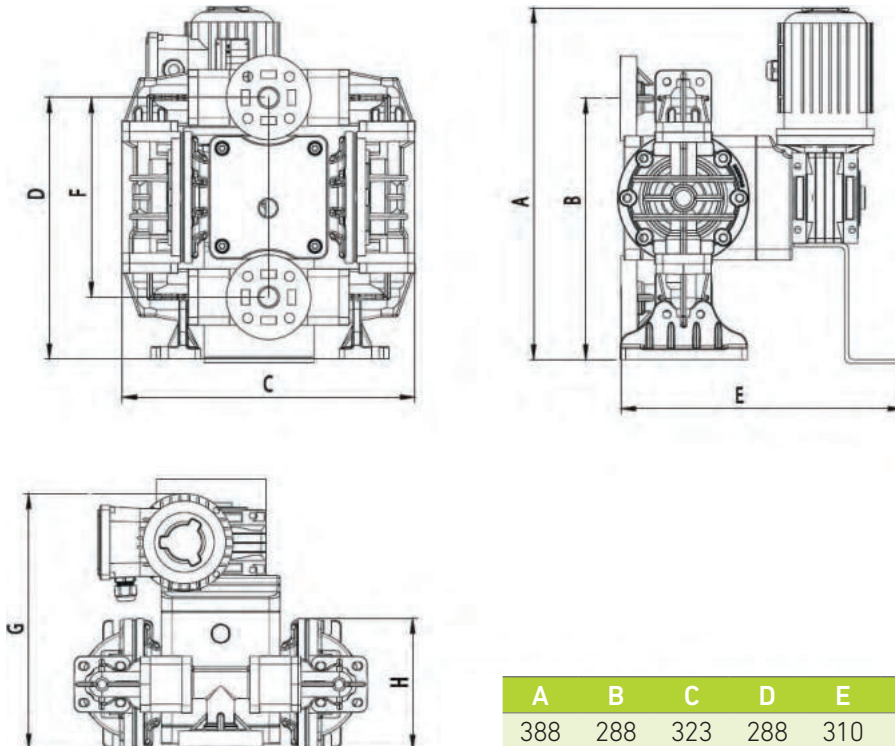

APPLICATION AREAS

-  MEDICAL INDUSTRY
-  FOOD INDUSTRY
-  PAINT AND COATING INDUSTRY
-  WASTE WATER TREATMENT
-  CHEMICAL INDUSTRY
-  MINING INDUSTRY
-  CERAMIC INDUSTRY
-  RAFINERY



ADVANTAGES

- 1) Solid particles may pass through the pump.
- 2) It can work with an electric motor in environments where there is no or insufficient air.
- 3) Maintenance cost is low .
- 4) The flow rate can be controlled by connecting the driver to the electric motor of the pump.
- 5) The suction depth of this pump is 4 m.
- 6) It has the feature of working dry.

PUMP TECHNICAL SPECIFICATIONS

Max. Operating Pressure	: 4 bar
Voltage	: 380 volt 50 hz
Energy Consumption	: 2,2 kw / 3 kw / 4 kw
Displacement/Stroke	: 1,47 lt/strok
Max. Discharge Head	: 40 mss
Suction Head	: 4 m
Solid Particle Permeability	: 6 mm
Max. Capacity	: 13,8 m3/h 230 l/min
Reducer Speed	: 78 D/d
Max. Çalışma sıcaklığı	: 100 °C
Inlet	: 1½ inch
Outlet	: 1½ inch
Body Material	: PVDF
Diaphragm Options	: Santoprene, Neoprene, Buna-N, EPDM, Teflon, Viton
Ball Options	: Santoprene, Neoprene, Buna-N, EPDM, Teflon, Viton
Ball Seat Options	: Santoprene, Neoprene, Buna-N, EPDM, Teflon, Viton

DIAPHRAGM PUMPS PERFORMANCE CURVES

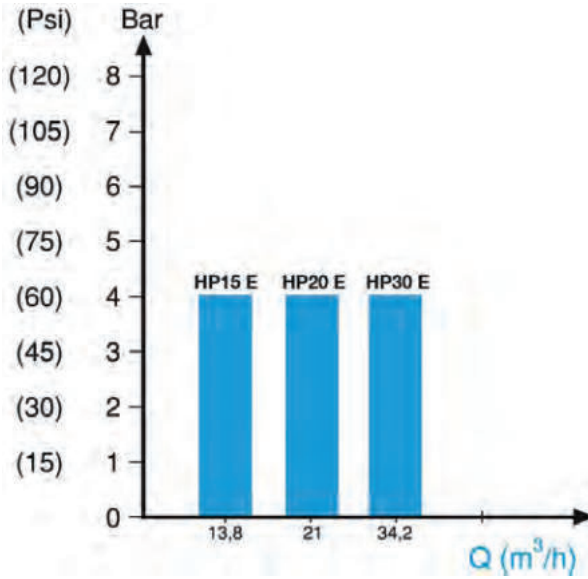

PUMP EXTERNAL DIMENSIONS

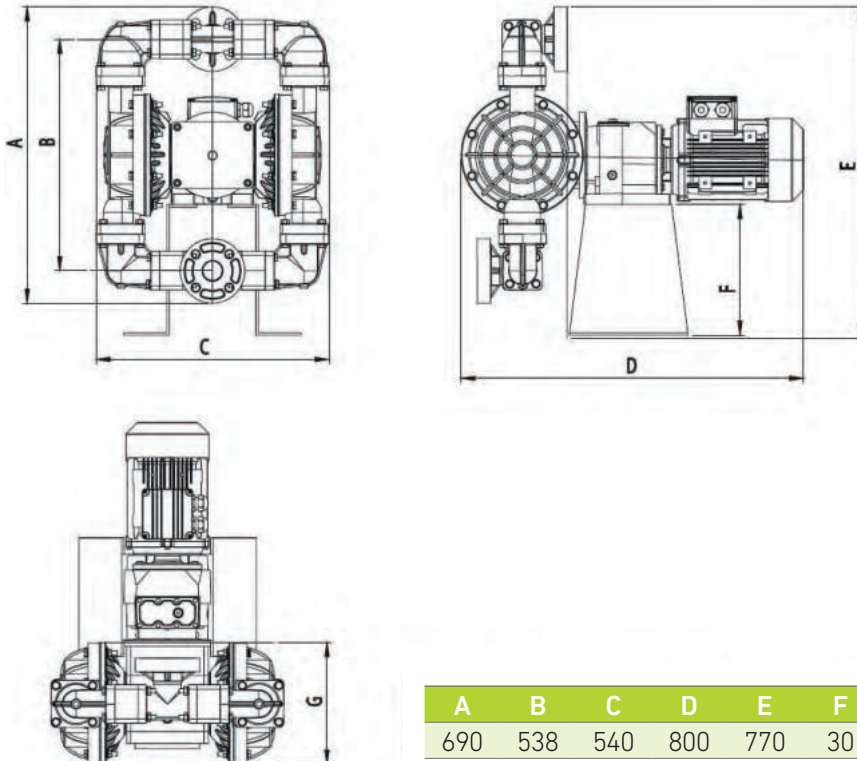



APPLICATION AREAS

-  MEDICAL INDUSTRY
-  FOOD INDUSTRY
-  PAINT AND COATING INDUSTRY
-  WASTE WATER TREATMENT
-  CHEMICAL INDUSTRY
-  MINING INDUSTRY
-  CERAMIC INDUSTRY
-  RAFINERY

ADVANTAGES

- 1) Solid particles may pass through the pump.
- 2) It can work with an electric motor in environments where there is no or insufficient air.
- 3) Maintenance cost is low .
- 4) The flow rate can be controlled by connecting the driver to the electric motor of the pump.
- 5) The suction depth of this pump is 4 m.
- 6) It has the feature of working dry.

PUMP TECHNICAL SPECIFICATIONS

Max. Operating Pressure	: 4 bar
Voltage	: 380 volt 50 hz
Energy Consumption	: 3kw / 4kw / 5,5 kw
Displacement/Stroke	: 2,24 lt/strok
Max. Discharge Head	: 40 mss
Suction Head	: 4 m
Solid Particle Permeability:	6 mm
Max. Capacity	: 21 m ³ /h 350 l/min
Reducer Speed	: 78 D/d
Max. Çalışma sıcaklığı	: 100 °C
Inlet	: 2 inch
Outlet	: 2 inch
Body Material	: PVDF
Diaphragm Options	: Santoprene, Neoprene, Buna-N, EPDM, Teflon, Viton
Ball Options	: Santoprene, Neoprene, Buna-N, EPDM, Teflon, Viton
Ball Seat Options	: Santoprene, Neoprene, Buna-N, EPDM, Teflon, Viton

DIAPHRAGM PUMPS PERFORMANCE CURVES

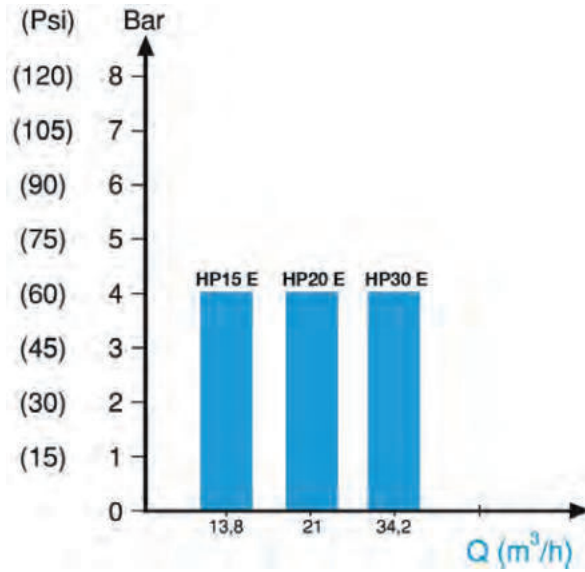

PUMP EXTERNAL DIMENSIONS

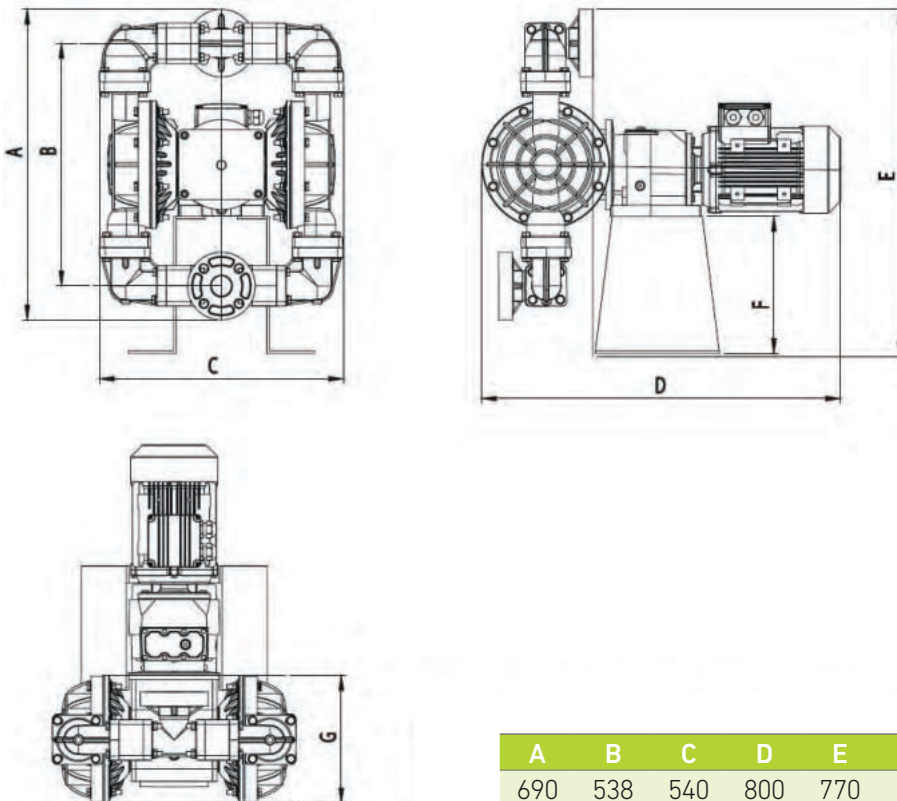



APPLICATION AREAS

-  MEDICAL INDUSTRY
-  FOOD INDUSTRY
-  PAINT AND COATING INDUSTRY
-  WASTE WATER TREATMENT
-  CHEMICAL INDUSTRY
-  MINING INDUSTRY
-  CERAMIC INDUSTRY
-  RAFINERY

ADVANTAGES

- 1) Solid particles may pass through the pump.
- 2) It can work with an electric motor in environments where there is no or insufficient air.
- 3) Maintenance cost is low .
- 4) The flow rate can be controlled by connecting the driver to the electric motor of the pump.
- 5) The suction depth of this pump is 4 m.
- 6) It has the feature of working dry.

PUMP TECHNICAL SPECIFICATIONS

Max. Operating Pressure	: 4 bar
Voltage	: 380 volt 50 hz
Energy Consumption	: 5,5kw / 7,5 kw
Displacement/Stroke	: 3,65 lt/strok
Max. Discharge Head	: 40 mss
Suction Head	: 4 m
Solid Particle Permeability	: 8 mm
Max. Capacity	: 34,2 m3/h 570 l/min
Reducer Speed	: 78 D/d
Max. Çalışma sıcaklığı	: 100 °C
Inlet	: 3 inch
Outlet	: 3 inch
Body Material	: PVDF
Diaphragm Options	: Santoprene, Neoprene, Buna-N, EPDM, Teflon, Viton
Ball Options	: Santoprene, Neoprene, Buna-N, EPDM, Teflon, Viton
Ball Seat Options	: Santoprene, Neoprene, Buna-N, EPDM, Teflon, Viton

DIAPHRAGM PUMPS PERFORMANCE CURVES

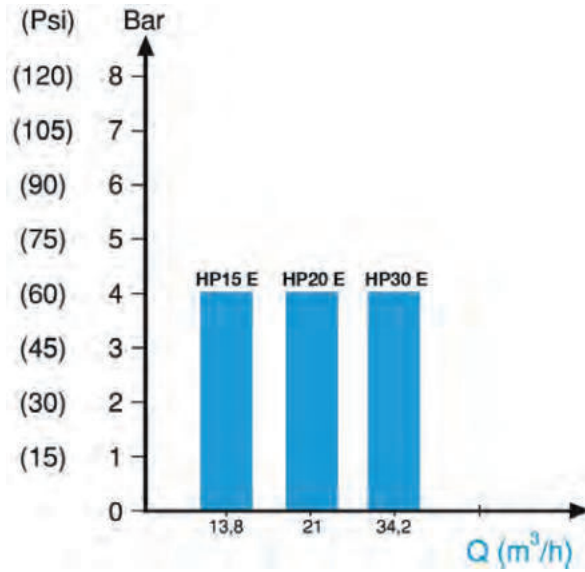

PUMP EXTERNAL DIMENSIONS

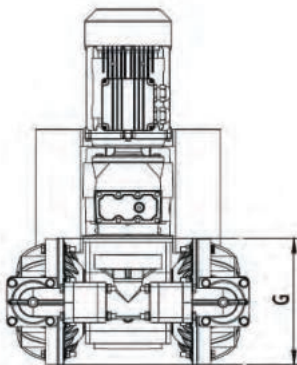
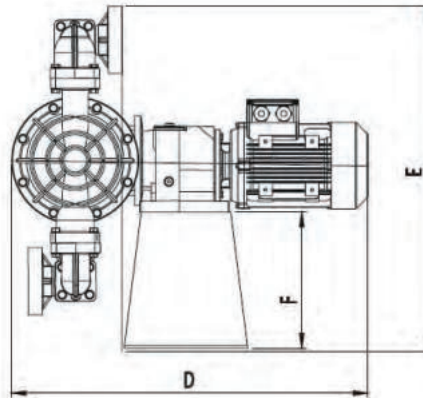
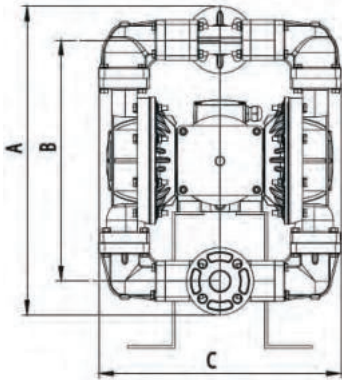

A	B	C	D	E	F	G
690	538	540	800	770	30	283



APPLICATION AREAS

-  MEDICAL INDUSTRY
-  FOOD INDUSTRY
-  PAINT AND COATING INDUSTRY
-  WASTE WATER TREATMENT
-  CHEMICAL INDUSTRY
-  MINING INDUSTRY
-  CERAMIC INDUSTRY
-  RAFINERY

ADVANTAGES

- 1) Solid particles may pass through the pump.
- 2) It can work with an electric motor in environments where there is no or insufficient air.
- 3) Maintenance cost is low .
- 4) The flow rate can be controlled by connecting the driver to the electric motor of the pump.
- 5) The suction depth of this pump is 2 m.
- 6) It has the feature of working dry.

PUMP TECHNICAL SPECIFICATIONS

Max. Operating Pressure	: 2 bar
Voltage	: 380/220 volt 50 hz
Energy Consumption	: 0,25 kw
Displacement/Stroke	: 0,2 lt/strok
Max. Discharge Head	: 20 mss
Suction Head	: 2 m
Solid Particle Permeability	: 3 mm
Max. Capacity	: 1,48 m3/h 24.6 l/min
Reducer Speed	: 60 D/d
Max. Çalışma sıcaklığı	: 100 °C
Inlet	: 3/4 inch
Outlet	: 3/4 inch
Body Material	: Sheet Stainless
Diaphragm Options	: Santoprene, Neoprene, Buna-N, EPDM, Teflon, Viton
Ball Options	: Santoprene, Neoprene, Buna-N, EPDM, Teflon, Viton
Ball Seat Options	: Santoprene, Neoprene, Buna-N, EPDM, Teflon, Viton

DIAPHRAGM PUMPS PERFORMANCE CURVES

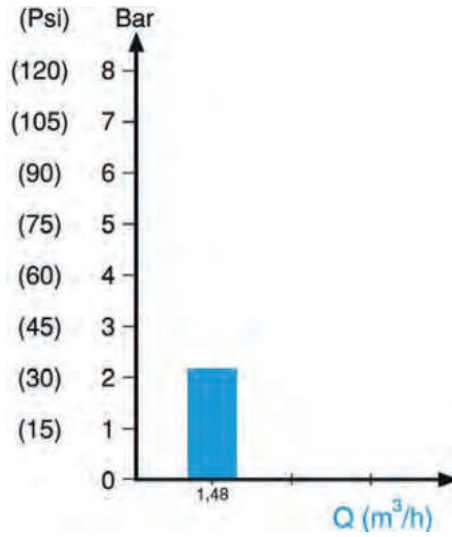

PUMP EXTERNAL DIMENSIONS

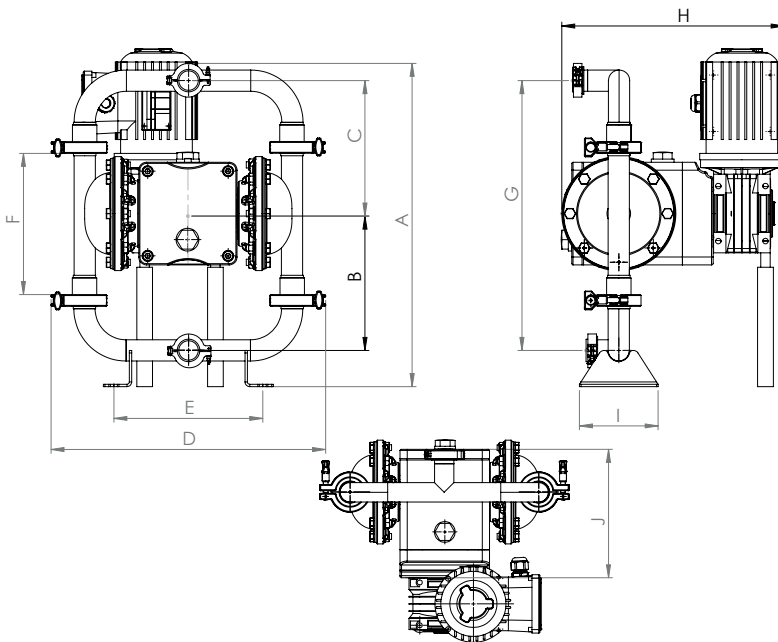

A	B	C	D	E	F	G	H	I	J
412	171	173	350	190	180	344	283	100	180



APPLICATION AREAS

-  MEDICAL INDUSTRY
-  FOOD INDUSTRY
-  PAINT AND COATING INDUSTRY
-  WASTE WATER TREATMENT
-  CHEMICAL INDUSTRY
-  MINING INDUSTRY
-  CERAMIC INDUSTRY
-  RAFINERY

ADVANTAGES

- 1) Solid partaicles may pass through the pump.
- 2) It can work with an electric motor in environments where there is no or insufficient air.
- 3) Maintenance cost is low .
- 4) The flow rate can be controlled by connecting the driver to the electric motor of the pump.
- 5) The suction depth of this pump is 2 m.
- 6) It has the feature of working dry.

PUMP TECHNICAL SPECIFICATIONS

Max. Operating Pressure	: 2 bar
Voltage	: 380/220 volt 50 hz
Energy Consumption	: 0,55 kw
Displacment/Stroke	: 0,55 lt/strok
Max. Discharge Head	: 20 mss
Suction Head	: 2 m
Solid Particle Permeability	: 4 mm
Max. Capacity	: 4 m3/h 66.66 l/min
Reducer Speed	: 60 D/d
Max. Çalışma sıcaklığı	: 100 °C
Inlet	: 1 inch
Outlet	: 1 inch
Body Material	: Sheet Stainless
Diaphragm Options	: Santoprene, Neoprene, Buna-N, EPDM, Teflon, Viton
Ball Options	: Santoprene, Neoprene, Buna-N, EPDM, Teflon, Viton
Ball Seat Options	: Santoprene, Neoprene, Buna-N, EPDM, Teflon, Viton

DIAPHRAGM PUMPS PERFORMANCE CURVES

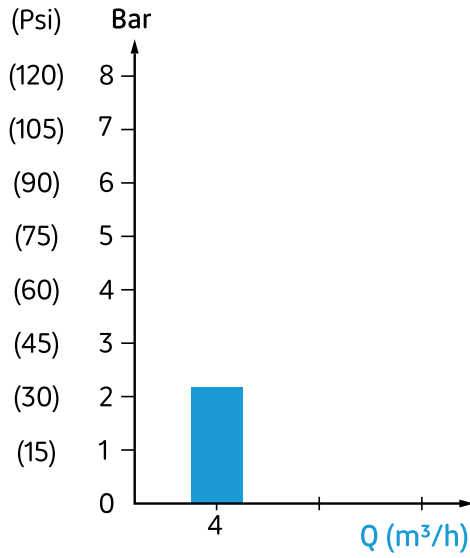

PUMP EXTERNAL DIMENSIONS

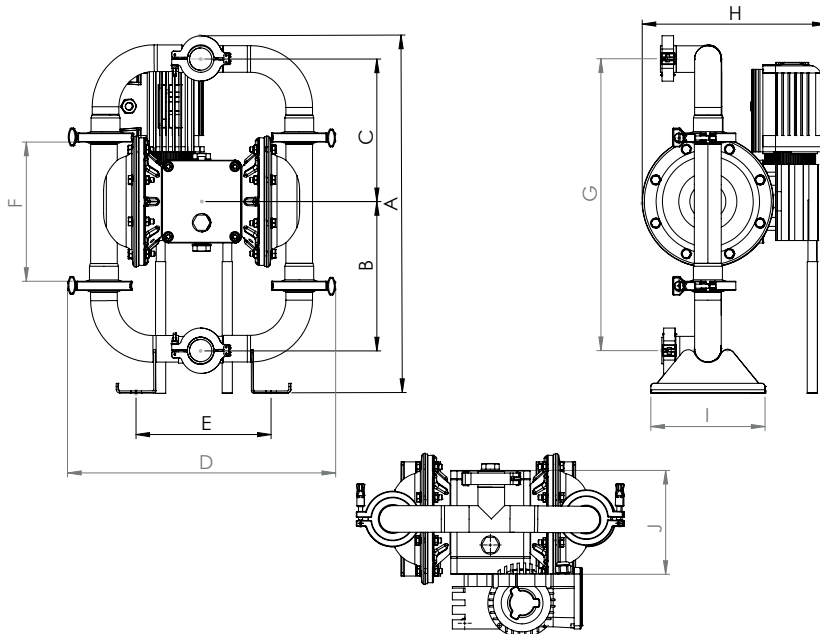

A	B	C	D	E	F	G	H	I	J
565	235	225	423	213	220	460	290	180	164



APPLICATION AREAS

-  MEDICAL INDUSTRY
-  FOOD INDUSTRY
-  PAINT AND COATING INDUSTRY
-  WASTE WATER TREATMENT
-  CHEMICAL INDUSTRY
-  MINING INDUSTRY
-  CERAMIC INDUSTRY
-  RAFINERY

ADVANTAGES

- 1) Solid particles may pass through the pump.
- 2) It can work with an electric motor in environments where there is no or insufficient air.
- 3) Maintenance cost is low .
- 4) The flow rate can be controlled by connecting the driver to the electric motor of the pump.
- 5) The suction depth of this pump is 4 m.
- 6) It has the feature of working dry.

PUMP TECHNICAL SPECIFICATIONS

Max. Operating Pressure	: 4 bar
Voltage	: 380 volt 50 hz
Energy Consumption	: 2,2 kw / 3 kw / 4 kw
Displacement/Stroke	: 1,47 lt/strok
Max. Discharge Head	: 40 mss
Suction Head	: 4 m
Solid Particle Permeability	: 6 mm
Max. Capacity	: 13,8 m ³ /h 230 l/min
Reducer Speed	: 78 D/d
Max. Çalışma sıcaklığı	: 100 °C
Inlet	: 1½ inch
Outlet	: 1½ inch
Body Material	: Sheet Stainless
Diaphragm Options	: Santoprene, Neoprene, Buna-N, EPDM, Teflon, Viton
Ball Options	: Santoprene, Neoprene, Buna-N, EPDM, Teflon, Viton
Ball Seat Options	: Santoprene, Neoprene, Buna-N, EPDM, Teflon, Viton

DIAPHRAGM PUMPS PERFORMANCE CURVES

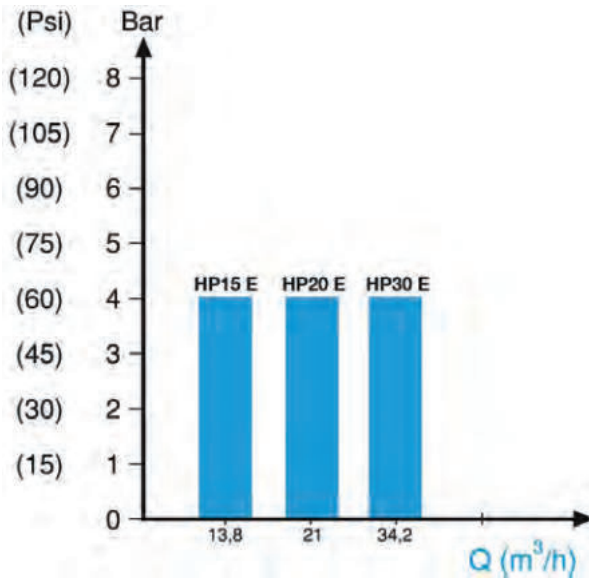

PUMP EXTERNAL DIMENSIONS

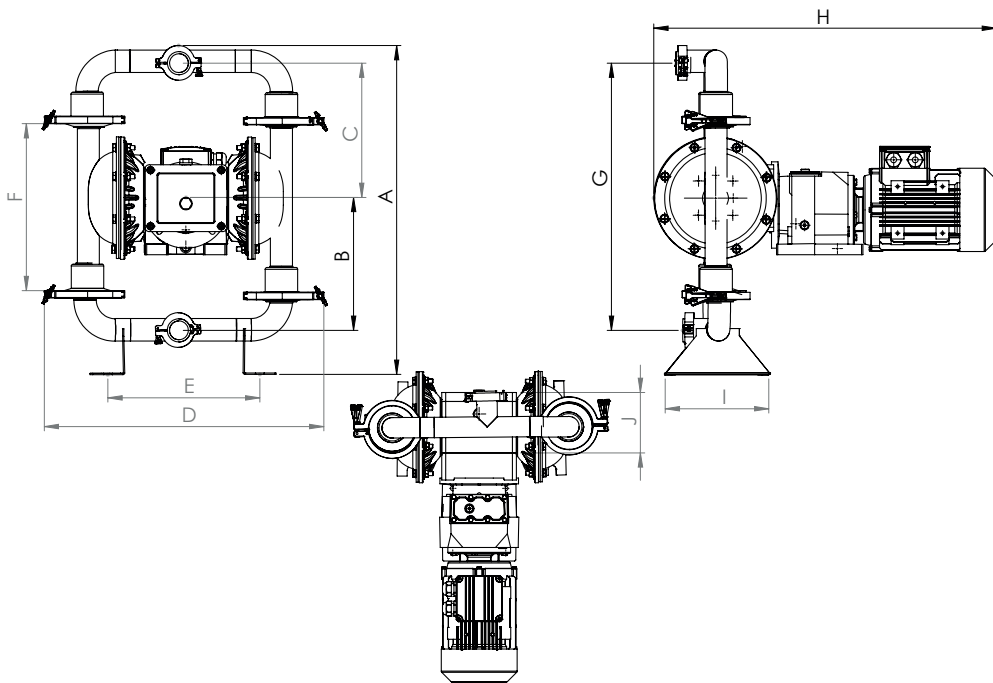

A	B	C	D	E	F	G	H	I	J
762	309	312	648	352	387	620	795	240	154



APPLICATION AREAS

-  MEDICAL INDUSTRY
-  FOOD INDUSTRY
-  PAINT AND COATING INDUSTRY
-  WASTE WATER TREATMENT
-  CHEMICAL INDUSTRY
-  MINING INDUSTRY
-  CERAMIC INDUSTRY
-  RAFINERY

ADVANTAGES

- 1) Solid particles may pass through the pump.
- 2) It can work with an electric motor in environments where there is no or insufficient air.
- 3) Maintenance cost is low .
- 4) The flow rate can be controlled by connecting the driver to the electric motor of the pump.
- 5) The suction depth of this pump is 4 m.
- 6) It has the feature of working dry.

PUMP TECHNICAL SPECIFICATIONS

Max. Operating Pressure	: 4 bar
Voltage	: 380 volt 50 hz
Energy Consumption	: 3kw / 4kw / 5,5 kw
Displacement/Stroke	: 2,24 lt/strok
Max. Discharge Head	: 40 mss
Suction Head	: 4 m
Solid Particle Permeability:	6 mm
Max. Capacity	: 21 m ³ /h 350 l/min
Reducer Speed	: 78 D/d
Max. Çalışma sıcaklığı	: 100 °C
Inlet	: 2 inch
Outlet	: 2 inch
Body Material	: Sheet Stainless
Diaphragm Options	: Santoprene, Neoprene, Buna-N, EPDM, Teflon, Viton
Ball Options	: Santoprene, Neoprene, Buna-N, EPDM, Teflon, Viton
Ball Seat Options	: Santoprene, Neoprene, Buna-N, EPDM, Teflon, Viton

DIAPHRAGM PUMPS PERFORMANCE CURVES

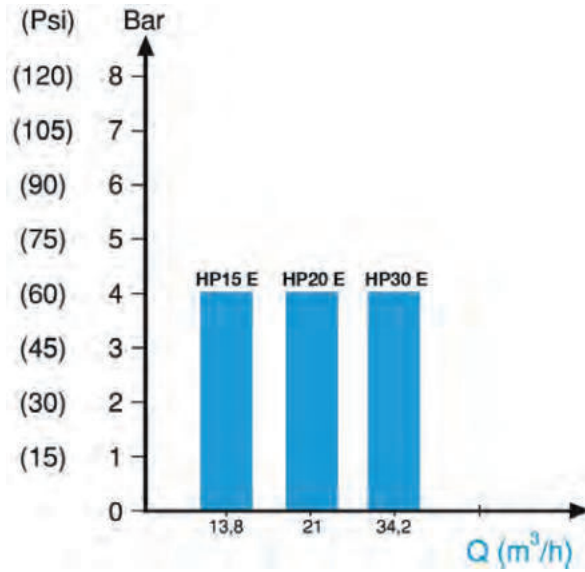

PUMP EXTERNAL DIMENSIONS

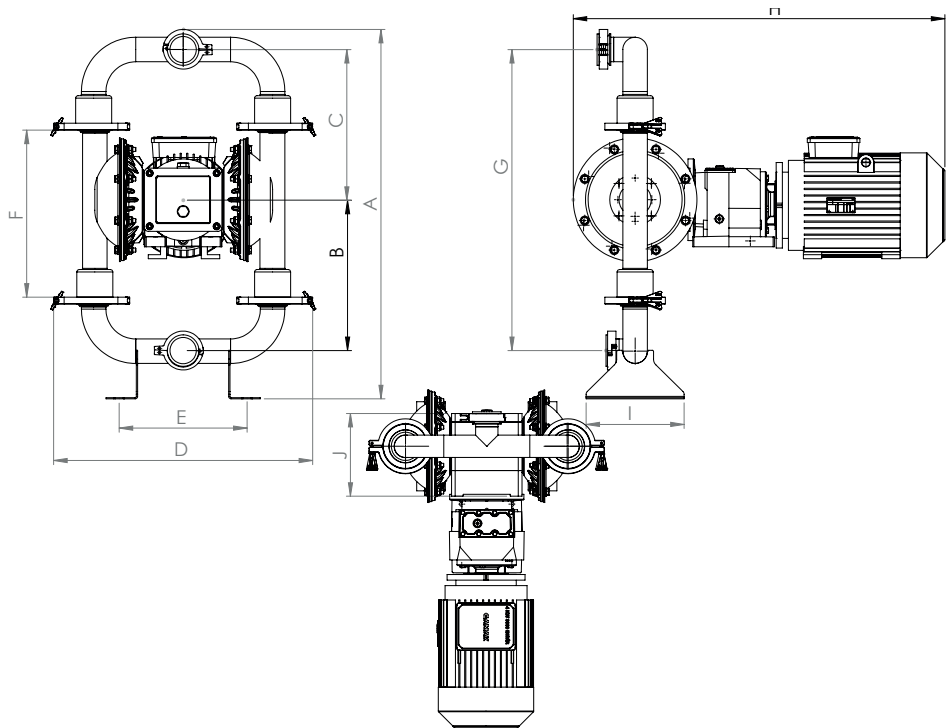

A	B	C	D	E	F	G	H	I	J
905	370	370	635	313	409	738	910	240	223



APPLICATION AREAS

-  MEDICAL INDUSTRY
-  FOOD INDUSTRY
-  PAINT AND COATING INDUSTRY
-  WASTE WATER TREATMENT
-  CHEMICAL INDUSTRY
-  MINING INDUSTRY
-  CERAMIC INDUSTRY
-  RAFINERY

ADVANTAGES

- 1) Solid particles may pass through the pump.
- 2) It can work with an electric motor in environments where there is no or insufficient air.
- 3) Maintenance cost is low .
- 4) The flow rate can be controlled by connecting the driver to the electric motor of the pump.
- 5) The suction depth of this pump is 4 m.
- 6) It has the feature of working dry.

PUMP TECHNICAL SPECIFICATIONS

Max. Operating Pressure	: 4 bar
Voltage	: 380 volt 50 hz
Energy Consumption	: 5,5kw / 7,5 kw
Displacement/Stroke	: 3,65 lt/strok
Max. Discharge Head	: 40 mss
Suction Head	: 4 m
Solid Particle Permeability	: 8 mm
Max. Capacity	: 34,2 m3/h 570 l/min
Reducer Speed	: 78 D/d
Max. Çalışma sıcaklığı	: 100 °C
Inlet	: 3 inch
Outlet	: 3 inch
Body Material	: Sheet Stainless
Diaphragm Options	: Santoprene, Neoprene, Buna-N, EPDM, Teflon, Viton
Ball Options	: Santoprene, Neoprene, Buna-N, EPDM, Teflon, Viton
Ball Seat Options	: Santoprene, Neoprene, Buna-N, EPDM, Teflon, Viton

DIAPHRAGM PUMPS PERFORMANCE CURVES

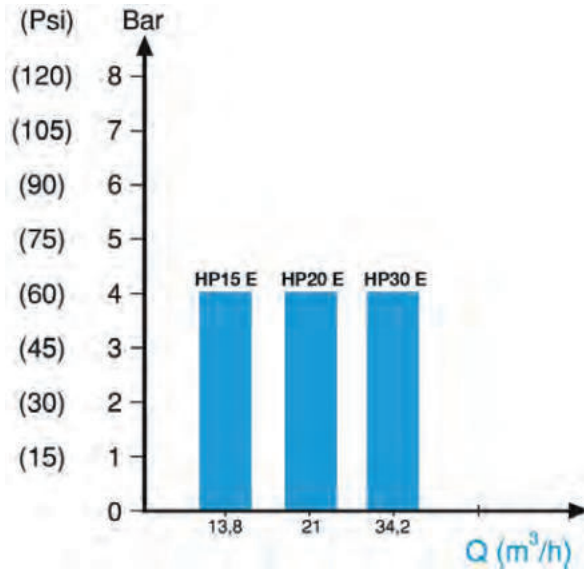

PUMP EXTERNAL DIMENSIONS

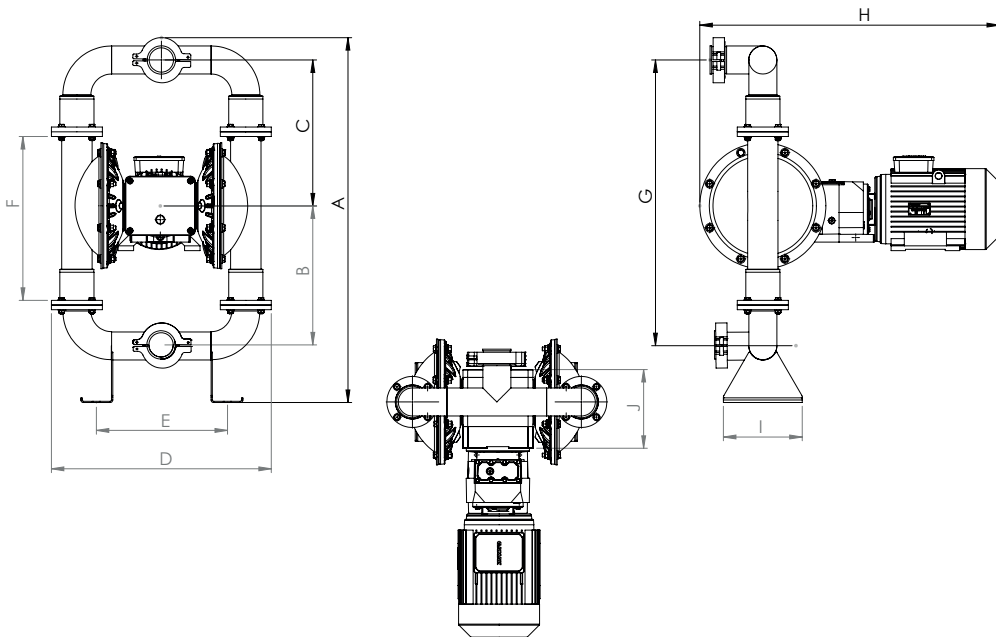

A	B	C	D	E	F	G	H	I	J
1160	442	464	698	416	520	907	950	250	250



APPLICATION AREAS

-  MEDICAL INDUSTRY
-  FOOD INDUSTRY
-  PAINT AND COATING INDUSTRY
-  WASTE WATER TREATMENT
-  CHEMICAL INDUSTRY
-  MINING INDUSTRY
-  CERAMIC INDUSTRY
-  RAFINERY

ADVANTAGES

- 1) Since the pump has a flap, it can pass large solid particles.
- 2) It can work with an electric motor in environments where there is no or insufficient air.
- 3) Maintenance cost is low .
- 4) The flow rate can be controlled by connecting the driver to the electric motor of the pump.
- 5) The suction depth of this pump is 4 m.
- 6) It has the feature of working dry.

PUMP TECHNICAL SPECIFICATIONS

- Max. Operating Pressure** : 4 bar
- Voltage** : 380 volt 50 hz
- Energy Consumption** : 2,2kw / 3kw / 4kw
- Displacment/Stroke** : 1,47 lt/strok
- Max. Discharge Head** : 40 mss
- Suction Head** : 4 m
- Solid Particle Permeability** : 35 mm
- Max. Capacity** : 13,8 m3/h 230 l/min
- Reducer Speed** : 78 D/d
- Max. Çalışma sıcaklığı** : 100 °C
- Inlet** : 1½ inch
- Outlet** : 1½ inch
- Body Material** : Aluminum, Casting, Stainless Steel
- Diaphragm Options** : Santoprene, Neoprene, Buna-N, EPDM, Teflon, Viton
- Ball Options** : Santoprene, Neoprene, Buna-N, EPDM, Teflon, Viton
- Ball Seat Options** : Santoprene, Neoprene, Buna-N, EPDM, Teflon, Viton

DIAPHRAGM PUMPS PERFORMANCE CURVES

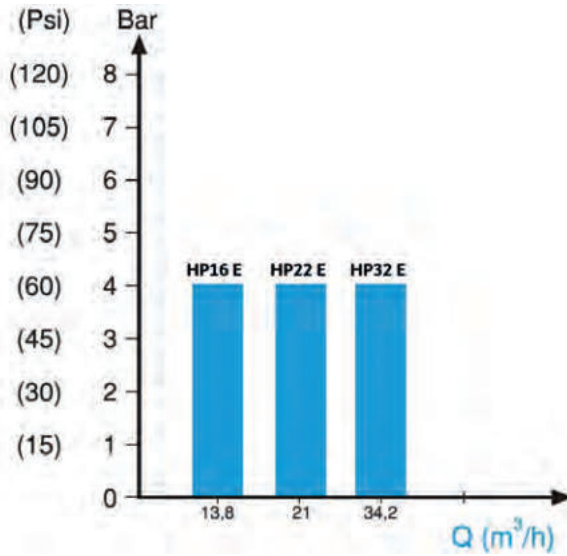

PUMP EXTERNAL DIMENSIONS

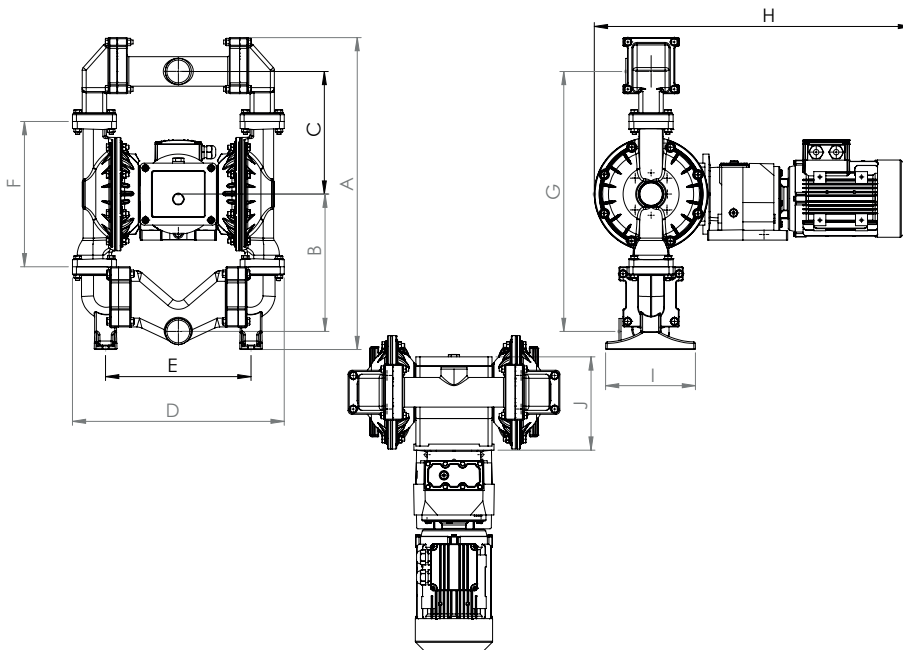

A	B	C	D	E	F	G	H	I	J
780	345	306	530	365	363	650	792	225	233



APPLICATION AREAS

-  MEDICAL INDUSTRY
-  FOOD INDUSTRY
-  PAINT AND COATING INDUSTRY
-  WASTE WATER TREATMENT
-  CHEMICAL INDUSTRY
-  MINING INDUSTRY
-  CERAMIC INDUSTRY
-  RAFINERY

ADVANTAGES

- 1) Since the pump has a flap, it can pass large solid particles.
- 2) It can work with an electric motor in environments where there is no or insufficient air.
- 3) Maintenance cost is low .
- 4) The flow rate can be controlled by connecting the driver to the electric motor of the pump.
- 5) The suction depth of this pump is 4 m.
- 6) It has the feature of working dry.

PUMP TECHNICAL SPECIFICATIONS

Max. Operating Pressure	: 4 bar
Voltage	: 380 volt 50 hz
Energy Consumption	: 3 kw / 4 kw / 5,5 kw
Displacment/Stroke	: 2,24 lt/strok
Max. Discharge Head	: 40 mss
Suction Head	: 4 m
Solid Particle Permeability	: 6 mm
Max. Capacity	: 21 m ³ /h 350 l/min
Reducer Speed	: 78 D/d
Max. Çalışma Sıcaklığı	: 100 °C
Inlet	: 2 inch
Outlet	: 2 inch
Body Material	: Aluminum, Casting, Stainless Steel
Diaphragm Options	: Santoprene, Neoprene, Buna-N, EPDM, Teflon, Viton
Ball Options	: Santoprene, Neoprene, Buna-N, EPDM, Teflon, Viton
Ball Seat Options	: Santoprene, Neoprene, Buna-N, EPDM, Teflon, Viton

DIAPHRAGM PUMPS PERFORMANCE CURVES

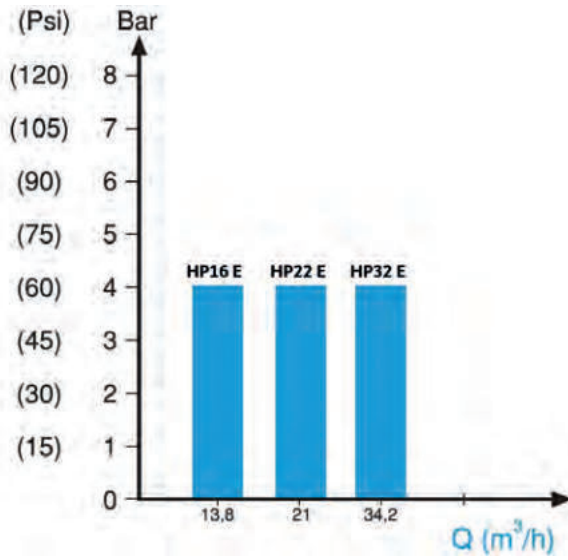

PUMP EXTERNAL DIMENSIONS

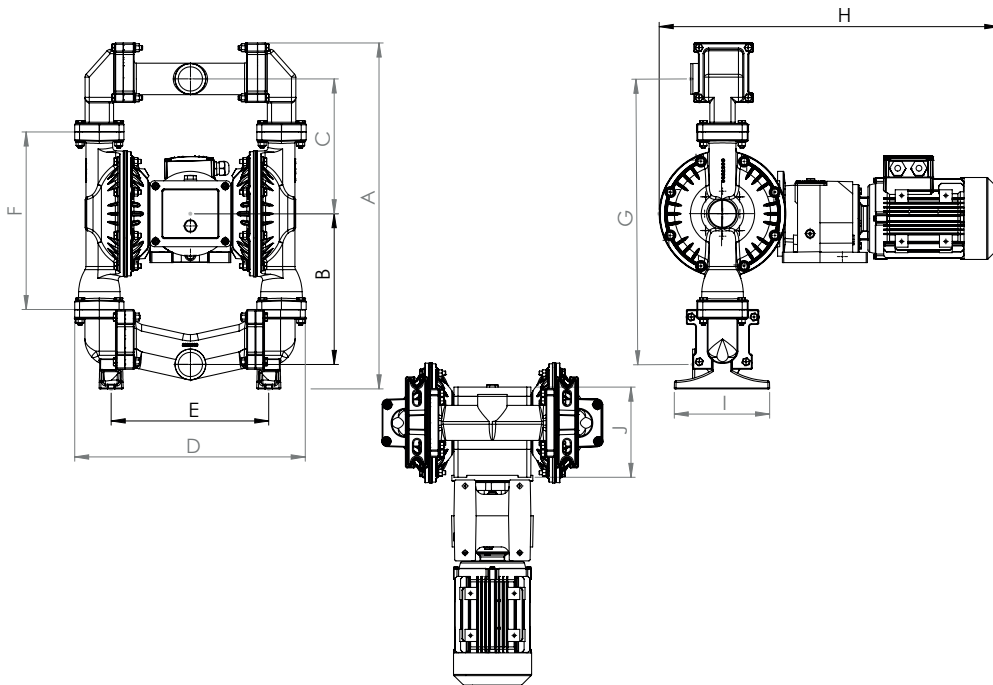

A	B	C	D	E	F	G	H	I	J
815	355	318	543	371	418	673	800	225	223



APPLICATION AREAS

-  MEDICAL INDUSTRY
-  FOOD INDUSTRY
-  PAINT AND COATING INDUSTRY
-  WASTE WATER TREATMENT
-  CHEMICAL INDUSTRY
-  MINING INDUSTRY
-  CERAMIC INDUSTRY
-  RAFINERY

ADVANTAGES

- 1) Since the pump has a flap, it can pass large solid particles.
- 2) It can work with an electric motor in environments where there is no or insufficient air.
- 3) Maintenance cost is low .
- 4) The flow rate can be controlled by connecting the driver to the electric motor of the pump.
- 5) The suction depth of this pump is 4 m.
- 6) It has the feature of working dry.

PUMP TECHNICAL SPECIFICATIONS

Max. Operating Pressure	: 4 bar
Voltage	: 380 volt 50 hz
Energy Consumption	: 5,5 kw / 7,5 kw
Displacment/Stroke	: 3,65 lt/strok
Max. Discharge Head	: 40 mss
Suction Head	: 4 m
Solid Particle Permeability	: 8 mm
Max. Capacity	: 34,2 m3/h 570 l/min
Reducer Speed	: 78 D/d
Max. Çalışma sıcaklığı	: 100 °C
Inlet	: 3 inch
Outlet	: 3 inch
Body Material	: Aluminum, Casting, Stainless Steel
Diaphragm Options	: Santoprene, Neoprene, Buna-N, EPDM, Teflon, Viton
Ball Options	: Santoprene, Neoprene, Buna-N, EPDM, Teflon, Viton
Ball Seat Options	: Santoprene, Neoprene, Buna-N, EPDM, Teflon, Viton

DIAPHRAGM PUMPS PERFORMANCE CURVES

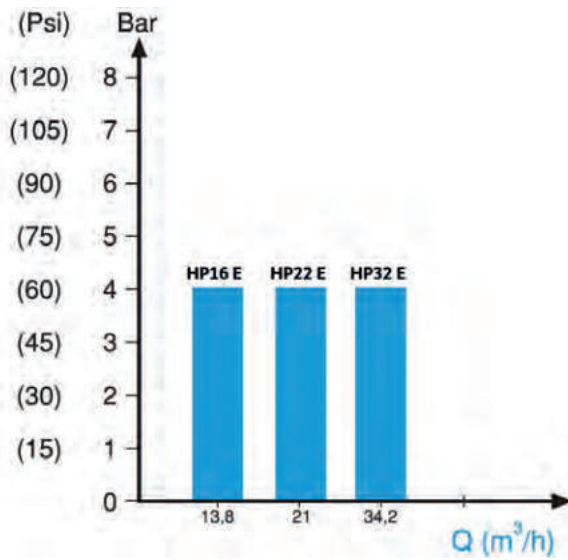

PUMP EXTERNAL DIMENSIONS

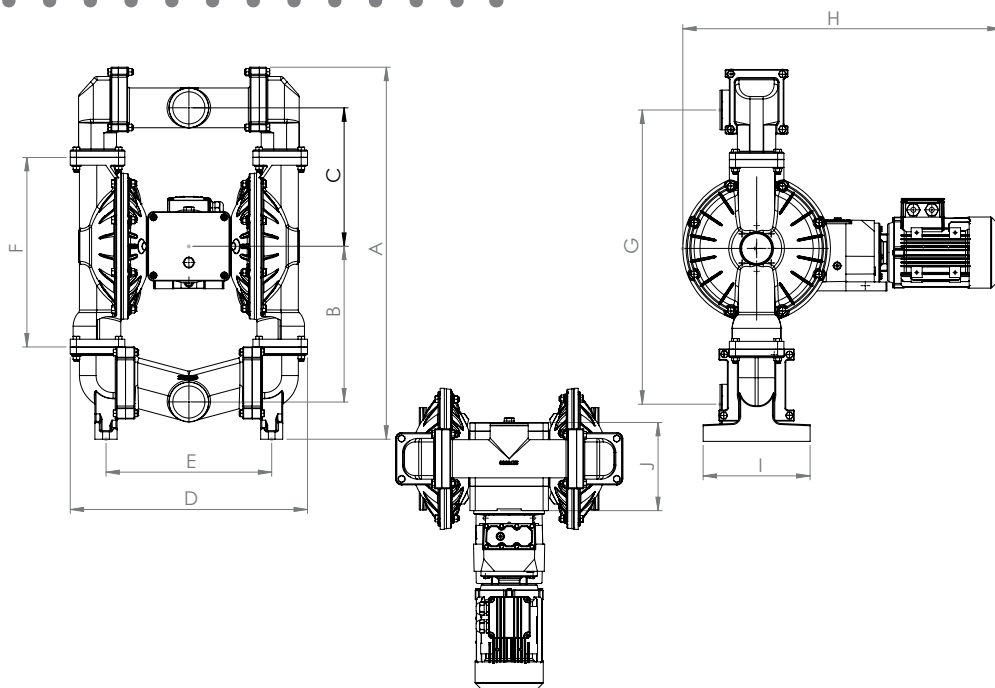

A	B	C	D	E	F	G	H	I	J
1009	423	376	645	450	514	800	865	290	250



APPLICATION AREAS

- WASTE WATER TREATMENT
- TEXTILE
- PACKAGING
- AUTOMOTIVE
- FOOD INDUSTRY
- PAINT INDUSTRY
- MINING - ENERGY
- MARINE
- MACHINE-AUTOMATION
- DEFENSE INDUSTRY
- PETROL AND OIL
- CERAMIC INDUSTRY
- MEDICAL INDUSTRY

ADVANTAGES

- 1) Solid particles may pass through the pump.
- 2) The pump is ex-proof. (Suitable for explosive and flammable fluids.)
- 3) Maintenance cost is low.
- 4) Liquid flow rate can also be adjusted when the air inlet pressure of the pump is adjusted.
- 5) The pump's air valve and pilot valve repair kits can be repaired without disassembling the pump.
- 6) It has the feature of working dry.
- 7) The suction depth of this pump is 6 m.

PUMP TECHNICAL SPECIFICATIONS

- Max. Capacity** : 400 l/min
- Fluid Inlet-Outlet** : 1½ inch
- Max. Fluid Discharge** : 7 bar
- Body Material** : Aluminum, Casting, Stainless Steel
- Air Inlet Size** : 3/4 inch
- Solid Particle Size** : 35 mm
- Suction Head** : 6 m
- Max Air Pressure** : 7 bar
- Diaphragm Options** : Santoprene, Neoprene, Buna-N, EPDM, Teflon, Viton
- Ball Options** : Santoprene, Neoprene, Buna-N, EPDM, Teflon, Viton
- Ball Seat Options** : Santoprene, Neoprene, Buna-N, EPDM, Teflon, Viton

DIAPHRAGM PUMPS PERFORMANCE CURVES

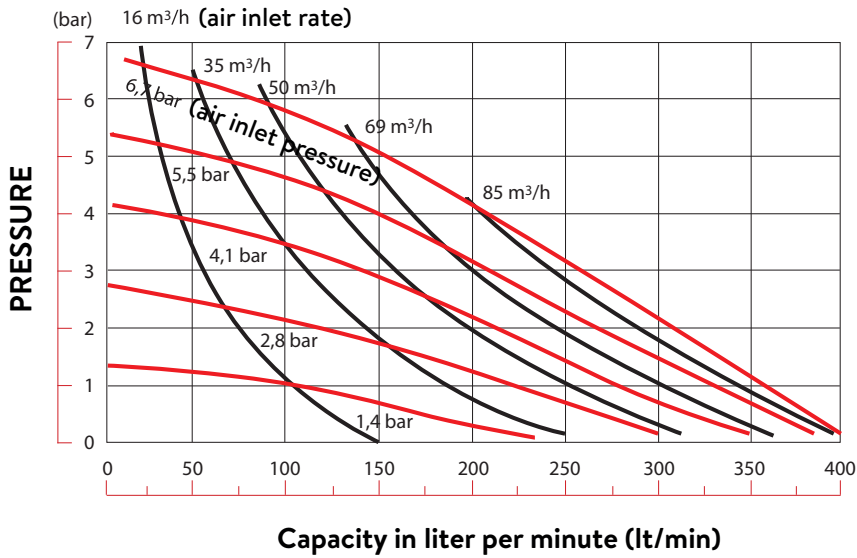

PUMP EXTERNAL DIMENSIONS

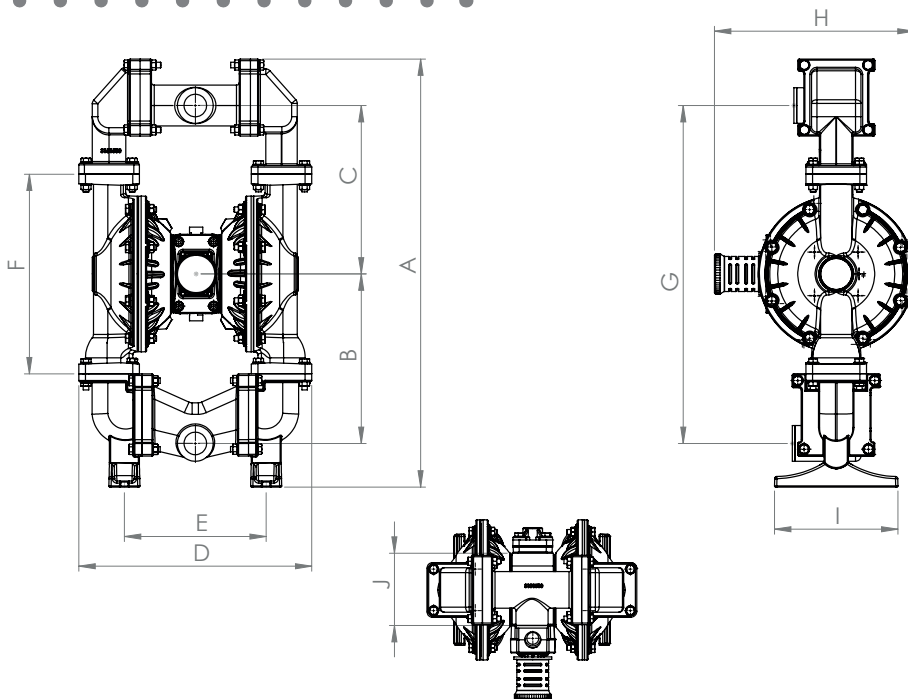

A	B	C	D	E	F	G	H	I	J
780	309	307	424	258	364	615	365	225	147



APPLICATION AREAS



- | | |
|---|--|
|  WASTE WATER TREATMENT |  MARINE |
|  TEXTILE |  MACHINE-AUTOMATION |
|  PACKAGING |  DEFENSE INDUSTRY |
|  AUTOMOTIVE |  PETROL AND OIL |
|  FOOD INDUSTRY |  CERAMIC INDUSTRY |
|  PAINT INDUSTRY |  MEDICAL INDUSTRY |
|  MINING - ENERGY | |

ADVANTAGES



- 1) Solid particles may pass through the pump.
- 2) The pump is ex-proof. (Suitable for explosive and flammable fluids.)
- 3) Maintenance cost is low.
- 4) Liquid flow rate can also be adjusted when the air inlet pressure of the pump is adjusted.
- 5) The pump's air valve and pilot valve repair kits can be repaired without disassembling the pump.
- 6) It has the feature of working dry.
- 7) The suction depth of this pump is 6 m.

PUMP TECHNICAL SPECIFICATIONS



- | | |
|-----------------------------|---|
| Max. Capacity | : 560 l/min |
| Fluid Inlet-Outlet | : 2 inch |
| Max. Fluid Discharge | : 7 bar |
| Body Material | : Aluminum, Casting, Stainless Steel |
| Air Inlet Size | : 3/4 inch |
| Solid Particle Size | : 45 mm |
| Suction Head | : 6 m |
| Max Air Pressure | : 7 bar |
| Diaphragm Options | : Santoprene, Neoprene, Buna-N, EPDM, Teflon, Viton |
| Ball Options | : Santoprene, Neoprene, Buna-N, EPDM, Teflon, Viton |
| Ball Seat Options | : Santoprene, Neoprene, Buna-N, EPDM, Teflon, Viton |

DIAPHRAGM PUMPS PERFORMANCE CURVES

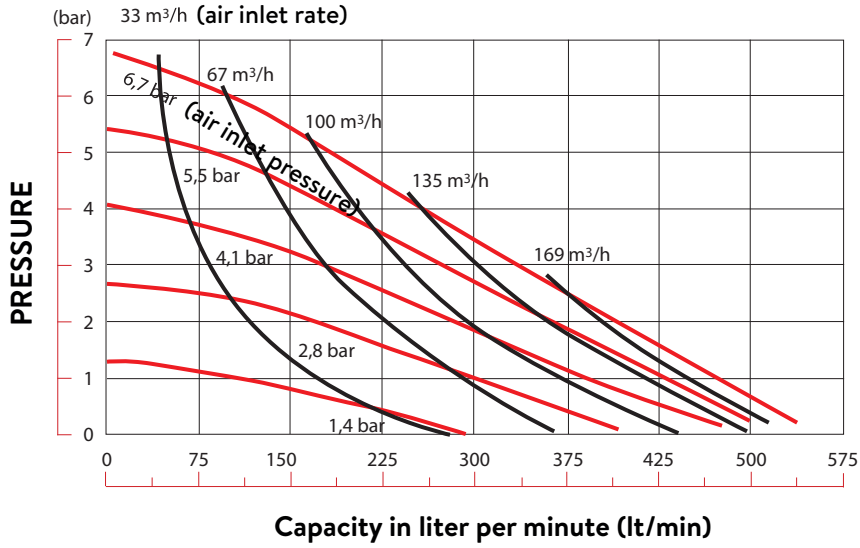

PUMP EXTERNAL DIMENSIONS

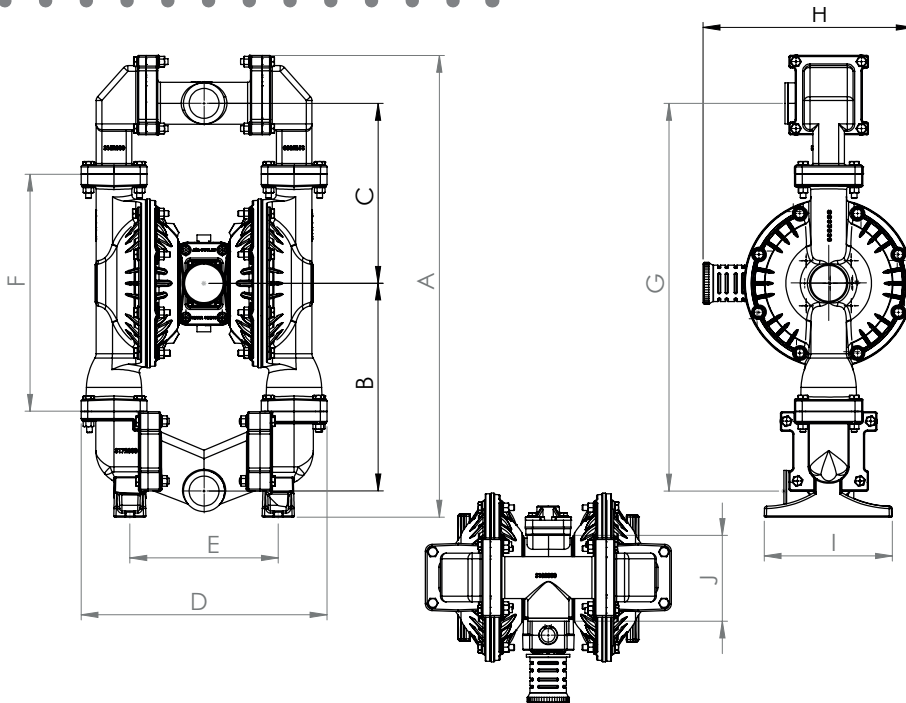

A	B	C	D	E	F	G	H	I	J
815	367	318	434	262	418	685	370	226	152



APPLICATION AREAS



- | | |
|---|--|
|  WASTE WATER TREATMENT |  MARINE |
|  TEXTILE |  MACHINE-AUTOMATION |
|  PACKAGING |  DEFENSE INDUSTRY |
|  AUTOMOTIVE |  PETROL AND OIL |
|  FOOD INDUSTRY |  CERAMIC INDUSTRY |
|  PAINT INDUSTRY |  MEDICAL INDUSTRY |
|  MINING - ENERGY | |

ADVANTAGES



- 1) Solid particles may pass through the pump.
- 2) The pump is ex-proof. (Suitable for explosive and flammable fluids.)
- 3) Maintenance cost is low.
- 4) Liquid flow rate can also be adjusted when the air inlet pressure of the pump is adjusted.
- 5) The pump's air valve and pilot valve repair kits can be repaired without disassembling the pump.
- 6) It has the feature of working dry.
- 7) The suction depth of this pump is 6 m.

PUMP TECHNICAL SPECIFICATIONS



- | | |
|-----------------------------|---|
| Max. Capacity | : 890 l/min |
| Fluid Inlet-Outlet | : 3 inch |
| Max. Fluid Discharge | : 7 bar |
| Body Material | : Aluminum, Casting, Stainless Steel |
| Air Inlet Size | : 3/4 inch |
| Solid Particle Size | : 75 mm |
| Suction Head | : 6 m |
| Max Air Pressure | : 7 bar |
| Diaphragm Options | : Santoprene, Neoprene, Buna-N, EPDM, Teflon, Viton |
| Ball Options | : Santoprene, Neoprene, Buna-N, EPDM, Teflon, Viton |
| Ball Seat Options | : Santoprene, Neoprene, Buna-N, EPDM, Teflon, Viton |

DIAPHRAGM PUMPS PERFORMANCE CURVES

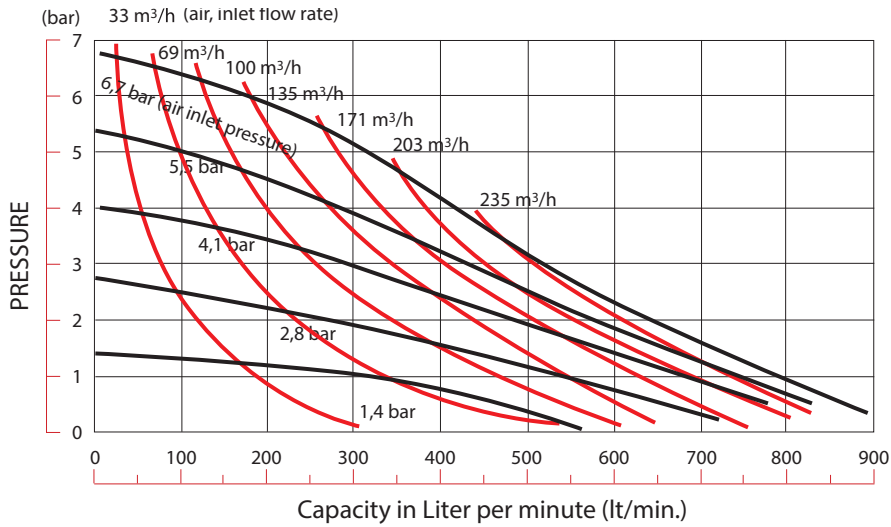

PUMP EXTERNAL DIMENSIONS

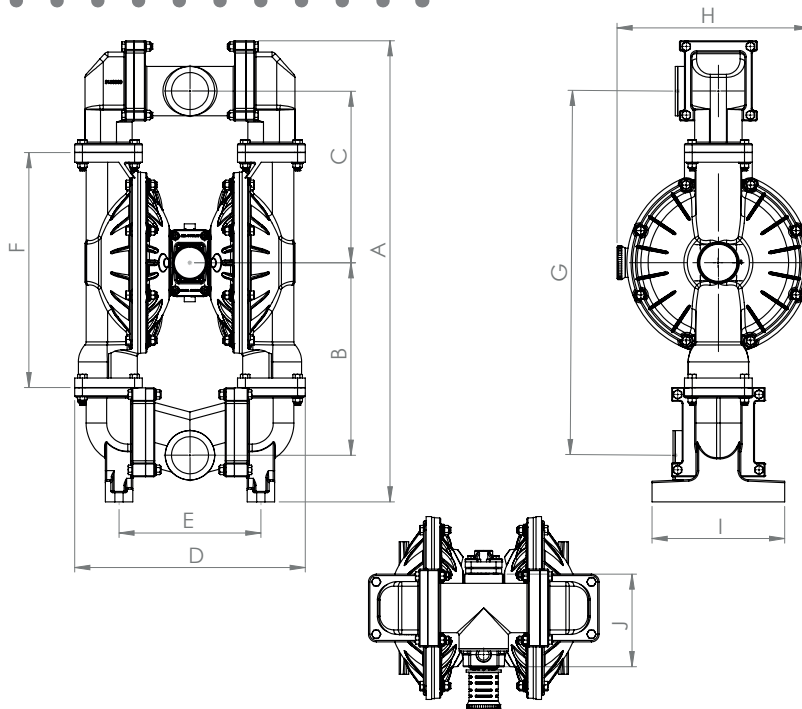

A	B	C	D	E	F	G	H	I	J
1009	421	376	505	310	514	797	422	290	203

VESTAPOMP
M a k e s l i f e c o m f o r t a b l e

www.vestapump.com

Hukukçular Towers Cevizli Mh. Mustafa Kemal Cd. No:66 A Blok Kat:1, 34865 - Kartal / İstanbul / TÜRKİYE
[+90] 216 389 56 57 - vesta@vestapump.com